

Category Theory in Context

Answer Key

Anthony Agwu	Jay Chernak	Bruce James
Matthew Kousoulas	Mark Laczin	Amarit Matharu
Emily McGovern	Keith Pardue	Teddy Weinberg

Autumn, 2018

Contents

Chapter 1

Categories, Functors, Natural Transformations

1.1 Abstract and concrete categories

EXERCISE 1.1.i.

- (i) Show that a morphism can have at most one inverse isomorphism.

PROOF. Let $f: x \rightarrow y$ be an arbitrary morphism, and let $g: y \rightarrow x$ and $h: y \rightarrow x$ be two inverse isomorphisms of f . That is to say, $gf = hf = 1_x$ and $fg = fh = 1_y$. Consider the composition gfh . This is a valid composition, since the domain of g is equal to the codomain of f , and the domain of f is equal to the codomain of h . Composition is associative, so $(gf)h = g(fh)$.

Evaluate each of these expressions independently:

- Evaluated as $(gf)h$, we find that $gf = 1_x$, so $(gf)h = 1_x h = h$.
- Evaluated as $g(fh)$, we find that $fh = 1_y$, so $g(fh) = g1_y = g$.

Since both expressions are equal, we can conclude that $h = g$. So any two inverse isomorphisms of f must be equal. Since f was arbitrary, we can generalize to conclude that any morphism can have at most one (distinct) inverse isomorphism. \square

- (ii) Consider a morphism $f: x \rightarrow y$. Show that if there exist a pair of isomorphisms $g, h: y \rightarrow x$ so that $gf = 1_x$ and $fh = 1_y$, then $g = h$ and f is an isomorphism.

PROOF. Let $f: x \rightarrow y$ be an arbitrary morphism, and let $g, h: y \rightarrow x$ be morphisms such that $gf = 1_x$ and $fh = 1_y$. Similarly to above, evaluate the composition gfh as $(gf)h = 1_x h = h$ and as $g(fh) = g1_y = g$. Due to associativity, we have $(gf)h = g(fh)$. So we can conclude that $g = h$. Since $fh = 1_y$ was given, using our previous conclusion, we can substitute g for h to obtain $fg = 1_y$. Since we were also given $gf = 1_x$, we can conclude that f is an isomorphism. \square

DEFINITION 1.1.11. A **groupoid** is a category in which every morphism is an isomorphism.

EXERCISE 1.1.ii. Let \mathbf{C} be a category. Show that the collection of isomorphisms in \mathbf{C} defines a subcategory, the **maximal groupoid** inside \mathbf{C} .

PROOF. Let \mathbf{C}_{iso} denote the objects of \mathbf{C} together with its isomorphisms. We wish to show that \mathbf{C}_{iso} is a category. \mathbf{C}_{iso} inherits composition and associativity from \mathbf{C} . Notice that the identity morphism for each object in \mathbf{C} is clearly an isomorphism as it is both right and left invertible, so the identity morphisms for each object are in \mathbf{C}_{iso} . Because composition in \mathbf{C}_{iso} is the same as in \mathbf{C} , each object will have the same identity morphism as in \mathbf{C} . To show \mathbf{C}_{iso} is closed under composition, take two morphisms $f: x \rightarrow y$ and $g: u \rightarrow x$ in \mathbf{C}_{iso} . Since f is an isomorphism, then there is a morphism $h \in \text{mor } \mathbf{C}_{\text{iso}}$ with $h: y \rightarrow x$, such that $fh = 1_y$ and $hf = 1_x$. Likewise, since g is an isomorphism, then there is a morphism $j \in \text{mor } \mathbf{C}_{\text{iso}}$ with $j: x \rightarrow u$, such that $gj = 1_x$ and $fg = 1_u$. We can take the composition fg , since $\text{dom}(f) = \text{cod}(g)$. We also have the composition jh , since $\text{dom}(j) = \text{cod}(h)$. And again, respecting domains and codomains, we have the composition $(fg)(jh)$, since $\text{dom}(fg) = \text{cod}(jh)$. From the associativity of the parent category \mathbf{C} , then $(fg)(jh) = f(gj)h = f(1_x)h = fh = 1_y$. Thus jh is the right inverse of the composition fg . Similarly, since $\text{cod}(fg) = \text{dom}(jh)$, we have the composition $(jh)(fg)$, which again from the associativity of the category \mathbf{C} , $(jh)(fg) = j(hf)g = j1_xg = jg = 1_u$. So, jh is the left inverse of fg , and fg is an isomorphism.

We have shown that \mathbf{C}_{iso} is a category, with all of the objects of \mathbf{C} and morphisms of \mathbf{C} restricted to the isomorphisms of \mathbf{C} . So the groupoid \mathbf{C}_{iso} is a subcategory of \mathbf{C} . Presented with any other subcategory \mathbf{D} , of \mathbf{C} , that is strictly larger than \mathbf{C}_{iso} , there must be a morphism in \mathbf{D} that is not in \mathbf{C}_{iso} . Then this morphism must not be an isomorphism, and hence, \mathbf{D} cannot be a groupoid. So, the category \mathbf{C}_{iso} is the maximal groupoid that is a subcategory of \mathbf{C} . \square

EXERCISE 1.1.iii. For any category \mathbf{C} and any object c in \mathbf{C} show that:

1. There is a category \mathbf{C}/c whose objects are morphisms $f: c \rightarrow x$ with domain c and in which a morphism from $f: c \rightarrow x$ to $g: c \rightarrow y$ is a map $h: x \rightarrow y$ between the codomains so that the triangle

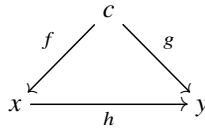

commutes, i.e., so that $g = hf$.

2. There is a category \mathbf{C}/c whose objects are morphisms $f: x \rightarrow c$ with codomain c and in which a morphism from $f: x \rightarrow c$ to $g: y \rightarrow c$ between the domains so that

the triangle

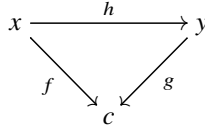

commutes, i.e., so that $f = gh$

The categories c/\mathbf{C} and \mathbf{C}/c are called **slice categories** of \mathbf{C} **under** and **over** c , respectively.

PROOF. First we must determine the form of the objects and morphisms in c/\mathbf{C} . The objects of c/\mathbf{C} are diagrams of the following form.

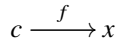

The morphisms in c/\mathbf{C} are diagrams of the following form.

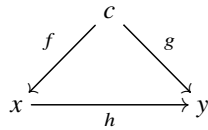

Though this notation is by no means standard, to help distinguish between morphisms in \mathbf{C} and morphisms in the slice categories, we will define h' as a short hand for the diagram with the morphism h as the bottom arrow (or top in \mathbf{C}/c). Notice that both the objects are commutative diagrams in \mathbf{C} . We could also think of the objects as functors¹ from the category $\mathbb{2}$ and the morphisms as functors from the category $\mathbb{3}$. By the way we have defined morphisms the only reasonable choices for the domain and codomain of h' are f and g respectively.

We can see how to compose two compatible morphisms $i': e \rightarrow f$ and $h': f \rightarrow g$ in c/\mathbf{C} by looking at the following diagram in \mathbf{C} .

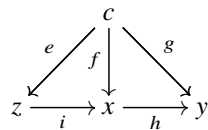

Since $(hi)e = h(ie) = hf = g$ in \mathbf{C} the diagram commutes, and the composition hi can be thought of as a member of c/\mathbf{C} denoted as $(hi)'$ with domain and codomain e and g , respectively. Using the diagram notation $(hi)'$ is denoted as follows.

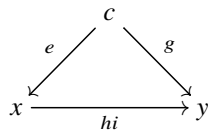

¹Functors are defined in section 1.3. Right now the diagrams here are just helpful tools to keep track of equations. Diagrams are made formal in section 1.6.

Because we have defined composition in c/C in terms of composition in C , c/C inherits the associativity of C . That is for composable morphisms h' , i' , and j' in C we have

$$(h'i')j' = (hi)j = h(ij) = h'(i'j').$$

We need to obtain the identity morphism of each object f in c/C . To do so notice that the follow diagram commutes, because C is a category.

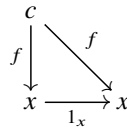

Looking at the same diagram from a different perspective we see that 1_x actually acts as the identity morphism for f in c/C . Since we were careful when defining the morphisms in c/C , this identity is well defined. If we had defined the morphisms in c/C to be anything less than a commutative diagrams, it would seem as $1'_x$ could serve as the identity for multiple objects in c/C . This issue is not restricted to identity morphisms, but this ambiguity is most obvious in the case of identity morphisms. However, since we defined morphisms appropriately, we can use the notation defined earlier to write $1'_x = 1_f : f \rightarrow f$ without any ambiguity. This notion can be used to obtain the left and right identities by considering the following commutative diagram in C

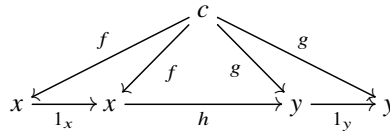

Translating the above diagram into the slice category notation we have that $h'1_f = h' = 1_g h'$. We have shown that c/C satisfies all the axioms of a category.

We can use the same procedure to show that C/c is also a category. The only difference is direction of each arrow. Hence this proof will be relatively terse. The objects in c/C are the following diagram.

$$x \xrightarrow{f} c$$

A morphisms h' in C/c has the form of the following diagram.

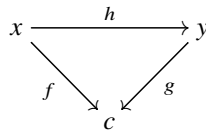

The domain of h' is f and the codomain of h is g . We define composition on C/c by taking compatible in C/c morphisms $i' : e \rightarrow f$ and $h' : f \rightarrow g$ and observing the following diagram in C .

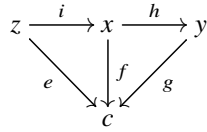

Again this diagram commutes since $g(hi) = (gh)i = fi = e$ in \mathbf{C} . We see that (ih) is member of \mathbf{C}/c with domain e and codomain g and is denoted as follows.

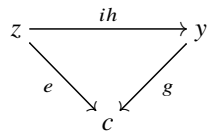

Just like we did in the previous case, we have defined composition in terms of the composition in \mathbf{C} . Hence the associativity is inherited. That is given composable morphisms i', h' , and j' we have

$$(j'h')i' = (jh)i = j(hi) = j'(h'i').$$

We can obtain the identity element for each object f in \mathbf{C}/c in the exact same way as before.

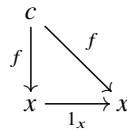

Since the above diagram commutes we can write $1'_x = 1_f : f \rightarrow f$. To get an identity for an arbitrary element observe that the diagram below commutes and gives us that $1_f h' = h' = h' 1_g$.

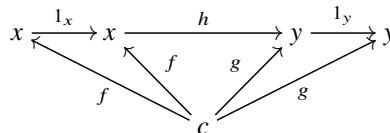

Therefore both c/\mathbf{C} and \mathbf{C}/c are categories in their own right. □

If you looked over to the next page and read the definition of opposite categories, you should notice that $((c/(\mathbf{C}^{\text{op}}))^{\text{op}} = (\mathbf{C}/c)$. If we knew about opposite categories beforehand we could have just proved that the c/\mathbf{C} is a category and then cited this result and been done (since the opposite category is category, it's in the name after all), without all the extra tedium of swapping arrows.

1.2 Duality

EXERCISE 1.2.i. Show that $\mathbf{C}/c \cong (c/(\mathbf{C}^{\text{op}}))^{\text{op}}$. Defining \mathbf{C}/c to be $(c/(\mathbf{C}^{\text{op}}))^{\text{op}}$, deduce Exercise 1.1.iii(ii) from Exercise 1.1.iii(i).

PROOF. This exercise asks us to prove that two categories are isomorphic, which is a notion that we have not yet encountered. But, I will prove that the two categories are equal!

This exercise uses definitions from Exercise 1.1.iii. There are so many layers in the present exercise that to keep things straight, it will help to add one more piece of notation. Recall that for an object c of a category \mathbf{C} , the slice category \mathbf{C}/c of \mathbf{C} over c has as objects the morphisms $f: x \rightarrow c$ in \mathbf{C} . A morphism from f to g in \mathbf{C}/c , where f has domain x and g domain y in \mathbf{C} , is a morphism $h: x \rightarrow y$ in \mathbf{C} such that $gh = f$. To distinguish between h as viewed in \mathbf{C} and in \mathbf{C}/c , let's write $h': f \rightarrow g$ when we want to consider h as a morphism in \mathbf{C}/c and $h: x \rightarrow y$ when we want to consider it in \mathbf{C}^2 . We can use similar notation for the slice category c/\mathbf{C} of \mathbf{C} under c .

Since we will make systematic and careful use of opposite categories, recall that the objects and morphisms of \mathbf{C} and of \mathbf{C}^{op} are *precisely the same*. Only, the assignment of domains and codomains are swapped, allowing order of composition to be swapped. If f is a morphism in \mathbf{C} , then f^{op} is precisely the same morphism, but the op reminds us that we are considering it in \mathbf{C}^{op} rather than in \mathbf{C} so that we have different assignments for domain and codomain.

Now, I claim that $\mathbf{C}/c = (c/(\mathbf{C}^{\text{op}}))^{\text{op}}$. We must first check that they have the same objects, though we notate f in the first category as f^{op} in the second. Then, for every pair of objects f and g in \mathbf{C}/c we must see that

$$(\mathbf{C}/c)(f, g) = (c/(\mathbf{C}^{\text{op}}))^{\text{op}}(f^{\text{op}}, g^{\text{op}}).$$

(Note that we use this notation even when \mathbf{C} is not locally small, so that each side of the equality might be a proper class.) Finally, we must see that composition of morphisms is the same in each category.

Since the objects of a category and its opposite category are the same, the objects in $(c/(\mathbf{C}^{\text{op}}))^{\text{op}}$ are the objects in $c/(\mathbf{C}^{\text{op}})$, which are morphisms $f^{\text{op}}: c \rightarrow x$ in \mathbf{C}^{op} . But, these are the same as morphisms $f: x \rightarrow c$ in \mathbf{C} , which is to say objects of \mathbf{C}/c as claimed.

For the rest, let $f: x \rightarrow c$, $g: y \rightarrow c$ and $h: z \rightarrow c$ be three morphisms in \mathbf{C} . A morphism

$$i^{\text{op}'\text{op}}: f^{\text{op}} \rightarrow g^{\text{op}}$$

in $(c/(\mathbf{C}^{\text{op}}))^{\text{op}}$ is just a morphism

$$i^{\text{op}'}: g^{\text{op}} \rightarrow f^{\text{op}}$$

²The notation h' can still be ambiguous since there might also be other $i: c \rightarrow x$ and $j: c \rightarrow y$ such that $jh = i$ so that we also have $h': i \rightarrow j$. This leads to different morphisms labeled h' , but they are distinguished by their domains and codomains

in $c/(\mathbf{C}^{\text{op}})$. This in turn is a morphism $i^{\text{op}}: y \rightarrow x$ such that $i^{\text{op}}g^{\text{op}} = f^{\text{op}}$ in \mathbf{C}^{op} , together with the ordered pair $(g^{\text{op}}, f^{\text{op}})$ giving the domain and codomain of i^{op} . Unravelling one more layer, this is in turn a morphism $i: x \rightarrow y$ such that $gi = f$ in \mathbf{C} together with the ordered pair (f, g) . This in turn corresponds to a morphism $i': f \rightarrow g$ in \mathbf{C}/c . Each of these correspondences is actually an equality of classes. So, we have argued that

$$\begin{aligned}
& (c/(\mathbf{C}^{\text{op}}))^{\text{op}}(f^{\text{op}}, g^{\text{op}}) \\
&= (c/(\mathbf{C}^{\text{op}}))(g^{\text{op}}, f^{\text{op}}) \\
&= \{i^{\text{op}} \in \mathbf{C}^{\text{op}}(y, x) \mid i^{\text{op}}g^{\text{op}} = f^{\text{op}}\} \times \{(g^{\text{op}}, f^{\text{op}})\} \\
&= \{i \in \mathbf{C}(x, y) \mid gi = f\} \times \{(f, g)\} \\
&= (\mathbf{C}/c)(f, g)
\end{aligned}$$

as required.

Notice also in this correspondence that when $f = g$ that the identities in each class are the same. Altogether, $1_{f^{\text{op}}}^{\text{op}} = 1_f$.

Now, we must see that the composition laws are the same. We have already established above that $i^{\text{op}'}i^{\text{op}} = i'$. Similarly, if $j': g \rightarrow h$, then we have $j^{\text{op}'}i^{\text{op}}i^{\text{op}'}: f^{\text{op}} \rightarrow h^{\text{op}}$. But, examining the definitions of opposite categories and of slice categories, we have equality of each of the following morphisms interpreted in the categories shown

$$\begin{array}{ll}
j^{\text{op}'}i^{\text{op}}i^{\text{op}'}: f^{\text{op}} \rightarrow h^{\text{op}} & \text{in } (c/(\mathbf{C}^{\text{op}}))^{\text{op}} \\
i^{\text{op}'}j^{\text{op}'}: h^{\text{op}} \rightarrow f^{\text{op}} & \text{in } c/(\mathbf{C}^{\text{op}}) \\
(i^{\text{op}}j^{\text{op}})': h^{\text{op}} \rightarrow f^{\text{op}} & \text{in } c/(\mathbf{C}^{\text{op}}) \\
i^{\text{op}}j^{\text{op}}: z \rightarrow x & \text{in } \mathbf{C}^{\text{op}} \\
ji: x \rightarrow z & \text{in } \mathbf{C} \\
(ji)': f \rightarrow h & \text{in } \mathbf{C}/c \\
j'i': f \rightarrow h & \text{in } \mathbf{C}/c
\end{array}$$

This proves that the two categories share the same composition law. Thus, they are one and the same.

Now, looking back at Exercise 1.1.iii, we see that we could have defined \mathbf{C}/c as $(c/(\mathbf{C}^{\text{op}}))^{\text{op}}$, so that the existence of the category \mathbf{C}/c follows from the existence of $c/(\mathbf{C}^{\text{op}})$, which we have by the first part of Exercise 1.1.iii applied to \mathbf{C}^{op} . \square

EXERCISE 1.2.ii.

- (i) Show that a morphism $f: x \rightarrow y$ is a split epimorphism in a category \mathbf{C} if and only if for all $c \in \mathbf{C}$, post-composition $f_*: \mathbf{C}(c, x) \rightarrow \mathbf{C}(c, y)$ defines a surjective function.

PROOF. First, assume that f is a split epimorphism and that $c \in \text{ob } \mathbf{C}$. That is, there exists a function $g: y \rightarrow x$ such that $fg = 1_y$. Now, consider the function $f_*: \mathbf{C}(c, x) \rightarrow \mathbf{C}(c, y)$. We know that this function corresponds to composition on

the left by f , so in order for this function to be surjective, for every $k: c \rightarrow y$, there must exist a $j: c \rightarrow x$ such that $fj = k$. Now, for an arbitrary k , consider $j = gk$. It is easy to see that $gk: c \rightarrow x$, and that $f_*(gk) = f(gk) = (fg)k = 1_y k = k$. Since we can construct j in this way for every $k \in \mathbf{C}(c, y)$, we see that f_* is surjective.

Now, assume that f_* is surjective, that is, for any choice of $c \in \mathbf{C}$, and any $k \in \mathbf{C}(c, y)$, $k = fg$, for some $g \in \mathbf{C}(c, x)$. Now, suppose $c = y$ and $k = 1_y$, so we have that there exists a $g \in \mathbf{C}(y, x)$ where $fg = 1_y$, and this implies that f is a split epimorphism. \square

- (ii) Argue by duality that f is a split monomorphism if and only if for all $c \in \mathbf{C}$, pre-composition $f^*: \mathbf{C}(y, c) \rightarrow \mathbf{C}(x, c)$ is a surjective function.

PROOF. We know that if f^{op} is a split epimorphism, that $f_*^{\text{op}}: \mathbf{C}^{\text{op}}(c, y) \rightarrow \mathbf{C}^{\text{op}}(c, x)$ is surjective. However, if we consider the definitions of f^{op} and split monomorphisms and epimorphisms, we see that f^{op} being a split epimorphism implies that f is a split monomorphism. We also see that $f_*^{\text{op}}: \mathbf{C}^{\text{op}}(c, y) \rightarrow \mathbf{C}^{\text{op}}(c, x)$ is equivalent to $f^*: \mathbf{C}(y, c) \rightarrow \mathbf{C}(x, c)$. So we have that f is a split monomorphism if and only if $f^*: \mathbf{C}(y, c) \rightarrow \mathbf{C}(x, c)$ is surjective. \square

LEMMA 1.2.11.

- (i) If $f: x \rightarrow y$ and $g: y \rightarrow z$ are monomorphisms, then so is $gf: x \rightarrow z$.
(ii) If $f: x \rightarrow y$ and $g: y \rightarrow z$ are morphisms so that gf is monic, then f is monic.

Dually:

- (i') If $f: x \rightarrow y$ and $g: y \rightarrow z$ are epimorphisms, then so is $gf: x \rightarrow z$.
(ii') If $f: x \rightarrow y$ and $g: y \rightarrow z$ are morphisms so that gf is epic, then g is epic.

EXERCISE 1.2.iii. Prove Lemma 1.2.11 by proving either (i) or (i') and either (ii) or (ii'), then arguing by duality. Conclude that the monomorphisms in any category define a subcategory of that category and dually that the epimorphisms also define a subcategory.

First we will show the above properties for monomorphisms, and then apply duality, as the problem suggests, to prove the corresponding properties for epimorphisms.

PROOF. First, we will prove that the composition of two monomorphisms is a monomorphism. Let \mathbf{C} be a category and $f: x \rightarrow y$ and $g: y \rightarrow z$ be monomorphisms of \mathbf{C} . Let $h, k: w \rightarrow x$ be two morphisms in \mathbf{C} so that: $(gf)h = (gf)k$. Since composition of morphisms is associative, we have $g(fh) = g(fk)$. Since g is monic, we get: $fh = fk$. Since f is monic, we ultimately get: $h = k$. Thus, gf is monic. Thus, the composition of two monomorphisms is indeed a monomorphism.

Next we will show that if the composition of two morphisms is monic, then the rightmost morphism is monic. Take morphisms $a: x \rightarrow y$ and $b: y \rightarrow z$ from category \mathbf{C} where ba is monic. Take $h, k: w \rightarrow x$ so that $ah = ak$. Left composing b on both sides of the equations results in: $b(ah) = b(ak)$. By associativity we get: $(ba)h = (ba)k$. Applying the properties of monomorphisms results in: $h = k$. Thus a is monic. So we have shown that if the composition of two morphisms is monic, then the rightmost morphism is monic.

Now we will show that the monomorphisms of any category forms a category. Suppose that D is a subcategory of C where the morphisms of D are the monomorphisms of C and D and C have the same objects. Since for any object x in C , if we had for morphisms h and k of C with codomain x the following property: $1_x h = 1_x k$, then $h = k$, since 1_x is left cancellable, thus the identity morphism for every object in D is a monomorphism. Therefore, every object in D has an identity arrow in D . Since the composition of two monomorphisms is a monomorphism, then D contains compositions of its morphisms. Obviously, the domains and codomains of morphisms of D are contained in D since D and C have the same objects. Thus D is a subcategory of C .

We have shown that:

- The composition of two monomorphisms in C is a monomorphism,
- if the composition of two morphisms in C is monic, then the rightmost morphism is monic, and
- the class of monomorphisms of any category C forms a subcategory of C .

Now we will use duality to show the corresponding properties for epimorphisms. If we have the opposite category C^{op} , where the epimorphisms of C are the monomorphisms of C^{op} , this means that the three properties proven for monomorphisms also work for C^{op} . The properties of monomorphisms in C^{op} are the dual properties of epimorphisms in $(C^{op})^{op} = C$. We will show that:

- the composition of two epimorphisms in C is an epimorphism,
- if the composition of two morphisms in C is epic, then the leftmost morphism is epic (since $f^{op}g^{op}$ in C^{op} corresponds to gf in C), and
- the class of epimorphisms of any category C forms a subcategory of C .

This completes the proof. □

DEFINITION 1.2.7. A morphism $f: x \rightarrow y$ in a category is

- (i) a *monomorphism* if for any parallel morphisms $h, k: w \rightrightarrows x$, $fh = fk$ implies that $h = k$; or
- (ii) an *epimorphism* if for any parallel morphisms $h, k: y \rightrightarrows z$, $hf = kf$ implies that $h = k$.

EXERCISE 1.2.iv. What are the monomorphisms in the category of fields?

PROOF. In the category of fields, morphisms are field homomorphisms. Let $f: A \rightarrow B$ be a morphism in Field . As f is a field homomorphism, its kernel is an ideal in B . Since B is a field, there are only two ideals: $\{0\}$ and B itself. The kernel of f cannot be the whole field, since this would be the zero morphism which is not a field homomorphism. So $\ker f = \{0\}$ and from this, f is injective, and in particular it is left cancellable.

Let h and k be morphisms in Field for which composition with f makes sense and say that

$$fh = fk.$$

Since f is left cancellable, this implies that

$$h = k,$$

and f is a monomorphism by Definition 1.2.7(i) above. (In fact, injections are monomorphisms in any category in which the objects have “underlying sets”.)

Thus, all of the morphisms in \mathbf{Field} are monomorphisms. □

EXERCISE 1.2.v. Show that the inclusion $\mathbb{Z} \hookrightarrow \mathbb{Q}$ is both a monomorphism and an epimorphism in the category \mathbf{Ring} of rings. Conclude that a map that is both monic and epic need not be an isomorphism.

PROOF. Note first that monic and epic correspond to a map being cancellable on the left and right, whereas an isomorphism is by definition invertible. It is easy to see that invertibility implies cancellability; however the converse need not be true. Looking at the monoid of natural numbers under addition, every element is cancellable; however none except zero is invertible. Because every monoid is a category this gives us an elementary example where a map that is monic and epic is not an isomorphism. However, this example might seem simplistic and it is worth asking whether there is an example of cancellability not implying invertibility in a “larger” category where the arrows represent actual maps.

Recall that \mathbb{Q} is the localisation of \mathbb{Z} with respect to its cancellable elements $\mathbb{Z} \setminus \{0\}$. The immediate result of this is the existence of a natural embedding $\iota: \mathbb{Z} \rightarrow \mathbb{Q}$ that is an injective ring homomorphism. Further, this embedding has the following universal property: given a ring R and a homomorphism $\phi: \mathbb{Z} \rightarrow R$ such that $\phi(q)$ has an inverse for all $q \in \mathbb{Z}$, there is a unique ring homomorphism $\psi: \mathbb{Q} \rightarrow R$ such that the following diagram commutes.

$$\begin{array}{ccc}
 \mathbb{Z} & \xrightarrow{\phi} & R \\
 & \searrow \iota & \nearrow \psi \\
 & \mathbb{Q} &
 \end{array}$$

Note further that there is a unique ring homomorphism from \mathbb{Z} to any ring R which maps \mathbb{Z} onto the subring generated by the multiplicative identity of R . This implies that there can be at most one homomorphism from \mathbb{Q} to any ring R . If $\psi: \mathbb{Q} \rightarrow R$ is a ring homomorphism, then $\psi \iota: \mathbb{Z} \rightarrow R$ must be the unique homomorphism from \mathbb{Z} to R and thus ψ is the unique homomorphism specified by the universal property.

Supposing $h, k: \mathbb{Q} \rightarrow R$ are parallel homomorphisms, they are equal by virtue of the fact that there is at most one homomorphism from \mathbb{Q} to R , and ι vacuously fulfils the condition of an epimorphism. □

EXERCISE 1.2.vi. Prove that a morphism that is both a monomorphism and a split epimorphism is necessarily an isomorphism. Argue by duality that a split monomorphism that is an epimorphism is also an isomorphism.

$$\begin{array}{ccc}
 & \xrightarrow{f} & \\
 gf \circlearrowleft & x & \xrightarrow{f} y \circlearrowright 1_y \\
 & \xleftarrow{g} &
 \end{array}$$

PROOF. Let \mathbf{C} be a category with objects x and y and a morphism $f: x \rightarrow y$. If f is a split epimorphism, then there exists another morphism $g: y \rightarrow x$ such that $fg = 1_y$. If f is also a monomorphism, then for any object w and any parallel pair of morphisms $h, k: w \rightrightarrows x$, $fh = fk$ implies that $h = k$. Combining these facts with some basic algebra:

$$\begin{array}{ll} 1_y f = f 1_x & \text{definition of identities,} \\ fgf = f 1_x & g \text{ is a right inverse of } f, \\ gf = 1_x & f \text{ is left cancellable,} \end{array}$$

gives that g is also a left inverse of f .

Suppose instead that f is an epimorphism and a split monomorphism with left inverse g in the category \mathbf{C} . Then it is also a monomorphism and a split epimorphism in \mathbf{C}^{op} , thus f is an isomorphism in \mathbf{C}^{op} and an isomorphism in \mathbf{C} . \square

EXERCISE 1.2.vii. Regarding a poset (\mathbf{P}, \leq) as a category, define the supremum of a subcollection of objects $A \in \mathbf{P}$ in such a way that the dual statement defines the infimum. Prove that the supremum of a subset of objects is unique, whenever it exists, in such a way that the dual proof demonstrates the uniqueness of the infimum.

PROOF. Given a subcollection C of objects $A \in \mathbf{P}$, define an upper bound as follows: a object u is an upper bound of C if for all objects x in C there is a morphism $x \leq u: x \rightarrow u$. (Recall that morphisms in a poset category are merely elements of the \leq relation.) Note that this immediately gives us a dual notion of a lower bound by considering instead \mathbf{P}^{op} . A lower bound of C in \mathbf{P} is an upper bound of C in \mathbf{P}^{op} . In other words an object l^{op} such that for all objects x^{op} in C there is a morphism $(x \leq l)^{\text{op}}: x^{\text{op}} \rightarrow l^{\text{op}}$, or equivalently $(l \leq x): l \rightarrow x$.

Letting F be the collection of all upper bounds of C , we define the supremum of C , if it exists³, to be a lower bound of F (as defined above) which is contained in F . The condition of containment implies uniqueness. Supposing we have two lower bounds x and y of F . If both are contained in F , then there are maps $x \leq y: x \rightarrow y$ and $y \leq x: y \rightarrow x$. Since the only endomorphisms in \mathbf{P} are identities these must compose to identities and thus be inverses, and because \mathbf{P} is a partially ordered set (as opposed to just being a preordered set)

³There are many cases where suprema fail to exist. Consider the poset category:

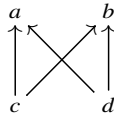

the set $\{c, d\}$ has as upper bounds $\{a, b\}$. However, $\{a, b\}$ has as lower bounds $\{c, d\}$. Because these sets are disjoint there is no supremum of $\{c, d\}$. Even in more common orderings, like the usual ordering on the rational numbers, subcollections can fail to have suprema. For example, $\{x \in \mathbb{Q} \mid x^2 < 2\}$.

A poset with the property that any collection of elements has a supremum and infimum is called a complete lattice.

the only isomorphisms are identities. In familiar terms, a partial order is antisymmetric. Thus x and y are the same object.

We may thus define the infimum of C to be its supremum on \mathbf{P}^{op} . This time we consider the collection I of lower bounds C (the upper bounds of C in \mathbf{P}^{op}). The infimum is then an upper bound of I which is contained in I (a lower bound in \mathbf{P}^{op}). The infimum must be unique because it's a supremum in the opposite category, and suprema are unique. \square

1.3 Functoriality

EXERCISE 1.3.i. What is a functor between groups, regarded as one-object categories?

PROOF. Recall that a group as a category has a single object x , and that each element of the group is a morphism in the category. All domains and codomains are that object x . There is one identity morphism 1_x , which is the identity element in the group. Composition is the same as multiplication in this context.

A functor between groups \mathbf{C} and \mathbf{D} with respective objects x_1 and x_2 must trivially be such that $Fx_1 = x_2$. Our primary concern is the behavior of the functor on the morphisms. We require that for a functor $F1_x = 1_{Fx}$ for all objects $x \in \text{ob } \mathbf{C}$, which in this case just implies that 1_{x_1} is taken to 1_{x_2} . Additionally, we require $F(\text{dom}(f)) = \text{dom}(Ff)$ and $F(\text{cod}(f)) = \text{cod}(Ff)$ for all morphisms f in the first category. This is a trivial requirement, as $F(\text{dom}(f)) = \text{dom}(Ff) = F(\text{cod}(f)) = \text{cod}(Ff) = x_2$ regardless of f . Finally we require that if f and g are a composable pair of morphisms in \mathbf{C} , then $F(fg) = FfFg$. However, all morphisms in \mathbf{D} are composable, and this implies that $F(f * g) = Ff * Fg$ in the notation of groups with operation $*$. This property and the preservation of identities are directly the definition of a group homomorphism, so this functor is simply a group homomorphism. \square

EXERCISE 1.3.ii. What is a functor between preorders, regarded as categories?

PROOF. Recall that a preorder regarded as a category has objects that are the elements of the underlying set of the preorder, and has morphisms that are the related pairs. Identities are the unique morphisms (x, x) , which exist based on the reflexivity of the relation. Note that if (a, b) and (b, c) are in the relation, the composition will be $(b, c)(a, b) = (a, c)$.

What do the properties of a functor between preorders \mathbf{C} (with relation R) and \mathbf{D} (with relation S) tell us? First, we know that $F1_x = 1_{Fx}$ for all $x \in \text{ob } \mathbf{C}$. This implies that the morphism (x, x) must be brought to the morphism (Fx, Fx) . This becomes redundant with the next step.

We also know that $F(\text{dom}(f)) = \text{dom}(Ff)$ for all $f \in \text{mor } \mathbf{C}$. If $f = (a, b)$, then $F(\text{dom}(f)) = F(a)$ and thus Ff must be a pair $(F(a), z_1)$ for some $z_1 \in \text{ob } \mathbf{D}$. Similarly, $F(\text{cod}(f)) = \text{cod}(Ff)$ implies that if $f = (a, b)$, then $F(\text{cod}(f)) = Fb$ and Ff must be a pair (z_2, Fb) . Combining these, we get that Ff for $f = (a, b)$ must be a pair (Fa, Fb) . This means that if $(a, b) \in R$ then $(Fa, Fb) \in S$.

Thus, F provides us a preorder homomorphism, as F preserves related pairs. The final property to check for a functor is composable pairs. If two morphisms f and g are

composable, then $F(fg) = FfFg$. This means

$$F((b, c)(a, b)) = F(a, c) = (Fb, Fc)(Fa, Fb) = (Fa, Fc),$$

which was already confirmed by the previous property. Thus, the functor is a preorder homomorphism. \square

EXERCISE 1.3.iii. Find an example to show that the objects and morphisms in the image of a functor $F: \mathbf{C} \rightarrow \mathbf{D}$ do not necessarily define a subcategory of \mathbf{D} .

At first, I was suspicious of this exercise since it seemed to me that the proof that the image of a group (or monoid, or ring, . . .) homomorphism is a subgroup (or submonoid, or subring, . . .) carries through without any change. Perhaps the author meant for the exercise to be something different?

So, I asked her, and she pointed out a straightforward example that also exposed the error in my reasoning. I will give below a simplification of the example that she sent me. First, here is the error in my original argument.

Let a and b be morphisms in the image of F such that $\text{dom } a = \text{cod } b$ so that we can form ab in \mathbf{D} . Since a and b are in the image of F , there are morphisms f and g in \mathbf{C} such that $a = Ff$ and $b = Fg$. Then

$$ab = FfFg = F(fg)$$

so that ab is in the image of F .

Right? Wrong!! In order to compose f and g we need that $\text{dom } f = \text{cod } g$. All we know for sure is that $\text{dom } Ff = \text{cod } Fg$. If F is injective on objects, then the argument above is valid. But perhaps F is not injective.

The Example.

Now, I provide the example requested in this exercise. Let $\mathbf{C} = \mathbf{2}$ be the ordinal category pictured as so:

$$0 \xrightarrow{f} 1.$$

Let g be an endomorphism of some object x in some category \mathbf{D} such that gg is equal to neither 1_x nor g . For example, we could take x to be the unique object in $B\mathbb{N}$ and $g = 3$. Composition of morphisms in $B\mathbb{N}$ is addition in \mathbb{N} so that $gg = g + g = 6 \neq 3, 0$.

Then we have a functor $F: \mathbf{2} \rightarrow \mathbf{D}$ given by $F0 = F1 = x$, $F1_0 = F1_1 = 1_x$ and $Ff = g$. There are only four possible compositions of the three morphisms in $\mathbf{2}$, 1_01_0 , $f1_0$, 1_1f and 1_11_1 and it is easy to see that F preserves all four of these compositions. Thus, F is a functor.

However, the image of F has only the two morphisms 1_x and g . Since gg is not in the image, the image of F is not a subcategory of \mathbf{D} .

LEMMA 1.2.3. *The following are equivalent:*

- (i) $f: x \rightarrow y$ is an isomorphism in \mathcal{C} .
- (ii) For all objects $c \in \mathcal{C}$, post-composition with f defines a bijection

$$f_*: \mathcal{C}(c, x) \rightarrow \mathcal{C}(c, y)$$

- (iii) For all objects $c \in \mathcal{C}$, pre-composition with f defines a bijection

$$f^*: \mathcal{C}(y, c) \rightarrow \mathcal{C}(x, c)$$

DEFINITION 1.3.1. A *functor* F from \mathcal{C} to \mathcal{D} is a functor $F: \mathcal{C} \rightarrow \mathcal{D}$. Explicitly, this consists of the following data:

- An object $Fc \in \mathcal{D}$, for each object $c \in \mathcal{C}$.
- A morphism $Ff: Fc \rightarrow Fc' \in \mathcal{D}$, for each morphism $f: c \rightarrow c' \in \mathcal{C}$, so that the domain and codomain of Ff are, respectively, equal to F applied to the domain or codomain of f .

The assignments are required to satisfy the following two *functoriality axioms*:

- For any composable pair f, g in \mathcal{C} , $FgFf = F(gf)$.
- For each object c in \mathcal{C} , $F(1_c) = 1_{Fc}$.

The functors defined in 1.3.1 are called *covariant* so as to distinguish them from another variety of functor that we now introduce.

DEFINITION 1.3.5. A *contravariant functor* F from \mathcal{C} to \mathcal{D} is a functor $F: \mathcal{C}^{\text{op}} \rightarrow \mathcal{D}$. Explicitly, this consists of the following data:

- An object $Fc \in \mathcal{D}$, for each object $c \in \mathcal{C}$.
- A morphism $Ff: Fc' \rightarrow Fc \in \mathcal{D}$, for each morphism $f: c \rightarrow c' \in \mathcal{C}$, so that the domain and codomain of Ff are, respectively, equal to F applied to the codomain or domain of f .

The assignments are required to satisfy the following two *functoriality axioms*:

- For any composable pair f, g in \mathcal{C} , $FfFg = F(gf)$.
- For each object c in \mathcal{C} , $F(1_c) = 1_{Fc}$.

DEFINITION 1.3.11. If \mathcal{C} is locally small, then for any object $c \in \mathcal{C}$ we may define a pair of covariant and contravariant *functors represented by c* :

$$\begin{array}{ccc}
 \mathcal{C} & \xrightarrow{\mathcal{C}(c, -)} & \mathbf{Set} & & \mathcal{C}^{\text{op}} & \xrightarrow{\mathcal{C}(-, c)} & \mathbf{Set} \\
 \\
 x & \mapsto & \mathcal{C}(c, x) & & x & \mapsto & \mathcal{C}(x, c) \\
 \downarrow f & \mapsto & \downarrow f_* & & \downarrow f & \mapsto & \uparrow f^* \\
 y & \mapsto & \mathcal{C}(c, y) & & y & \mapsto & \mathcal{C}(y, c)
 \end{array}$$

The notation suggests the action on objects: the functor $\mathbf{C}(c, -)$ carries $x \in \mathbf{C}$ to the set $\mathbf{C}(c, x)$ of arrows from c to x in \mathbf{C} . Dually, the functor $\mathbf{C}(-, c)$ carries $x \in \mathbf{C}$ to the set $\mathbf{C}(x, c)$.

The functor $\mathbf{C}(c, -)$ carries a morphism $f: x \rightarrow y$ to the post-composition function $f_*: \mathbf{C}(c, x) \rightarrow \mathbf{C}(c, y)$ introduced in Lemma 1.2.3(ii). Dually, the functor $\mathbf{C}(-, c)$ carries f to the pre-composition function $f^*: \mathbf{C}(y, c) \rightarrow \mathbf{C}(x, c)$ introduced in 1.2.3(iii).

EXERCISE 1.3.iv. Verify that the constructions in Definition 1.3.11 are functorial.

PROOF. We start by showing that the assignments of $\mathbf{C}(c, -)$ satisfy the functoriality axioms for (covariant) functors. The actions of dom and cod on $\mathbf{C}(c, -)$ can be seen as follows: applying $\mathbf{C}(c, -)$ to a morphism $h: i \rightarrow j$ will give a morphism $\mathbf{C}(c, -)(h): \mathbf{C}(c, \text{dom } h) \rightarrow \mathbf{C}(c, \text{cod } h)$, so $\text{dom } \mathbf{C}(c, -)(h) = \mathbf{C}(c, i)$ and $\text{cod } \mathbf{C}(c, -)(h) = \mathbf{C}(c, j)$.

To show composition, let $f: x \rightarrow y$ and $g: w \rightarrow x$ be a composable pair of morphisms in \mathbf{C} . Note first that $fg: w \rightarrow y$ and that $\mathbf{C}(c, -)(f): \mathbf{C}(c, x) \rightarrow \mathbf{C}(c, y)$, and finally that $\mathbf{C}(c, -)(g): \mathbf{C}(c, w) \rightarrow \mathbf{C}(c, x)$.

Since $\text{dom } \mathbf{C}(c, -)(f) = \text{cod } \mathbf{C}(c, -)(g) = \mathbf{C}(c, x)$, we can compose as follows:

$$\mathbf{C}(c, -)(f) (\mathbf{C}(c, -)(g)): \mathbf{C}(c, w) \rightarrow \mathbf{C}(c, y).$$

Since $\mathbf{C}(c, -)(fg)$ and $\mathbf{C}(c, -)(f) (\mathbf{C}(c, -)(g))$ are given by applying fg to a morphism in $\mathbf{C}(c, w)$, we have that $\mathbf{C}(c, -)(f)\mathbf{C}(c, -)(g) = \mathbf{C}(c, -)(fg)$, satisfying functor composition.

To show that identities are preserved, note that for any object $x \in \mathbf{C}$, $1_x: x \rightarrow x$. Then $\mathbf{C}(c, -)(1_x): \mathbf{C}(c, x) \rightarrow \mathbf{C}(c, x)$ taking 1_x to the post composition $1_x^*: \mathbf{C}(c, x) \rightarrow \mathbf{C}(c, x)$. Since for any morphism $a \in \mathbf{C}(c, x)$, 1_x^* takes $a \mapsto 1_x a$, this is the identity $a \mapsto a$. Then consider $1_{\mathbf{C}(c, -(x))} = 1_{\mathbf{C}(c, x)}$, which is the identity of $\mathbf{C}(c, x)$, taking each element a of the set to itself: $a \mapsto a$. Thus, $\mathbf{C}(c, -)(1_x) = 1_{\mathbf{C}(c, -(x))}$ and $\mathbf{C}(c, -)$ preserves identities, as show by the following diagram.

$$\begin{array}{ccc} c & \xrightarrow{a} & x \\ & \searrow & \downarrow 1_x \\ & & y = x \end{array}$$

$1_x a$

To see that $\mathbf{C}(-, c)$ is a contravariant functor, we argue by duality. Since $\mathbf{C}(c, -): \mathbf{C} \rightarrow \mathbf{Set}$ is a functor for any category \mathbf{C} , we have that $\mathbf{C}^{\text{op}}(c, -): \mathbf{C}^{\text{op}} \rightarrow \mathbf{Set}$ is also a functor. Additionally, it is contravariant since the definition a contravariant functor is a functor from \mathbf{C}^{op} to \mathbf{Set} . Given that $\mathbf{C}^{\text{op}}(c, -) = \mathbf{C}(-, c)$, we know that $\mathbf{C}(-, c)$ is a contravariant functor, completing the proof. \square

EXERCISE 1.3.v. What is the difference between a functor $\mathbf{C}^{\text{op}} \rightarrow \mathbf{D}$ and a functor $\mathbf{C} \rightarrow \mathbf{D}^{\text{op}}$? What is the difference between a functor $\mathbf{C} \rightarrow \mathbf{D}$ and a functor $\mathbf{C}^{\text{op}} \rightarrow \mathbf{D}^{\text{op}}$?

PROOF. We will show that if F is a functor from $\mathbf{C} \rightarrow \mathbf{D}$, then F is also a functor from \mathbf{C}^{op} to \mathbf{D}^{op} , and then deduce the relationship between a functor $\mathbf{C}^{\text{op}} \rightarrow \mathbf{D}$ and a functor $\mathbf{C} \rightarrow \mathbf{D}^{\text{op}}$ as a special case.

Let F be a functor from $\mathbf{C} \rightarrow \mathbf{D}$. We will show that F is also a functor from \mathbf{C}^{op} to \mathbf{D}^{op} directly from the functoriality axioms. That is for objects x, y , and z in \mathbf{C} and any two composable morphisms $f: x \rightarrow y$ and $g: y \rightarrow z$ in \mathbf{C} , we must have $F(fg) = FfFg$ and $F1_x = 1_{F_x}$. Since for each object in \mathbf{C} and \mathbf{D} the identity maps are the same in their respective opposite categories, we only need to verify that F respects composition when take composable morphisms from \mathbf{C}^{op} to \mathbf{D}^{op} . Since both the objects \mathbf{C}^{op} and \mathbf{D}^{op} and morphisms \mathbf{C} and \mathbf{D} are exactly the same, but the morphisms have their domains and codomains swapped, we let $f: y \rightarrow x$ and $g: z \rightarrow y$ be morphisms in \mathbf{C}^{op} . Now observe that since F respects composition in \mathbf{C} we have, $Fgf = FgFf$, and F is a functor from \mathbf{C}^{op} to \mathbf{D}^{op} . Now since $\mathbf{C} = (\mathbf{C}^{\text{op}})^{\text{op}}$ and $\mathbf{D} = (\mathbf{D}^{\text{op}})^{\text{op}}$ we see that there is no difference from a functor $\mathbf{C}^{\text{op}} \rightarrow \mathbf{D}$ and a functor $\mathbf{C} \rightarrow \mathbf{D}^{\text{op}}$ as well. \square

EXERCISE 1.3.vi. Given functors $F: \mathbf{D} \rightarrow \mathbf{C}$ and $G: \mathbf{E} \rightarrow \mathbf{C}$, show that there is a category, called the **comma category** $F \downarrow G$, which has

1. as objects, triples $(d \in \mathbf{D}, e \in \mathbf{E}, f: Fd \rightarrow Ge \in \mathbf{C})$, and
2. as morphisms $(d, e, f) \rightarrow (d', e', f')$, a pair of morphisms $(h: d \rightarrow d', k: e \rightarrow e')$ so that the square

$$\begin{array}{ccc} Fd & \xrightarrow{f} & Ge \\ Fh \downarrow & & \downarrow Gk \\ Fd' & \xrightarrow{f'} & Ge' \end{array}$$

commutes in \mathbf{C} , i.e., so that $f'Fh = Gkf$.

Define a pair of projection functors $\text{dom}: F \downarrow G \rightarrow \mathbf{D}$ and $\text{cod}: F \downarrow G \rightarrow \mathbf{E}$

PROOF. Before we prove that the comma category $F \downarrow G$ is actually a category, we need to give a motivating example for a major issue in the proof.

Let $A: \mathbf{2} \rightarrow \mathbf{Set}$ and $B: \mathbf{2} \rightarrow \mathbf{Set}$ be functors where $A0 = \{0\}$, $A1 = \{0, 1, 2\}$, $B0 = \{0, 1\}$, $B1 = \{0, 1, 2, 3\}$ and where A and B maps the unique morphism $f: 0 \rightarrow 1$ to the inclusion functions $\iota: \{0\} \rightarrow \{0, 1, 2\}$ and $\iota: \{0, 1\} \rightarrow \{0, 1, 2, 3\}$ respectively. Let us take our supposed objects $(0, 0, \iota)$ and $(1, 1, \alpha)$ where ι is the inclusion function and our supposed morphism $(f: 0 \rightarrow 1, f: 0 \rightarrow 1)$ so that the diagram

$$\begin{array}{ccc} A0 & \xrightarrow{\iota} & B0 \\ Af \downarrow & & \downarrow Bf \\ A1 & \xrightarrow{\alpha} & B1 \end{array}$$

commutes. Now there are at least two functions for α that would allow the diagram above to commute. The first is if α was simply an inclusion function so the functions αAf and

$Bf\iota$ are inclusion functions from the singleton set $A0$ to $B1$, thus $\alpha Af = Bf\iota$. The second function which I will denote α' is defined as follows:

$$\alpha'(0) = 0, \alpha'(1) = 2, \alpha'(2) = 1.$$

Since α' still maps 0 in $A1$ to itself in $B1$, the diagram above still commutes. Thus our supposed morphism $(f: 0 \rightarrow 1, f: 0 \rightarrow 1)$ would have two codomains $((1, 1, \alpha)$ and $(1, 1, \alpha'))$ for our domain $(0, 0, \iota)$.

This example shows we need additional notation to distinguish between arrows that are represented the same but have different domains and codomains. Returning to the notation established in the first paragraph, we will append morphism pairs (f, f') to the end of some morphism $(h: d \rightarrow d', k: e \rightarrow e')$ so that we specify that the intended domain and codomain of the morphism is (d, e, f) and (d', e', f') respectively. Thus the uniqueness of the domain and codomain of some morphism $(h: d \rightarrow d', k: e \rightarrow e')$ (f, f') follows from the uniqueness of the domain and codomain of h and k , and additionally from our notation which specifies unique morphisms f and f' . Now we can complete the rest of the proof using the notation established in the first paragraph.

For an object (d, e, f) , denoted as c , we can define an identity morphism for c as the following:

$$1_c = (1_d, 1_e) (f, f)$$

where 1_d and 1_e are the respective identities of d and e . Thus the diagram

$$\begin{array}{ccc} Fd & \xrightarrow{f} & Ge \\ F1_d \downarrow & & \downarrow G1_e \\ Fd & \xrightarrow{f} & Ge \end{array}$$

trivially commutes. The unique domain and codomain of 1_c , both being (d, e, f) , are derived from the unique domain and codomains of the identities 1_d and 1_e , and the uniquely specified f .

Now let us define morphism composition between two morphisms.

$$(h: d \rightarrow d_1, k: e \rightarrow e_1) (f, f_1) \text{ and } (h': d_1 \rightarrow d_2, k': e_1 \rightarrow e_2) (f_1, f_2)$$

which we will denote

$$\alpha: (d, e, f) \rightarrow (d_1, e_1, f_1) \text{ and } \beta: (d_1, e_1, f_1) \rightarrow (d_2, e_2, f_2).$$

The composition of α and β shall be defined as follows:

$$\beta\alpha = (h'h: d \rightarrow d_2, k'k: e \rightarrow e_2) (f, f_2)$$

resulting in the diagram

$$\begin{array}{ccc}
 Fd & \xrightarrow{f} & Ge \\
 Fh \downarrow & & \downarrow Gk \\
 Fd_1 & \xrightarrow{f_1} & Ge_1 \\
 Fh' \downarrow & & \downarrow Gk' \\
 Fd_2 & \xrightarrow{f_2} & Ge_2
 \end{array}$$

which commutes since functors preserve composition of morphisms and the top and bottom squares commute by construction of α and β ⁴. Thus we have that the following diagram commutes:

$$\begin{array}{ccc}
 Fd & \xrightarrow{f} & Ge \\
 Fh'Fh \downarrow & & \downarrow Gk'Gk \\
 Fd_2 & \xrightarrow{f_2} & Ge_2
 \end{array}$$

which is the commutative square for the composed morphism $\beta\alpha$. The morphism $\beta\alpha$ derives its unique domain from the unique domains of $h'h$ and $k'k$ and the specified function f which gives the domain (d, e, f) which is the domain of α , and the unique codomain is derived similarly resulting in the codomain (d_2, e_2, f_2) which is the codomain of β . So the composition of morphisms α and β gives a morphism $\beta\alpha$ with the domain of α and the codomain of β .

Now that we have defined the identity morphism and composition of morphism, we can show that the identity morphism is left and right cancellable, and that composition is associative.

Let $(h: d \rightarrow d', k: e \rightarrow e')(f, f')$, denoted as α , be a morphism with domain and codomain (d, e, f) and (d', e', f') respectively, denoted as c and c' respectively. Starting with the composition of α and 1_c , we can show the following chain of equalities:

$$\begin{aligned}
 \alpha 1_c &= (h1_d, k1_e)(f, f') \\
 &= (h, k)(f, f') \\
 &= \alpha.
 \end{aligned}$$

Composing $1_{c'}$ and α gives us a similar result:

$$\begin{aligned}
 1_{c'}\alpha &= (1_{d'}h, 1_{e'}k)(f, f') \\
 &= (h, k)(f, f') \\
 &= \alpha.
 \end{aligned}$$

Thus we have shown that $1_{c'}\alpha = \alpha = \alpha 1_c$. Therefore the identity morphism is left and right cancellable.

⁴See diagram 1.6.10.

Finally, we will show that the composition of morphisms is associative. Take morphisms $(h: d \rightarrow d_1, k: e \rightarrow e_1) (f, f_1)$, $(h: d_1 \rightarrow d_2, k: e_1 \rightarrow e_2) (f_1, f_2)$, and $(h: d_2 \rightarrow d_3, k: e_2 \rightarrow e_3) (f_2, f_3)$, denoted as α, β , and γ respectively. Now observe that:

$$\begin{aligned} (\gamma\beta)\alpha &= ((h_2h_1), (k_2k_1))(f_1, f_3)\alpha \\ &= ((h_2h_1)h, (k_2k_1)k)(f, f_3) \\ &= (h_2(h_1h), k_2(k_1k))(f, f_3) \\ &= \gamma((h_1h), (k_1k))(f, f_2) \\ &= \gamma(\beta\alpha). \end{aligned}$$

Thus the composition of morphisms is associative, and we have shown that $F \downarrow G$ is a category.

Now we will define the functors $\text{dom}: F \downarrow G \rightarrow \mathbf{D}$ and $\text{cod}: F \downarrow G \rightarrow \mathbf{E}$ for object (d, e, f) and morphism $(h: d \rightarrow d', k: e \rightarrow e') (f, f')$ as follows:

$$\begin{aligned} \text{dom}(d, e, f) &= d, \text{dom}(h, k) (f, f') = h \\ \text{cod}(d, e, f) &= e, \text{cod}(h, k) (f, f') = k. \end{aligned}$$

Now we will verify that both dom and cod are indeed functors.

Now let us take the morphism $(h: d \rightarrow d_1, k: e \rightarrow e_1) (f, f_1)$ denoted $\alpha: (d, e, f) \rightarrow (d_1, e_1, f_1)$. Applying dom to α gives us $h: d \rightarrow d_1$ where $\text{dom}(d, e, f) = d$ and $\text{dom}(d_1, e_1, f_1) = d_1$. Applying cod to α gives us $k: e \rightarrow e_1$ where $\text{cod}(d, e, f) = e$ and $\text{cod}(d_1, e_1, f_1) = e_1$. Thus $\alpha: (d, e, f) \rightarrow (d_1, e_1, f_1)$ gets mapped to $\text{dom } \alpha: \text{dom}(d, e, f) \rightarrow \text{dom}(d_1, e_1, f_1)$ and $\text{cod } \alpha: \text{cod}(d, e, f) \rightarrow \text{cod}(d_1, e_1, f_1)$ by dom and cod respectively.

For object (d, e, f) , the identity arrow $(1_d, 1_e) (f, f)$ get mapped to 1_d and 1_e by dom and cod respectively. Since $\text{dom}(d, e, f) = d$ and $\text{cod}(d, e, f) = e$, This shows that dom and cod preserve identities.

Finally take morphisms $(h: d \rightarrow d_1, k: e \rightarrow e_1) (f, f_1)$ denoted $\alpha: (d, e, f) \rightarrow (d_1, e_1, f_1)$ and $(h': d_1 \rightarrow d_2, k': e_1 \rightarrow e_2) (f_1, f_2)$ denoted $\beta: (d_1, e_1, f_1) \rightarrow (d_2, e_2, f_2)$. Then we have the following equalities:

$$\text{dom}(\beta\alpha) = \text{dom}(h'h, k'k) (f, f_2) = h'h = \text{dom } \beta \text{ dom } \alpha$$

and

$$\text{cod}(\beta\alpha) = \text{cod}(h'h, k'k) (f, f_2) = k'k = \text{cod } \beta \text{ cod } \alpha.$$

Thus dom and cod preserve morphism composition, and dom and cod are functors. \square

EXERCISE 1.3.vii. Define functors to construct the slice categories c/\mathbf{C} and \mathbf{C}/c as special cases of comma categories. What are the projection functors?

PROOF. We want to choose functors in a comma category, so that the comma category behaves like a slice category. Since the slice category treats morphisms like objects within a

single category, and comma categories are defined generally with three categories in mind, we have some room to reduce the structure of the comma category as we construct a slice category.

Using the notation in the text's definition of the comma category, let $F \downarrow G$ be our comma category. Also, let $D = C$ and let the functor F be the identity functor, 1_C . With this choice of functor, the square in the definition of $F \downarrow G$ still commutes.

At this point, the objects of the comma category are $(d \in C, e \in E, f: d \rightarrow Ge)$. The morphisms are $(h: d \rightarrow d', k: e \rightarrow e')$, such that $(d, e, f) \rightarrow (d', e', f')$.

The above choice of the identity functor collapses the amount of data represented. Yet there remain extra data at this point in the construction to qualify as a slice category. We desire to keep one of the morphisms h and k , while reducing the object-triple $(d \in C, e \in E, f: d \rightarrow Ge)$ to a suitable object-morphism pair, that allows us to fix an element in C , and take morphisms as objects.

To this end, let E be the ordinal category, $\mathbb{1}$, with one object represented as \emptyset , and only the identity morphism. The objects in the comma category now are the triples $(d \in C, \emptyset, f: d \rightarrow c \in C)$. With the functor G acting on the one object of $\mathbb{1}$, then G sends \emptyset to c in C . Since, in $E = \mathbb{1}$, $k = 1_{\mathbb{1}}$, then k can only send \emptyset to \emptyset . So the objects in the comma construction are rendered as pairs, with the relevant data c and f , represented as $(d \in C, f: d \rightarrow c)$.

Letting the morphism h take d to d' , while the morphism $k = 1_{\mathbb{1}}$ sends \emptyset to \emptyset , we have a codomain of the comma morphism (h, k) represented as $(d' \in C, f': d' \rightarrow c)$. This is a class of morphisms of C taken as objects, and the comma category is reduced to the C/c slice category. \square

EXERCISE 1.3.viii. Lemma 1.3.8 shows that functors preserve isomorphisms. Find an example to demonstrate that functors need not **reflect isomorphisms**: that is, find a functor $F: C \rightarrow D$ and a morphism f in C so that Ff is an isomorphism in D but f is not an isomorphism in C .

Consider the functor $F: \mathbb{2} \rightarrow \mathbb{1}$ that maps everything in $\mathbb{2}$ to the identity in $\mathbb{1}$. So F trivially satisfies all the properties of a functor. Because $\mathbb{2}$ is not a groupoid there exists at least one morphism f in $\text{mor } \mathbb{2}$ that is not an isomorphism. In this construction Ff will also go to the best isomorphism, the identity map, even though f itself is not an isomorphism.

EXERCISE 1.3.ix. For any group G , we may define other groups:

- the **center** $Z(G) = \{h \in G \mid hg = gh \forall g \in G\}$
- the **commutator subgroup** $C(G)$, the subgroup generated by the element $ghg^{-1}h^{-1}$ for any $g, h \in G$, and
- the **automorphism group** $\text{Aut}(G)$, the group of isomorphisms $\phi: G \rightarrow G$ in Group .

Trivially, all three constructions define a functor from the discrete category of groups (with only identity morphisms) to Group . Are these constructions functorial in

- the isomorphisms of groups? That is, do they extend to functors $\text{Group}_{\text{iso}} \rightarrow \text{Group}$?
- the epimorphisms of groups? That is, do they extend to functors $\text{Group}_{\text{epi}} \rightarrow \text{Group}$?
- the homomorphisms of groups? That is, do they extend to functors $\text{Group} \rightarrow \text{Group}$?

PROOF. First, consider the functor $F_Z : \text{Group}_{\text{id}} \rightarrow \text{Group}$, where $G \rightarrow Z(G)$. We will now show that there exists a similar functor $F_Z : \text{Group}_{\text{epi}} \rightarrow \text{Group}$. We define F_Z as the following: $F_Z(G) = Z(G)$ and if $f : G \rightarrow H$, then $F_Z f = f|_{Z(G)}$. We must show that this functor satisfies the properties of a functor.

1. Because each group has a unique center and each morphism f with $\text{dom}(f) = G$ has a unique restriction to $Z(G)$, this functor is well defined and satisfies the first two properties (0 and 1).
2. We see that $F_Z 1_G = 1_G|_{Z(G)} = 1_{Z(G)} = 1_{F_Z G}$, so the functor preserves identities.
3. We easily see that by definition of function restriction, if $f : G \rightarrow H$, then $\text{dom}(F_Z f) = F_Z \text{dom}(f)$. We choose $\text{cod}(F_Z f) = Z(H) = F_Z(\text{cod}(f))$. To see that our morphisms are still well-defined from when the domain and codomain are restricted by this functor, we show that if $g \in Z(G)$, then $f(g) \in Z(H)$. To do this, consider, for any $k \in H$, that since f is an epimorphism and therefore surjective, that $k = f(h)$ for some $h \in G$, so

$$f(g)k = f(g)f(h) = f(gh).$$

Since $g \in Z(G)$,

$$f(gh) = f(hg) = f(h)f(g) = kf(g)$$

So $f(g) \in Z(H)$ and therefore we have a well-defined morphism from $F_Z G$ to $F_Z H$.

4. If $f : G \rightarrow H$ and $g : H \rightarrow K$, we see that $F_Z(gf) = gf|_{Z(G)}$. By the property we proved in the previous part

$$gf|_{Z(G)} = g|_{Z(H)}f|_{Z(G)} = F_Z g F_Z f.$$

So this functor also preserves morphism composition.

We have seen that F_Z satisfies all properties of a functor. We also note that F_Z will be a functor from $\text{Group}_{\text{iso}} \rightarrow \text{Group}$.

To show that there is no such functor between Group and Group , consider the composition of the homomorphism $\text{sgn} : S_n \rightarrow \{\pm 1\}$ and $\iota : \{1, (1\ 2)\} \rightarrow S_4$. We say $g(x) = \text{sgn}(\iota(x))$. We see that g is an isomorphism, and so $F_Z g$ should also be an isomorphism. However, this is not possible under any function of morphism, as S_4 has a trivial center and so any morphism from $Z(\{1, (1\ 2)\}) \rightarrow Z(S_4) \rightarrow Z(\{\pm 1\})$ must be trivial. So F_Z cannot be a functor from $\text{Group} \rightarrow \text{Group}$.

Now consider the functor $F_C : \text{Group}_{\text{id}} \rightarrow \text{Group}$. We will show there exists a similarly constructed functor from $\text{Group} \rightarrow \text{Group}$ defined as the following: for $G \in \text{ob}(\text{Group})$, $F_C G = C(G)$, where $C(G)$ is the commutator subgroup of G . If $f : G \rightarrow H$, $F_C f = f|_{C(G)}$. We will show that this satisfies all the properties of a functor.

1. Because each group has a unique commutator subgroup and each morphism f with $\text{dom}(f) = G$ has a unique restriction to $C(G)$, this functor is well defined and satisfies the first two properties (0 and 1).
2. We see that $F_C 1_G = 1_G|_{C(G)} = 1_{C(G)} = 1_{F_C G}$, so the functor preserves identities.
3. We easily see that by definition of function restriction, if $f : G \rightarrow H$, then $\text{dom}(F_C f) = F_C \text{dom}(f)$. We choose $\text{cod}(F_C f) = C(H) = F_C(\text{cod}(f))$. To see that our morphisms are well defined when we restrict the domain and codomain, we show that if $g \in C(G)$, then $f(g) \in C(H)$. If $g \in C(G)$, $g = \prod_{i=1}^n a_i$, where each $a_i = hkh^{-1}k^{-1}$

for some $h, k \in G$. So

$$\begin{aligned}
f(g) &= f\left(\prod_{i=1}^n h_i k_i h_i^{-1} k_i^{-1}\right) \\
&= \prod_{i=1}^n f\left(h_i k_i h_i^{-1} k_i^{-1}\right) \\
&= \prod_{i=1}^n f(h_i) f(k_i) f(h_i^{-1}) f(k_i^{-1}) \\
&= \prod_{i=1}^n f(h_i) f(k_i) f(h_i)^{-1} f(k_i)^{-1}
\end{aligned}$$

But since $f(k_i), f(h_i) \in H$, this is an element of $C(H)$. So if $g \in C(G)$, $f(G) \in C(H)$ and therefore we have well-defined morphisms from our restricted domain to our restricted co-domain.

4. If $f: G \rightarrow H$ and $g: H \rightarrow K$, we see that $F_C(gf) = gf|_{C(G)}$. By the property we proved in the previous part

$$gf|_{C(G)} = g|_{C(H)} f|_{C(G)} = F_C g F_C f.$$

So this functor also preserves morphism composition.

So we have shown that this is a functor for $\text{Group} \rightarrow \text{Group}$, and we note that this implies that it is also a functor for $\text{Group}_{\text{iso}} \rightarrow \text{Group}$ and $\text{Group}_{\text{epi}} \rightarrow \text{Group}$.

Next, we show that there is a functor $F_A: \text{Group}_{\text{iso}} \rightarrow \text{Group}$, defined as follows: If G is a group, then $F_A G = \text{Aut}(G)$ and if ϕ is a morphism between two groups G and H , then $(F_A \phi)(f) = \phi f \phi^{-1}$. We now show that this definition satisfies the properties of a functor.

1. Each group has uniquely defined automorphism group, and each morphism ϕ conjugates elements of $\text{Aut}(G)$ in a unique way, so the functor is well defined.
2. $F_A(1_G)(f) = 1 f 1 = 1_{\text{Aut}(G)}(f)$, so the functor preserves identities.
3. $F_A(\text{dom } \phi) = F_A(G) = \text{Aut}(G) = \text{dom } F_A(\phi)$.
4. By definition of F_A , $\text{cod}(F_A \phi) = \text{Aut}(H) = F_A(\text{cod}(\phi))$. We see that $\phi f \phi^{-1} \in \text{Aut}(H)$ for any $f \in \text{Aut}(G)$ because it is a composition of isomorphisms and therefore also an isomorphism. So when we restrict the domain and codomain of our morphisms using this functor, then they are still well-defined.
5. For two composable morphisms ϕ and τ ,

$$F_A(\phi\tau)(f) = \phi\tau f(\phi\tau)^{-1} = \phi\tau f\tau^{-1}\phi^{-1} = F_A(\phi)(\tau f\tau^{-1}) = F_A(\phi)F_A(\tau)(f),$$

so this functor preserves composition.

So F_A satisfies all the properties of a functor, and there exists a functor from $\text{Group}_{\text{iso}} \rightarrow \text{Group}$ of the desired form.

It is unclear whether or not there is a functor from $\text{Group}_{\text{epi}}$ to Group and from Group to Group defined in the manner, but I believe that this is not the case, although I am having trouble finding a counterexample. \square

EXERCISE 1.3.x. Show that the construction of the set of conjugacy classes of elements of a group is functorial, defining a functor $\text{Conj}: \text{Group} \rightarrow \text{Set}$. Conclude that any pair of groups whose sets of conjugacy classes of elements have differing cardinalities cannot be isomorphic.

PROOF. Let the functor $\text{Conj}: \text{Group} \rightarrow \text{Set}$ represent the construction of the set of conjugacy classes of elements of a group, defined as follows:

- For any group s , $\text{Conj } s = \hat{s}$.
- For any groups s and t and any group homomorphism $f: s \rightarrow t$, define the morphism $\text{Conj } f: \hat{s} \rightarrow \hat{t}$ such that for each $[x] \in \hat{s}$, $\text{Conj } f([x]) = [f(x)]$.⁵

First we will prove that Conj is functorial by showing that it fulfills both functoriality axioms:

- Let f and g be group homomorphisms such that gf is a valid composition, and let $[x] \in (\text{dom}(f))^*$ be arbitrary.

$$\text{Conj } g \text{ Conj } f([x]) = \text{Conj } g([f(x)]) = [g(f(x))] = [gf(x)] = \text{Conj}(gf([x])).$$

Since $[x]$, f , and g were arbitrary, $\text{Conj } g \text{ Conj } f = \text{Conj}(gf)$. So Conj fulfills the first functoriality axiom.

- For an arbitrary group s and element $x \in s$,

$$\text{Conj } 1_s([x]) = [1_s(x)] = [x] = 1_{\hat{s}}([x]) = 1_{\text{Conj } s}([x]).$$

Since s and x were arbitrary, $\text{Conj } 1_s = 1_{\text{Conj } s}$. So Conj fulfills the second functoriality axiom.

Conj fulfills both axioms, so we can conclude that it is indeed functorial.

Let s and t be two isomorphic groups, and let $f: s \rightarrow t$ be an isomorphism. Functors preserve isomorphisms, (as per the ‘first lemma in category theory’) so $\text{Conj } f: \hat{s} \rightarrow \hat{t}$ must also be an isomorphism. This makes \hat{s} and \hat{t} isomorphic, which in turn means they must have the same cardinality. So we can conclude the contrapositive: that any pair of groups whose sets of conjugacy classes have *different* cardinalities *cannot* be isomorphic.

⁵In order for each $\text{Conj } f$ to be well-defined, it must send each $[x] \in \hat{s}$ to a single $[f(x)] \in \hat{t}$. But there may be more than one element in $[x]$, and since the definition does not mention which x should be used as a ‘representative,’ it might seem that there could be cases in which there were multiple possible $[f(x)]$ (and therefore, multiple possible $\text{Conj } f([x])$) for a single $[x]$. So in order for $\text{Conj } f$ to be well-defined, $[f(x)]$ must be the same for every possible choice of $x \in [x]$. In other words, we need to show that $[f(a)] = [f(b)]$ for any a, b in the same conjugate class.

So, let a, b be arbitrary members of the same conjugate class. Recall that this means that there is some $n \in s$ such that $b = nan^{-1}$. Furthermore, recall that group homomorphisms (like f) preserve inverses. With this in mind,

$$f(b) = f(nan^{-1}) = f(n)f(a)f(n^{-1}) = f(n)f(a)f(n)^{-1}$$

$n \in s$, so $f(n) \in t$. This means that there is some $m \in t$ such that $mf(a)m^{-1} = f(b)$. So $f(a)$ and $f(b)$ are conjugates, (and therefore $[f(a)] = [f(b)]$ by definition,) which makes $\text{Conj } f$ well-defined.

1.4 Naturality

EXERCISE 1.4.i. Suppose $\alpha : F \Rightarrow G$ is a natural isomorphism. Show that inverses of the component morphisms define the components of a natural isomorphism $\alpha^{-1} : G \Rightarrow F$.

PROOF. Suppose we have a natural isomorphism $\alpha : F \Rightarrow G$. We display the square of morphisms below for convenience.

$$\begin{array}{ccc} Fc & \xrightarrow{\alpha_c} & Gc \\ Ff \downarrow & & \downarrow Gf \\ Fc' & \xrightarrow{\alpha_{c'}} & Gc' \end{array}$$

The above diagram commutes, and $(Gf)(\alpha_c) = (\alpha_{c'})(Ff)$ takes us from Fc To Gc' . Consider the component morphisms α_c of α . Because α is a natural isomorphism, every component morphism, α_c , has an inverse, α_c^{-1} . We need to see that all the inverse component morphisms, α_c^{-1} , make a natural transformation.

To see where α_c^{-1} takes us, examine the square of morphisms below. All the components are still in D and take us from Gc to Fc' .

$$\begin{array}{ccc} Gc & \xrightarrow{\alpha_c^{-1}} & Fc \\ Gf \downarrow & & \downarrow Ff \\ Gc' & \xrightarrow{\alpha_{c'}^{-1}} & Fc' \end{array}$$

Since $(Gf)\alpha_c = \alpha_{c'}(Ff)$,

$$\alpha_{c'}^{-1}(Gf) = \alpha_{c'}^{-1}(Gf)\alpha_c\alpha_c^{-1} = \alpha_{c'}^{-1}\alpha_{c'}(Ff)\alpha_c^{-1} = (Ff)\alpha_c^{-1}.$$

So, the diagram above commutes and if we let $(\alpha^{-1})_c = \alpha_c^{-1}$ then α^{-1} is a natural transformation from G to F . □

EXERCISE 1.4.ii. What is a natural transformation between a parallel pair of functors between groups, regarded as one-object categories?

PROOF. For the abstract, one-object categories that are defined by groups, we can take any single object C_* and D_* as the special objects of the respective groups. We then have the class of morphisms as the elements of the groups under their respective group operations. Let the operations here be group multiplication. We will start by finding what the functors are between these categories, and then find natural transformation in this context.

Given two such categories, BC and BD with their respective groups C and D , any functors F and G between BC and BD must map the object C_* to the object D_* . Since

functors are functions, looking at the functor F , the role of F acting on the morphisms of BC is the same as a function acting on the elements of C under group multiplication. So, $F : C_* \rightarrow D_*$, for the special elements $C_* \in BC$ and $D_* \in BD$. Taking any two elements c, c' in C , cc' is the composition in the category BC , and since the both the domain codomain of BC are equal to C , then any pair cc' is composable. As functors respect the functoriality axioms, $F(cc') = F(c)F(c')$ in D , and $F(1_C) = 1_{F_C}$ in D , then the functor F behaves as a group homomorphism between the groups C and D .

To find a natural transformation $\alpha : F \Rightarrow G$ between F and G , we can let $\alpha_{C_*} : FC_* \rightarrow GC_*$ be a class of morphisms, with $f : C_* \rightarrow C_*$, such that $Gf\alpha_{C_*} = \alpha_{C_*}Ff$. In our case, we have C_* as the single object of BC , and the morphism f as an element c in C . Also, we have that $FC_* = D_*$ and $GC_* = D_*$, so our morphism is now $\alpha_{C_*} : D_* \rightarrow D_*$. Thus, for the object C_* , the natural transformation gives the equality $\alpha_{C_*}Ff = Gf\alpha_{C_*}$.

Since α_{C_*} is a morphism from the object D_* to itself, this endomorphism (and hence automorphism) consists of the elements of the group D . Because each element has an inverse, likewise α_{C_*} has an inverse, $\alpha_{C_*}^{-1}$. Thus $\alpha_{C_*}Ff = Gf\alpha_{C_*}$ implies $\alpha_{C_*}^{-1}\alpha_{C_*}Ff = \alpha_{C_*}^{-1}Gf\alpha_{C_*}$, implies $Ff = \alpha_{C_*}^{-1}Gf\alpha_{C_*}$, for all f . Noting that Ff and Gf are morphisms in the category BD , and hence is an element of the group D , then Ff and Gf are in $\text{Aut}(D)$, and α_{C_*} forms a conjugacy class for these automorphisms. \square

EXERCISE 1.4.iii. What is a natural transformation between a parallel pair of functors between preorders, regarded as categories?

PROOF. Let C and D be preorder categories and $F, G : C \rightrightarrows D$ be parallel functors. Let us consider the properties of the natural transformation $\alpha : F \rightarrow G$. We will show that you need only find morphisms $f_c : Fc \rightarrow Gc$ in D for all $c \in \text{ob } C$ to produce a natural transformation from F to G . This will assist in our characterization of natural transformations.

Suppose we have morphisms $f_c : Fc \rightarrow Gc$ in D for $c \in \text{ob } C$. We can define $\alpha : F \rightarrow G$ such that $\alpha(c) = f_c$. Take morphism $g : c \rightarrow c'$ in D , we have that the diagram

$$\begin{array}{ccc} Fc & \xrightarrow{Fg} & Fc' \\ \alpha(c) \downarrow & & \downarrow \alpha(c') \\ Gc & \xrightarrow{Gg} & Gc' \end{array}$$

commutes since in a preorder category, there is at most one morphism between objects. Thus, our α defines a natural transformation from F to G . Thus it is sufficient to find morphisms $f_c : Fc \rightarrow Gc$ in D to define a natural transformation from F to G .

Seeing the functors F and G as monotone maps (i.e. order preserving maps) between preorders C to D , this allows us to characterize a natural transformation α as a relation over D containing only the pairs (Fc, Gc) . \square

EXERCISE 1.4.iv. In the notation of Example 1.4.7, prove that distinct parallel morphisms $f, g: c \rightrightarrows d$ define distinct natural transformations

$$\begin{aligned} f_*, g_* &: \mathbf{C}(-, c) \rightrightarrows \mathbf{C}(d, -) \\ f^*, g^* &: \mathbf{C}(c, -) \rightrightarrows \mathbf{C}(d, -) \end{aligned}$$

PROOF. These being natural transformations is shown in Example 1.4.7, so the primary concern of this problem is whether they are distinct. First, we consider f_*, g_* as natural transformations from $\mathbf{C}(-, c) \rightrightarrows \mathbf{C}(-, d)$. To differentiate, consider the natural transformation defined by f_* to be α and g_* to be β . We need to show the transformations are different in at least some component. For a natural transformation, we can choose arbitrary $h: c_1 \rightarrow c_2$ in \mathbf{C} to look at the functions for. In this case, take $h = 1_c$. We thus in our diagram have h^* as our Fh and Gh , which is precomposition by 1_c . This must be the case as a functor preserves identities. We then consider what this transformation does to the morphism $j = 1_c \in \mathbf{C}(c, c)$ to see what would happen to it if we put it through the transformation. Both directions take us to $fj1_c = fj = f$. Similarly, constructing the same diagram except with g , we get $gj1_c = gj = g$. Each takes us to a different morphism in $\mathbf{C}(c, d)$ and thus the two transformations are different. Essentially the same construction works with f^* and g^* .

$$\begin{array}{ccc} \mathbf{C}(c, c) & \xrightarrow{1_c^*} & \mathbf{C}(c, c) \\ f_* \downarrow & & \downarrow f_* \\ \mathbf{C}(c, d) & \xrightarrow{1_c^*} & \mathbf{C}(c, d) \end{array}$$

EXERCISE 1.4.v. Recall the construction of the comma category for any pair of functors $F: \mathbf{D} \rightarrow \mathbf{C}$ and $G: \mathbf{E} \rightarrow \mathbf{C}$ described in Exercise 1.3.vi. From this data, construct a canonical natural transformation $\alpha: F \text{ dom} \rightrightarrows G \text{ cod}$ between the functors that form the boundary of the square

$$\begin{array}{ccc} F \downarrow G & \xrightarrow{\text{cod}} & E \\ \text{dom} \downarrow & \nearrow \alpha & \downarrow G \\ D & \xrightarrow{F} & C \end{array}$$

PROOF. Letting $c = (d, e, f: d \rightarrow e \in C)$ as above, and a morphism $m = (h: d \rightarrow d', k: e \rightarrow e')$, we can describe the actions of the functors $F \text{ dom}$ and $G \text{ cod}$ on objects:

- $F \text{ dom } c = Fd$,
- $G \text{ cod } c = Ge$,

and their actions on morphisms:

- $F \text{ dom } m = Fh$,

- $G \text{ cod } m = Gk$.

From the definition of a natural transformation, we need an $\alpha : \text{ob } F \downarrow G \rightarrow \text{mor } \mathbf{C}$, and we can get this by taking $(d, e, f) \mapsto f \in \mathbf{C}$. Then, $\alpha_c : Fd \rightarrow Ge$ in \mathbf{C} . From this, we can construct the following diagram:

$$\begin{array}{ccc} Fd & \xrightarrow{\alpha_c} & Ge \\ Fh \downarrow & & \downarrow Gk \\ Fd' & \xrightarrow{\alpha_{c'}} & Ge' \end{array}$$

Which is precisely the diagram of the comma category with $f = \alpha_c$ and $f' = \alpha_{c'}$, and from the condition that $f'Fh = Gkf$, we have that this diagram commutes. Thus, α is a natural transformation. \square

EXERCISE 1.4.vi. Given a pair of functors $F : \mathbf{A} \times \mathbf{B} \times \mathbf{B}^{\text{op}} \rightarrow \mathbf{D}$ and $G : \mathbf{A} \times \mathbf{C} \times \mathbf{C}^{\text{op}} \rightarrow \mathbf{D}$ a family of morphisms

$$\alpha_{a,b,c} : F(a, b, b) \rightarrow G(a, c, c)$$

in \mathbf{D} defines the components of an **extranatural transformation** $\alpha : F \Rightarrow G$ if for any $f : a \rightarrow a'$, $g : b \rightarrow b'$, and $h : c \rightarrow c'$ the following diagrams commute in \mathbf{D} :

$$\begin{array}{ccccc} F(a, b, b) & \xrightarrow{\alpha_{a,b,c}} & G(a, c, c) & & F(a, b, b) & \xrightarrow{\alpha_{a,b,c'}} & G(a, c', c') \\ F(f, 1_b, 1_b) \downarrow & & \downarrow G(f, 1_c, 1_c) & & F(a, b, b) & \xrightarrow{F(1_a, 1_b, g)} & F(a, b, b) \\ F(a', b, b) & \xrightarrow{\alpha_{a',b,c}} & G(a', c, c) & & F(a, b, b') & \xrightarrow{\alpha_{a,b',c}} & G(a, c, c) \\ & & & & \downarrow F(1_a, g, 1_{b'}) & & \downarrow \alpha_{a,b,c} \\ & & & & F(a, b', b') & \xrightarrow{\alpha_{a,b',c}} & G(a, c, c) \\ & & & & & & \downarrow G(\alpha_{a,b,c}) \\ & & & & & & G(a, c, c) & \xrightarrow{G(1_a, h, 1_c)} & G(a, c', c) \\ & & & & & & & & \downarrow G(1_a, 1_{c'}, h) \end{array}$$

The left-hand square asserts that the components $\alpha_{-,b,b} : F(-, b, b) \Rightarrow G(-, c, c)$ define a natural transformation in a for each $b \in \mathbf{B}$ and $c \in \mathbf{C}$. The remaining squares assert that the components $\alpha_{a,-,-} : F(a, -, -) \Rightarrow G(a, c, c)$ and $\alpha_{a,b,-} : F(a, b, b) \Rightarrow G(a, -, -)$ define transformations that are respectively extranatural in b and in c . Explain why functors F and G must have a common target category for this definition to make sense.

Notice that the definition of extranatural transformation does not actually have anything to do with the question. This exercise is nothing more than a sanity check. If F and G do not have the same target category, when we try to write down any of the three above diagrams, we will see that they are simply not defined if F and G do not have the same target category.

1.5 Equivalence of categories

LEMMA 1.5.1. Fixing a parallel pair of functors $F, G : \mathbf{C} \rightrightarrows \mathbf{D}$, natural transformations $\alpha : F \Rightarrow G$ correspond bijectively to functors $H : \mathbf{C} \times \mathcal{2} \rightarrow \mathbf{D}$ such that H restricts along i_0 and i_1 to the functors F and G , i.e., so that

$$\begin{array}{ccccc}
 \mathbf{C} & \xrightarrow{i_0} & \mathbf{C} \times \mathcal{2} & \xleftarrow{i_1} & \mathbf{C} \\
 & \searrow F & \downarrow H & \swarrow G & \\
 & & \mathbf{D} & &
 \end{array}$$

Before going on, I'd like to make a set-theoretic remark about exactly what the bijection is between. Say that U is a non-empty universe and that \mathbf{C} and \mathbf{D} are U -categories.

Assume further that \mathbf{C} is a U -small category and that \mathbf{D} is a U -locally small category. Then the class of all morphisms from Fc to Gc as c varies over objects of \mathbf{C} forms a U -set. Then the class of all functions from $\text{ob } \mathbf{C}$ to this U -set is also a U -set. The natural transformations form a subclass of this U -set, and so the class of all natural transformations from F to G forms a U -set.

In this case, $\mathbf{C} \times \mathcal{2}$ is also a U -small category and so each functor $H : \mathbf{C} \times \mathcal{2} \rightarrow \mathbf{D}$ is a U -set by the Axiom of Replacement in U . We may thus form a U -class of these functors. The lemma then implies through the Axiom of Replacement again that this U -class is also a U -set.

However, if the objects of \mathbf{C} form a proper U -class, then any natural transformation $\alpha : F \Rightarrow G$ is also a proper U -class. This is because as a function, α has domain $\text{ob } \mathbf{C}$, a proper U -class. In this case, α is not an element of U and is thus not an element of any U -class.

In either case, let V be a universe such that $U \in V$. Then all of the categories mentioned in the lemma are small V -categories so that the bijection in the lemma is a bijection between V -sets.

EXERCISE 1.5.i. Prove the lemma above.

PROOF. In the category $\mathcal{2}$, there are precisely three morphisms:

$$\begin{aligned}
 \phi_{00} &: 0 \rightarrow 0 \\
 \phi_{01} &: 0 \rightarrow 1 \\
 \phi_{11} &: 1 \rightarrow 1
 \end{aligned}$$

(ϕ_{00} and ϕ_{11} are identity morphisms.) Any morphism in $\mathbf{C} \times \mathcal{2}$ is of the form

$$(f, \phi_{mn}) : (x, m) \rightarrow (y, n)$$

where $f : x \rightarrow y$ is a morphism in \mathbf{C} and $m, n \in \{0, 1\}$ with $m \leq n$.

Let N be the collection (or more precisely U -set or V -set as above) of natural transformations from F to G , and let X be the collection of functors H as described in the statement of the lemma. We first make a function from N to X taking $\alpha \in N$ to $H_\alpha \in X$.

Define the functor $H_\alpha : \mathbf{C} \times \mathcal{2} \rightarrow \mathbf{D}$ as follows:

1. For every $c \in \text{ob } \mathbf{C}$,
 - (a) $H_\alpha(c, 0) = Fc$ and
 - (b) $H_\alpha(c, 1) = Gc$.
2. For every morphism $f : x \rightarrow y$ in \mathbf{C} ,
 - (a) $H_\alpha(f, \phi_{00}) = Ff$,
 - (b) $H_\alpha(f, \phi_{11}) = Gf$, and
 - (c) $H_\alpha(f, \phi_{01}) = Gf\alpha_x = \alpha_y Ff$.

There is no ambiguity in the final case, since $\alpha : F \Rightarrow G$ being a natural transformation tells us that the following diagram commutes.

$$\begin{array}{ccc}
 Fx & \xrightarrow{Ff} & Fy \\
 \alpha_x \downarrow & & \downarrow \alpha_y \\
 Gx & \xrightarrow{Gf} & Gy
 \end{array}$$

Let's check that H really is a functor. It takes objects to objects and morphisms to morphisms. Notice that in each of the three formulas for $H_\alpha(f, \phi_{mn})$, the domain of $H_\alpha(f, \phi_{mn})$ is equal to $H_\alpha(x, m)$, either Fx or Gx as need be. Likewise, in each case the codomain of $H_\alpha(f, \phi_{mn})$ is equal to $H_\alpha(y, n)$, either Fy or Gy as need be. So, we see that $H_\alpha \circ \text{dom} = \text{dom} \circ H_\alpha$ and $H_\alpha \circ \text{cod} = \text{cod} \circ H_\alpha$ as required.

(f, ϕ_{mn}) is an identity if and only if $f = 1_x$ and $m = n$. We have that $H_\alpha(1_x, \phi_{00}) = F1_x = 1_{Fx}$, since F is a functor, and $H_\alpha(1_x, \phi_{11}) = G1_x = 1_{Gx}$, since G is a functor. So, H_α takes identities to identities as required.

Finally, if we also have $(g, \phi_{np}) : (y, n) \rightarrow (z, p)$ then $m \leq n \leq p$ and $(g, \phi_{np})(f, \phi_{mn}) = (gf, \phi_{mp})$. There are four cases to consider:

1. $(m, n, p) = (0, 0, 0)$:

$$H_\alpha(gf, \phi_{00}) = F(gf) = FgFf = H_\alpha(g, \phi_{00})H_\alpha(f, \phi_{00}).$$

2. $(m, n, p) = (0, 0, 1)$:

$$\begin{aligned}
 H_\alpha(gf, \phi_{01}) &= G(gf)\alpha_x = Gg(Gf\alpha_x) = Gg(\alpha_y Ff) \\
 &= (Gg\alpha_y)Ff = H_\alpha(g, \phi_{01})H_\alpha(f, \phi_{00}).
 \end{aligned}$$

3. $(m, n, p) = (0, 1, 1)$:

$$H_\alpha(gf, \phi_{01}) = G(gf)\alpha_x = Gg(Gf\alpha_x) = H_\alpha(g, \phi_{11})H_\alpha(f, \phi_{01}).$$

4. $(m, n, p) = (1, 1, 1)$:

$$H_\alpha(gf, \phi_{11}) = G(gf) = GgGf = H_\alpha(g, \phi_{11})H_\alpha(f, \phi_{11}).$$

Now, the functors $i_n : \mathbf{C} \rightarrow \mathbf{C} \times 2$ for $n = 0, 1$ are the following. On objects, $i_n c = (c, n)$. On morphisms, $i_n f = (f, \phi_{nn})$. So, on objects the compositions are $H_\alpha i_0 c = H_\alpha(c, 0) = Fc$ and $H_\alpha i_1 c = H_\alpha(c, 1) = Gc$. On morphisms, the compositions

are $H_{\alpha}i_0f = H_{\alpha}(f, \phi_{00}) = Ff$ and $H_{\alpha}i_1f = H_{\alpha}(f, \phi_{11}) = Gf$. So, $H_{\alpha}i_0 = F$ and $H_{\alpha}i_1 = G$ as required. So, we have constructed a function $\alpha \mapsto H_{\alpha}$ from N to X .

Now, we construct a function from X to N . Given a functor $H : \mathbf{C} \times \mathcal{2} \rightarrow \mathbf{D}$ such that $Hi_0 = F$ and $Hi_1 = G$, we must construct a natural transformation $\alpha^H : F \Rightarrow G$. For an object c in \mathbf{C} , let $\alpha_c^H = H(1_c, \phi_{01})$. We must see that this gives a natural transformation.

Using that H is a functor, we have that

$$\text{dom } \alpha_c^H = \text{dom } H(1_c, \phi_{01}) = H \text{ dom}(1_c, \phi_{01}) = H(c, 0) = Fc.$$

Similarly,

$$\text{cod } \alpha_c^H = \text{cod } H(1_c, \phi_{01}) = H \text{ cod}(1_c, \phi_{01}) = H(c, 1) = Gc.$$

So, $\alpha_c^H : Fc \rightarrow Gc$ as required.

Now, if $f : x \rightarrow y$ in \mathbf{C} , then

$$\begin{aligned} Gf\alpha_x^H &= H(i_1f)H(1_x, \phi_{01}) = H(f, \phi_{11})H(1_x, \phi_{01}) = H(f, \phi_{01}) \\ &= H(1_y, \phi_{01})H(f, \phi_{00}) = \alpha_y^H H(i_0f) = \alpha_y^H Ff. \end{aligned}$$

This verifies that α^H is a natural transformation from F to G , so that we have constructed a function from X to N taking H to α^H .

Now, we must see that our two functions are inverses of each other. Starting with a natural transformation α in N , going to X and back to N gives the natural transformation $\alpha^{H\alpha}$. For each object c in \mathbf{C} , we must verify that $\alpha_c^{H\alpha} = \alpha_c$. Combining the definitions of our two functions, we see that

$$\alpha_c^{H\alpha} = H_{\alpha}(1_c, \phi_{01}) = G1_c\alpha_c = 1_{Gc}\alpha_c = \alpha_c$$

as required.

In the other direction, we must verify that for any $H \in X$, $H_{\alpha^H} = H$. On objects, $H_{\alpha^H}(x, 0) = Fx = Hi_0x = H(x, 0)$ and $H_{\alpha^H}(x, 1) = Gx = Hi_1x = H(x, 1)$. So, these two functors agree on objects.

On morphisms, we have three cases for a given $f : x \rightarrow y$ in \mathbf{C} .

1.

$$H_{\alpha^H}(f, \phi_{00}) = Ff = Hi_0f = H(f, \phi_{00}),$$

2.

$$H_{\alpha^H}(f, \phi_{11}) = Gf = Hi_1f = H(f, \phi_{11}),$$

3.

$$H_{\alpha^H}(f, \phi_{01}) = Gf\alpha_x^H = Hi_1f\alpha_x^H = H(f, \phi_{11})H(1_x, \phi_{01}) = H(f, \phi_{01}).$$

So, H and H_{α^H} agree on morphisms as well as objects, so that $H = H_{\alpha^H}$ as required. \square

EXERCISE 1.5.ii. Segal defined a category Γ as follows:

Γ is the category whose objects are all finite sets, and whose morphisms from S to T are the maps $\theta: S \rightarrow P(T)$ such that $\theta(\alpha)$ and $\theta(\beta)$ are disjoint when $\alpha \neq \beta$. The composite of $\theta: S \rightarrow P(T)$ and $\phi: T \rightarrow P(U)$ is $\psi: S \rightarrow P(U)$, where $\psi(\alpha) = \bigcup_{\beta \in \theta(\alpha)} \phi(\beta)$.

Prove that Γ is equivalent to the opposite of the category Fin_* of finite pointed sets. In particular, the functors introduced in Example 1.3.2(xi) define presheaves on Γ .

PROOF. As a preliminary matter, it is worth checking that Γ is indeed a category. The definition above makes clear that an arrow $\theta: S \rightarrow P(T)$ has domain S and codomain T , as well as telling us how to compose two morphisms. What is less obvious is what morphisms are the identities, and that composition is associative. For identities, let us first note that the identity on S in Γ is a function $1_S: S \rightarrow P(S)$ meaning the usual identity on the set S is not a possibility. However, there is a natural embedding of S in $P(S)$ which takes every element α to the singleton $\{\alpha\}$. Checking composition of 1_S and 1_T thus defined with an arbitrary map $\theta: S \rightarrow P(T)$ gives:

$$\begin{aligned}\theta 1_S(\alpha) &= \bigcup_{\beta \in 1_S(\alpha)} \theta(\beta) = \bigcup_{\beta \in \{\alpha\}} \theta(\beta) = \theta(\alpha) \\ 1_T \theta(\alpha) &= \bigcup_{\beta \in \theta(\alpha)} 1_T(\beta) = \bigcup_{\beta \in \theta(\alpha)} \{\beta\} = \theta(\alpha)\end{aligned}$$

verifying that we have defined the identities properly. Finally, we have to check that the composition law is associative. Let θ be as above along with $\phi: T \rightarrow P(U)$ and $\psi: U \rightarrow P(V)$ be valid morphisms in Γ . Then

$$((\psi\phi)\theta)(\alpha) = \bigcup_{\beta \in \theta(\alpha)} \phi\psi(\beta) = \bigcup_{\beta \in \theta(\alpha)} \left(\bigcup_{\gamma \in \phi(\beta)} \psi(\gamma) \right),$$

and

$$(\psi(\phi\theta))(\alpha) = \bigcup_{\gamma \in \phi\theta(\alpha)} \psi(\gamma) = \bigcup_{\gamma \in \left(\bigcup_{\beta \in \theta(\alpha)} \phi(\beta) \right)} \psi(\gamma).$$

At first appearance it is not at all clear that these ought to be the same set, but unpacking makes it clear they are in fact the same. Both assert that for any $\delta \in (\psi(\phi\theta))$ there exists some $\beta \in \theta(\alpha)$ and $\gamma \in \phi(\beta)$ such that $\delta \in \psi(\gamma)$. Thus our composition law is associative and we have indeed defined a category.

An equivalence of categories consists of two functors along with two natural isomorphisms between their compositions and the identity functor on each category. We will

thus begin by defining two functors $+: \Gamma \rightleftarrows \text{Fin}_*^{\text{op}} : (-)^{-1}$. We define $+$ by the following mappings:

$$\begin{aligned} S &\mapsto (S \cup \{S\}, S) \\ \theta: S \rightarrow T &\mapsto +\theta: +T \rightarrow +S \end{aligned}$$

where

$$+\theta(\beta) = \begin{cases} S & \text{if } \beta = T \\ S & \text{if } \beta \notin \bigcup_{\alpha \in S} \theta(\alpha) \\ \alpha \in S & \text{if } \beta \in \theta(\alpha) \end{cases}.$$

Note first that this is a valid map from $+T$ to $+S$ in Fin_* (and thus a map from $+S$ to $+T$ in Fin_*^{op}): it takes the base point of $+T$ to the base point of $+S$, if $\alpha \in \theta(\gamma)$ for some $\gamma \in S$, then this γ must be unique since the image of distinct elements of S under θ must be disjoint. We must further check the functoriality axioms. Recall that the identity map on an object S of Γ is $1_S: \alpha \mapsto \{ \alpha \}$. Applying this to the definition above gives:

$$+1_S(\alpha) = \begin{cases} S & \text{if } \alpha = S \\ S & \text{if } \alpha \notin \bigcup_{\alpha' \in S} 1_S(\alpha') = S, \\ \alpha' \in S & \text{if } \alpha \in 1_S(\alpha') = \{ \alpha' \} \end{cases}, \quad \text{which is clearly the identity.}$$

So $+1_S = 1_{+S}$.

Further, given morphisms $\theta: S \rightarrow T$ and $\phi: T \rightarrow U$ between objects of Γ , we have that

$$+\phi(\gamma) = \begin{cases} T & \text{if } \gamma = U \\ T & \text{if } \gamma \notin \bigcup_{\beta \in T} \phi(\beta), \\ \beta \in T & \text{if } \gamma \in \phi(\beta) \end{cases}, \quad +\theta(\beta) = \begin{cases} S & \text{if } \beta = T \\ S & \text{if } \beta \notin \bigcup_{\alpha \in S} \theta(\alpha), \\ \alpha \in S & \text{if } \beta \in \theta(\alpha) \end{cases},$$

$$\text{and } +\phi\theta(\gamma) = \begin{cases} S & \text{if } \gamma = U \\ S & \text{if } \gamma \notin \bigcup_{\alpha \in S} \phi\theta(\alpha) = \bigcup_{\alpha \in S} \bigcup_{\beta \in \theta(\alpha)} \phi(\beta) \\ \alpha \in S & \text{if } \gamma \in \phi\theta(\alpha) = \bigcup_{\beta \in \theta(\alpha)} \phi(\beta) \end{cases}.$$

Letting $\gamma \in +U$ be arbitrary there are several cases. First, if $\gamma = U$, then $+\phi\theta(\gamma) = S$ and $+\phi(\gamma) = T$ so $+\theta + \phi(\gamma) = S$. Alternately, if $\gamma \neq U$ so $\gamma \in U$ we again have two cases. If there exists $\alpha \in S$ such that $\gamma \in \phi\theta(\alpha)$, then $+\phi\theta(\gamma) = \alpha$ and there exists a $\beta \in \theta(\alpha)$ such that $\gamma \in \phi(\beta)$ implying $+\phi(\gamma) = \beta$ and $+\theta(\beta) = \alpha$ so $+\theta + \phi(\gamma) = \alpha$. Finally, if there exists no such $\alpha \in S$, then $+\phi\theta(\gamma) = S$. If there also exists no $\beta \in T$ such that $\gamma \in \phi(\beta)$ then $+\phi(\gamma) = T$ so $+\theta + \phi(\gamma) = S$. However, if such $\beta \in T$ does exist so that $+\phi(\gamma) = \beta$ then it must be the case that

Next we define the functor $(-)^{-1}$ by:

$$\begin{aligned} (S, s) &\mapsto S \setminus \{s\} \\ f: (T, t) \rightarrow (S, s) &\mapsto f^{-1}: S \setminus \{s\} \rightarrow T \setminus \{t\} \end{aligned}$$

where

$$f^{-1}(\alpha) = \{ \beta \in T \mid f(\beta) = \alpha \}.$$

Note that if $f^{-1}(\alpha) \cap f^{-1}(\alpha')$ is inhabited, then there is some $\beta \in T$ such that $f(\beta) = \alpha$ and $f(\beta) = \alpha'$ implying that $\alpha = \alpha'$. Thus the map we have defined satisfies the disjointness condition sufficient to be an morphism in Γ . Again we must check functoriality axioms. The identity morphism on (S, s) is merely the identity function on S , so

$$\begin{aligned} 1_S^{-1}(\alpha) &= \{ \alpha' \in S \mid 1_S(\alpha') = \alpha \} \\ &= \{ \alpha' \in S \mid \alpha' = \alpha \} = \{ \alpha \} = 1_{(-)^{-1}S}(\alpha). \end{aligned}$$

Given morphisms $f: (T, t) \rightarrow (S, s)$ and $g: (U, u) \rightarrow (T, t)$ we have that

$$\begin{aligned} (fg)^{-1}(\alpha) &= \{ \gamma \in U \mid fg(\gamma) = \alpha \} \\ &= \bigcup_{f(\beta)=\alpha} \{ \gamma \in U \mid g(\gamma) = \beta \} \\ &= \bigcup_{\beta \in f^{-1}(\alpha)} g^{-1}(\beta) = g^{-1}f^{-1}(\alpha). \end{aligned}$$

We thus have two bona fide functors connecting Γ and Fin_*^{op} . What remains is to construct natural isomorphisms $\eta: 1_\Gamma \cong (-)^{-1}+$ and $\epsilon: +(-)^{-1} \cong 1_{\text{Fin}_*^{\text{op}}}$. Looking first at η , given an object S of Γ we have that

$$(-)^{-1} + S = (-)^{-1}(S \cup \{ S \}, S) = (S \cup \{ S \}) \setminus \{ S \} = S$$

meaning that the collection of maps which make up η will be automorphisms. Further, given $\theta: S \rightarrow T$ and $\alpha \in (-)^{-1} + S = S$, we have

$$(-)^{-1} + \theta(\alpha) = \{ \beta \in T \mid +\theta(\beta) = \alpha \}.$$

Now, recall that $+\theta(\beta) = \alpha$ precisely when $\beta \in \theta(\alpha)$ and thus

$$\{ \beta \in T \mid +\theta(\beta) = \alpha \} = \theta(\alpha)$$

so that $(-)^{-1}+$ is the identity functor on Γ and we may take our natural isomorphism to be the collection of identity maps 1_S for each object S of Γ .

Now for ϵ , given an object (S, s) of Fin_*^{op} we have that

$$+(-)^{-1}(S, s) = +S \setminus \{ s \} = ((S \setminus \{ s \}) \cup \{ S \setminus \{ s \} \}, S \setminus \{ s \})$$

For sanity's sake we will use the notation $(S_* \cup \{ S_* \}, S_*)$ for the above set. This grotesque looking object (which amounts to replacing s with something more generic) is not S . However, there is a based isomorphism ϵ_s from S to it which takes s to $S \setminus \{ s \}$ and leaves the other elements of S be. The collection of such isomorphisms will form ϵ . Similarly, given a map $f: (T, t) \rightarrow (S, s)$ we have that

$$+(f^{-1})(\beta) = \begin{cases} S_* & \text{if } \beta = T_* \\ S_* & \text{if } \beta \notin \bigcup_{\alpha \in S_*} f^{-1}(\alpha) = \bigcup_{\alpha \in S_*} \{ \beta \in T \mid f(\beta) = \alpha \} . \\ \alpha \in S_* & \text{if } \beta \in f^{-1}(\alpha) = \{ \beta \in T \mid f(\beta) = \alpha \} \end{cases}$$

To verify that these do constitute a natural isomorphism we must check that the following diagram commutes:

$$\begin{array}{ccc} (S, s) & \xleftarrow{f} & (T, t) \\ \epsilon_S \downarrow & & \downarrow \epsilon_T \\ S_* & \xleftarrow{+(f^{-1})} & T_* \end{array}$$

Let β be an element of T, t , there are two cases to consider. If $\beta = t$, then

$$\epsilon_S f(t) = \epsilon_S(s) = S_* \quad \text{and} \quad +(f^{-1}) \epsilon_T(t) = +(f^{-1}) T_* = S_*.$$

If $\beta \neq t$, then either $f(\beta) = s$ or $f(\beta) \neq s$. In the first case, there is no element $\alpha \in S \setminus \{s\}$ such that $f(\beta) = \alpha$. Since β is not in any of the fibers from $S \setminus \{s\}$, by definition it is taken to S_* by $+(f^{-1})$, thus

$$\epsilon_S f(\beta) = \epsilon_S(s) = S_* \quad \text{and} \quad +(f^{-1}) \epsilon_T(\beta) = +(f^{-1})(\beta) = S_*.$$

Finally, in the interesting case where $f(\beta) \neq s$, we have $f(\beta) = \alpha$ for some $\alpha \in S \setminus \{s\}$, so $\beta \in f^{-1}(\alpha)$, and thus

$$\epsilon_S f(\beta) = \epsilon_S \alpha = \alpha \quad \text{and} \quad +(f^{-1}) \epsilon_T(\beta) = +(f^{-1})(\beta) = \alpha.$$

Thus we have defined a natural isomorphism and we may conclude that Γ is equivalent to Fin_*^{op} . □

EXERCISE 1.5.iii. Finish the following proof of Lemma 1.5.10:

LEMMA 1.5.10. Any morphism $f: a \rightarrow b$ and fixed isomorphisms $a \cong a'$ and $b \cong b'$ determine a unique morphism $f': a' \rightarrow b'$ so that any of—or, equivalently, all of—the following four diagrams commute:

$$\begin{array}{cccc} \begin{array}{ccc} a & \xleftarrow{\cong} & a' \\ f \downarrow & & \downarrow f' \\ b & \xrightarrow{\cong} & b' \end{array} & \begin{array}{ccc} a & \xrightarrow{\cong} & a' \\ f \downarrow & & \downarrow f' \\ b & \xrightarrow{\cong} & b' \end{array} & \begin{array}{ccc} a & \xleftarrow{\cong} & a' \\ f \downarrow & & \downarrow f' \\ b & \xleftarrow{\cong} & b' \end{array} & \begin{array}{ccc} a & \xrightarrow{\cong} & a' \\ f \downarrow & & \downarrow f' \\ b & \xleftarrow{\cong} & b' \end{array} \end{array}$$

For legibility, I use α to denote the isomorphism $\cong: a' \rightarrow a$ (with α^{-1} denoting its inverse) and β to denote the isomorphism $\cong: b' \rightarrow b$ (with β^{-1} denoting its inverse.) Furthermore, I refer to the first, second, third, and fourth diagrams, counting from the left.

PROOF. The prompt implies that the first diagram, at least, is commutative; so we know that $f' = \beta f \alpha$.

At this point, it might be tempting to immediately right-compose both sides of that expression with α^{-1} , to obtain $f'(\alpha^{-1}) = \beta f \alpha(\alpha^{-1})$. Then we could simplify to obtain $f' \alpha^{-1} = \beta f$, and *voilà!* The second diagram commutes! . . . Right?

Well, no, not quite. The logic above is missing a crucial step—it first assumes that we actually *can* right-compose both sides of $f' = \beta f \alpha$ with α^{-1} . It is true that since an isomorphism can always be composed with its inverse, the validity of the composition $\beta f \alpha(\alpha^{-1})$ is trivial. But the validity of $f'(\alpha^{-1})$ is decidedly non-trivial, and this must be proven before the logic above can be applied.

First, it will be useful to explicitly identify the domains and codomains of the morphisms included in each diagram, to make further references more concise. These can easily be inferred from the diagrams: $f: a \rightarrow b$; $f': a' \rightarrow b'$; $\alpha: a' \rightarrow a$; and $\beta: b \rightarrow b'$; while the inverses of each morphism go between the same objects, but with the domain and codomain reversed. Now the remainder of the proof becomes almost trivial:

As stated above, $\text{cod}(\alpha^{-1}) = \text{dom}(\alpha) = a' = \text{dom}(f')$. So $\text{dom}(f') = \text{cod}(\alpha^{-1})$, which means $f' \alpha^{-1}$ is a valid composition. With that in mind, we are now able to apply the logic quoted in the note above to show that $f' \alpha^{-1} = \beta f$; and this is sufficient to show that the second diagram commutes.

To show that the remaining diagrams commute, we must prove that $\beta^{-1} f' = f \alpha$ and that $\beta^{-1} f' \alpha^{-1} = f$, for the third and fourth diagrams respectively. Again, it is easy to obtain these expressions by composing β^{-1} with the expressions we have already determined – specifically, by taking the compositions $(\beta^{-1})f' = (\beta^{-1})\beta f \alpha = f \alpha$ for the third diagram and $(\beta^{-1})f' \alpha^{-1} = (\beta^{-1})\beta f = f$ for the fourth. The 'difficult' part is to show that these compositions are valid.

Fortunately, this is still fairly easy: the validity of $\beta^{-1}\beta$ is trivial, and $\text{dom}(\beta^{-1}) = \text{cod}(\beta) = b' = \text{cod}(f')$, so $\beta^{-1} f'$ is valid. This means that the compositions mentioned in the previous paragraph are valid, and therefore that $\beta^{-1} f' = f \alpha$ and $\beta^{-1} f' \alpha^{-1} = f$. So the third and fourth diagrams commute. \square

EXERCISE 1.5.iv. Show that a full and faithful functor $F: \mathbf{C} \rightarrow \mathbf{D}$ both **reflects** and **creates isomorphisms**. That is, show:

1. If f is a morphism in \mathbf{C} so that Ff is an isomorphism in \mathbf{D} , then f is an isomorphism.
2. If x and y are objects in \mathbf{C} so that Fx and Fy are isomorphic in \mathbf{D} , then x and y are isomorphic in \mathbf{C} .

PROOF. Consider categories \mathbf{C} and \mathbf{D} , and a functor $F: \mathbf{C} \rightarrow \mathbf{D}$ that is full and faithful. That is, for all $x, y \in \mathbf{C}$, the function $F: \mathbf{C}(x, y) \rightarrow \mathbf{D}(Fx, Fy)$ that takes f to Ff is bijective. Now, for a morphism $f: x \rightarrow y$, suppose that $Ff: Fx \rightarrow Fy$ is an isomorphism. This means that there exists $G: Fy \rightarrow Fx$ where $G(Ff) = 1_{Fx}$ and $Ff(G) = 1_{Fy}$. Now, we can apply the definition of full and faithful functor to see that $\mathbf{C}(y, x)$ is in bijection with $\mathbf{D}(Fy, Fx)$ and so there exists a unique $g \in \mathbf{C}(y, x)$ where $Fg = G$. We claim that $g = f^{-1}$.

To show this, we must show that $fg = 1_y$. We consider $F(fg)$, the image of fg under our full and faithful functor. We see that

$$F(fg) = FfFg = FfG = 1_{Fy} = F(1_y)$$

by properties of functors and our previous definitions of g and G . Since we know that $F: \mathbf{C}(y, y) \rightarrow \mathbf{D}(Fy, Fy)$ is bijective, $F(fg) = F(1_y)$ implies that $fg = 1_y$. We must also show that $gf = 1_x$. We use a similar method and show that

$$F(gf) = FgFf = G(Ff) = 1_{Fx} = F(1_x).$$

Since we again know that $F: \mathbf{C}(x, x) \rightarrow \mathbf{D}(Fx, Fx)$ is bijective, this implies that $gf = 1_x$. So we have that $fg = 1_y$ and that $gf = 1_x$. Therefore, f is an isomorphism with inverse g .

If Fx and Fy are isomorphic, we know that there exists some isomorphism $G: Fx \rightarrow Fy$. But since F is a full and faithful functor and therefore $\mathbf{C}(x, y)$ is in bijection with $\mathbf{D}(Fx, Fy)$, $G = Ff$ for some $f: x \rightarrow y$. By the previous part, we know that if Ff is an isomorphism, then f is also an isomorphism, so we see here that we have an isomorphism $f: x \rightarrow y$, and therefore x and y are isomorphic. \square

EXERCISE 1.5.v. Find an example to show that a faithful functor need not reflect isomorphisms.

PROOF. Let $F: \mathbf{2} \rightarrow \mathbf{1}$ be the unique morphism from $\mathbf{2}$ to $\mathbf{1}$. For $x, y \in \text{ob } \mathbf{2}$, $\mathbf{2}(x, y)$ either contains one morphism or is empty, thus the function from $\mathbf{2}(x, y)$ to $\mathbf{1}(0, 0)$ induced by F is injective. Thus, F is faithful. Let $!: 0 \rightarrow 1$ be the unique arrow from 0 to 1 . Since $F! = 1_0$ and $!$ is not an isomorphism, then F does not reflect isomorphisms. Thus faithful functors need not reflect isomorphisms. \square

LEMMA 1.3.8. *Functors preserve isomorphisms.*

THEOREM 1.5.9. (characterizing equivalences of categories). *A functor defining an equivalence of categories is full, faithful, and essentially surjective on objects. Assuming the axiom of choice, any functor with these properties defines an equivalence on categories.*

EXERCISE 1.5.vi.

- i Prove that the composite of a pair of full, faithful, or essentially surjective functors again has the same properties.
- ii Prove that if $\mathbf{C} \simeq \mathbf{D}$ and $\mathbf{D} \simeq \mathbf{E}$, then $\mathbf{C} \simeq \mathbf{E}$. Conclude that the equivalence of categories is an equivalence relation.

PROOF.

- Let $F: C \rightarrow D$ and $G: D \rightarrow E$ be functors. If F and G are full, but GF is not full, then there is some $c \in C(x, y)$, for some x, y which make sense, such that $GFc \notin E(GFx, GFy)$. However, $GFc = G(Fc) = Gd \in E(GFx, GFy)$ by the fullness of G , so GF is full.
To show that GF is faithful if F and G are faithful, by a similar argument, if GF were not faithful, then there would be a morphism in $E(GFx, GFy)$ mapped to by two morphisms of $C(x, y)$. However, $GFc = G(Fc) = Gd$ for a unique $d \in D(Fx, Fy)$, which is again injective by the faithfulness of G .
Finally, to show that GF is essentially surjective if F and G are essentially surjective, we see from Lemma 1.3.8 that functors take isomorphisms to isomorphisms. Since G is essentially surjective, for each $d \in D$, there is some $e \in E$ such that $Gd \cong e$. Then, since F has the same property, d must be isomorphic to some Fc , that is, $Fc \cong d$. So we have that $GFc \cong Gd \cong e$, which is the requirement for GF to be essentially surjective.
- If $C \simeq D$ and $D \simeq E$, then the functors F and G are fully faithful and essentially surjective, and by Theorem 1.5.9, $C \simeq E$. We also have that $C \simeq C$ (reflexivity), if $C \simeq D$ then $D \simeq C$ (symmetry), and from what we just showed we get transitivity. Thus, equivalence of categories defines an equivalence relation.

EXERCISE 1.5.vii. Let G be a connected groupoid and let BG be the group of automorphisms at any of its objects. The inclusion $BG \hookrightarrow G$ defines an equivalence of categories. Construct an inverse equivalence $G \rightarrow BG$.

PROOF. To construct the inverse equivalence between G and BG , we must find a fully faithful and essentially surjective functor between these categories. First, we see that since BG has just one object and any two singleton sets are isomorphic, that any functor $F: G \rightarrow BG$ will be essentially surjective. We define our functor F on the objects of G by sending any object of G to the one object of BG . Before defining our functor on morphisms, we first show that for every trio of objects $x, y, z \in G$, there exists a bijection from $G = G(x, x)$ to $G(y, z)$.

First, we define a class of reference morphisms for our groupoid in the following manner: Because G is connected, we have at least one morphism in $G(x, y)$ for any $y \in \text{ob } G$. By the Axiom of Choice, for each y , we can choose a morphism f_y .⁶

Now, we use this subclass of morphisms to first determine a bijection ρ between $G(x, x) \rightarrow G(x, y)$. We define this bijection by sending $\gamma \in G(x, x)$ to $f_y\gamma \in G(x, y)$. It is easy to see that this function is injective, because f_y is invertible, and surjective, as for any $g \in G(x, y)$, $g = \rho(f_y^{-1}g)$, where $f_y^{-1}g \in G(x, x)$. So we have the desired bijection.

Next, we see that we can define bijections σ from $G(x, x)$ to $G(y, x)$, where $\sigma(\gamma) = \gamma f_y^{-1}$ which is bijective by a similar argument as above. We can then compose these bijections to define a bijection $\phi = \sigma\rho$ from $G(x, x)$ to $G(y, z)$, where $\phi(\gamma) = f_z\gamma f_y^{-1}$.

⁶Note that if G is not small, we must apply the Axiom of Choice in a larger universe. Since G is a groupoid, we also have a morphism f_y^{-1} for each y . We also note that if $x = y$, we choose $f_y = 1_y$.

Clearly, we also have an inverse bijection $\phi^{-1}: \mathbf{G}(x, y) \rightarrow G$, where for a $g \in \mathbf{G}(y, z)$ such that $g = f_z \gamma f_y^{-1}$, $\phi^{-1}(g) = \gamma$. We will use this to define our functor on morphisms, so that for a morphism $g: y \rightarrow z$, $Fg = \phi^{-1}(g)$. First, we note that in this setting $f_x = 1_x$ and that for any y , $f_y = f_y \gamma f_x = f_y \gamma$, so that $Ff_y = 1_x$. Also, for any y , $1_y = f_y 1_x f_y^{-1}$, so our functor preserves identities.

Now, we show that our functor preserves composition of morphisms. To do this, consider $g: y \rightarrow z$ and $h: z \rightarrow w$, where $g = f_z \gamma_g f_y^{-1}$ and $h = f_w \gamma_h f_z^{-1}$. Now, consider Fhg . We know that $hg = f_w \gamma_h f_z^{-1} f_z \gamma_g f_y^{-1} = f_w \gamma_h \gamma_g f_y^{-1}$. So $Fhg = \gamma_h \gamma_g = FhFg$. So we see that our functor preserves composition of morphisms, and therefore we have a well defined functor.

To see that our functor is fully faithful, we remember that for any $y, z \in \text{ob } \mathbf{G}$, $\mathbf{G}(y, z)$ is in bijection with G . Since $Fy = Fz = \emptyset$, the only object of \mathbf{BG} , and the set $\mathbf{BG}(\emptyset, \emptyset) = G$, we have a bijection between $\mathbf{G}(y, z)$ and $\mathbf{BG}(Fy, Fz)$ and therefore a fully faithful functor. Therefore, we have a fully faithful functor that is essentially surjective on objects from \mathbf{G} to \mathbf{BG} .

Now, call the functor defined in 1.5.12 $\iota: \mathbf{BG} \rightarrow \mathbf{G}$. We must now define natural transformations $\tau: F\iota \Rightarrow 1_{\mathbf{BG}}$ and $\eta: 1_{\mathbf{G}} \Rightarrow \iota F$. For all $\gamma \in \text{mor } \mathbf{BG}$, we have that $F\iota(\gamma) = F(\gamma) = \gamma$ and that $F\iota(\emptyset) = Fx = \emptyset$ so $F\iota = 1_{\mathbf{BG}}$, and the natural transformation is the identity transformation. Now, for each $y \in \text{ob } \mathbf{G}$, we must find η_y , so that the following diagram commutes for every $f: y \rightarrow z$.

$$\begin{array}{ccc} \iota Fy = x & \xrightarrow{\iota Ff} & \iota Fz = x \\ \eta_y \downarrow & & \downarrow \eta_z \\ y & \xrightarrow{f} & z \end{array}$$

We claim that if $\eta_y = f_y$, the reference morphism picked earlier, then we will have formed a natural transformation. First, note that since f can be represented by $f_z \gamma f_y^{-1}$ for some automorphism $\gamma: x \rightarrow x$ and that $\gamma = f_z^{-1} f f_y$. Also, note that $\iota Ff = \iota(\gamma) = \gamma$. So we must show that $f_z \gamma = f f_y$. We know that $f_z \gamma = f_z f_z^{-1} f f_y = f f_y$, so we have the desired equality. So the following diagram commutes, and η is a natural transformation.

$$\begin{array}{ccc} x & \xrightarrow{\iota Ff} & x \\ f_y \downarrow & & \downarrow f_z \\ y & \xrightarrow{f} & z \end{array} \quad (1.1)$$

We also see that η_y is an isomorphism for every f_y , because \mathbf{G} is a groupoid. So we have shown the existence of the desired natural isomorphisms. Therefore, F and ι define an equivalence between the categories \mathbf{BG} and \mathbf{G} . \square

The exercise below concerns affine and projective planes as incidence geometries. For background, see Section 2.6 of Hartshorne's *Geometry: Euclid and Beyond*. I adapted the

following two definitions from that source⁷. The two examples that I give are standard examples with coordinates in a field k , but note that the definitions make no use of coordinates and the constructions that we will use do not either.

However, the constructions do have natural linear algebra interpretations in the examples with coordinates. I will use some basic facts from linear algebra concerning two and three dimensional vector spaces, such as properties of cross-product. If you do not recall these, then you may ignore the examples and concentrate on the rest.

DEFINITION. An *affine plane* is a triple of sets $\mathbb{A} = (A, L, I)$ with $A \cap L = \emptyset$ where the elements of A are called *points* and the elements of L are called *lines* satisfying the following additional requirements. $I \subseteq A \times L$ is a relation where $sI\ell$ is read as " s lies on ℓ ". \mathbb{A} satisfies the following axioms.

1. For any two distinct $s, t \in A$, there is a unique $\ell \in L$ such that s and t lie on ℓ .
2. For every $\ell \in L$ there are at least two distinct $s, t \in A$ that lie on ℓ .
3. There are at least three distinct $s, t, u \in A$ such that there is no $\ell \in L$ such that s, t and u all lie on ℓ .
4. Two lines ℓ and m are said to be *parallel* if either $\ell = m$ or there is no $s \in A$ that lies on both ℓ and m . Write $\ell \parallel m$ if ℓ and m are parallel. For every $\ell \in L$ and $s \in A$, there is a unique $m \in L$ such that $s \in m$ and $\ell \parallel m$.

DEFINITION. A *projective plane* is a triple of sets $\mathbb{P} = (P, L, I)$ with $P \cap L = \emptyset$ where the elements of P are called *points* and the elements of L are called *lines* satisfying the following additional requirements. $I \subseteq P \times L$ is a relation where $sI\ell$ is read as " s lies on ℓ ". \mathbb{P} satisfies the following axioms.

1. For any two distinct $s, t \in P$, there is a unique $\ell \in L$ such that s and t lie on ℓ .
2. For every $\ell \in L$ there are at least three distinct $s, t, u \in P$ that lie on ℓ .
3. There are at least three distinct $s, t, u \in P$ such that there is no $\ell \in L$ such that s, t and u all lie on ℓ .
4. For every $\ell, m \in L$ there is an $s \in P$ that lies on both ℓ and m .

Here are two easy lemmas and then two standard examples.

LEMMA. Let ℓ and m be two lines in an affine or projective plane and let s, t be distinct points that lie on both ℓ and m . Then $\ell = m$.

PROOF. The first property in each definition is that there is a unique line containing s and t , so $\ell = m$. □

LEMMA. In an affine plane (A, L, I) , \parallel is an equivalence relation.

PROOF. \parallel is clearly reflexive and symmetric. To see that it is transitive, say that $\ell \parallel m$ and $m \parallel n$. We must see that $\ell \parallel n$. If there is a point $s \in A$ such that s lies on both ℓ and n , then since there is a unique line parallel to m on which s lies, both ℓ and n are this line and $\ell = n$. Otherwise, there is no point lying on both ℓ and n . Either way, $\ell \parallel n$. □

⁷I added in each case that the set of points and the set of lines do not intersect so as to avoid annoying set-theoretic problems in the constructions

EXAMPLE. Let k be a field. Then $\mathbb{A}^2(k) = (k^2, L, \in)$ where the lines are solution sets to equations $ax + by + c = 0$ where $a, b, c \in k$ and at least one of a and b is not zero. Note that if $\lambda \in k^*$, then $ax + by + c = 0$ has the same solutions as $\lambda ax + \lambda by + \lambda c = 0$. This is the only way that two different equations yield the same line. Linear algebra tells us that $\mathbb{A}^2(k)$ satisfies the first property of an affine plane. It is not hard to prove via a parameterization that every line has the same number of elements as k , which is at least 2, so that the second property holds as well. An easy computation shows that for $(0, 0)$, $(1, 0)$ and $(0, 1)$ to all be solutions to $ax + by + c = 0$ then $a = b = c = 0$. So, we have three non-collinear points. Finally, if $s = (s_1, s_2)$ is not a solution to $ax + by + c = 0$, then there is a unique $d \in k$ such that s is a solution to $ax + by + d = 0$ and $d \neq c$. The lines defined by these two equations have empty intersection. So, $\mathbb{A}^2(k)$ satisfies all requirements of an affine plane.

Note that this example shows a way to construct finite affine planes. If $k = \mathbb{F}_q$, then $\mathbb{A}^2(\mathbb{F}_q)$ has q^2 points and $\frac{q(q^2-1)}{q-1} = q(q+1)$ lines. In fact, $\mathbb{A}^2(\mathbb{F}_2)$ with 4 points and 6 lines is the smallest possible affine plane.

EXAMPLE. Let k be a field. We will construct a projective plane for which the "points" are lines through the origin in k^3 , while the "lines" are planes through the origin in k^3 . More specifically, consider the equivalence relation \equiv on $k^3 \setminus \{(0, 0, 0)\}$ given by $(\alpha, \beta, \gamma) \equiv (\delta, \epsilon, \phi)$ if there is a $\lambda \in k^*$ such that $(\alpha, \beta, \gamma) = \lambda(\delta, \epsilon, \phi)$. That is, two nonzero vectors are equivalent if they are linearly dependent. (That is, determine the same line through the origin.) Denote the equivalence class of (α, β, γ) by $(\alpha : \beta : \gamma)$. For a linear polynomial $ax + by + cz$ with at least one of a, b, c not zero, if the equation $ax + by + cz = 0$ is satisfied by (α, β, γ) then it is also satisfied by everything in its equivalence class. Thus, it makes sense to say whether or not $(\alpha : \beta : \gamma)$ is a solution to $ax + by + cz = 0$.

$\mathbb{P}^2(k) = ((k^3 \setminus \{(0, 0, 0)\})/\equiv, L, \in)$ where the lines are solution sets to equations $ax + by + cz = 0$ with at least one of a, b, c nonzero. As in the previous example, for $\lambda \in k^*$ the solution sets of $ax + by + cz = 0$ and $\lambda ax + \lambda by + \lambda cz = 0$ are the same and this is the only way that two different equations yield the same line.

Starting with the second property, let $ax + by + cz = 0$ be the equation of a line ℓ . If at least two of a, b, c are not zero then $(b : -a : 0)$, $(c : 0 : -a)$ and $(0 : c : -b)$ are three distinct points on ℓ . If $a = b = 0$ so that $c \neq 0$, then $(1 : 0 : 0)$, $(0 : 1 : 0)$ and $(1 : 1 : 0)$ are three distinct points on ℓ . A similar construction applies if $a = c = 0$ or if $b = c = 0$.

Moving to the last property, if two distinct lines have equations $ax + by + cz = 0$ and $dx + ey + fz = 0$, then there is exactly one common solution given by the equivalence class of the cross-product $(a, b, c) \times (d, e, f)$. Thus, given lines ℓ and m , either $\ell = m$ or $\ell \cap m$ has just one point. In either case, $\ell \cap m \neq \emptyset$.

For the first property, given two distinct points s and t with representatives (s_1, s_2, s_3) and $t = (t_1, t_2, t_3)$ if we let $s \times t = (a, b, c)$ then at least one of a, b, c is not 0, since s and t are linearly independent, and s and t are both solutions of to the equation $ax + by + cz = 0$. This line is the unique line with this property, since as we have just seen any two lines that share more than one point are the same line.

Finally, $(1 : 0 : 0)$, $(0 : 1 : 0)$ and $(0 : 0 : 1)$ are not collinear since they are all solutions to $ax + by + cz = 0$ then $a = b = c = 0$. So, $\mathbb{P}^2(k)$ is a projective plane.

As in the previous example, this gives us a way to construct to finite projective planes

as $\mathbb{P}^2(\mathbb{F}_q)$ for finite fields \mathbb{F}_q , having $\frac{q^3-1}{q-1} = q^2 + q + 1$ points and also $q^2 + q + 1$ lines. The smallest possible projective plane is $\mathbb{P}^2(\mathbb{F}_2)$, which has 7 points and 7 lines. This projective plane is also known as the *Fano plane*.

PROPOSITION. *Let $\mathbb{P} = (P, L, I)$ be a projective plane and let $\ell_\infty \in L$. Let*

$$A = P \setminus \{s \in P \mid sI\ell_\infty\}, \quad L' = L \setminus \{\ell_\infty\}, \quad \text{and } I' = I \cap (A \times L').$$

Then (A, L', I') is an affine plane.

PROOF. For any two distinct $s, t \in A$ we also have that $s, t \in P$, so that there is a unique $\ell \in L$ such that s and t lie on ℓ . Since $s, t \in A$, $\ell \neq \ell_\infty$ so that $\ell \in L'$. This proves that (A, L', I') satisfies the first axiom of an affine plane.

For $\ell \in L'$, $\ell \neq \ell_\infty$ so that there is exactly one point that lies on both ℓ and ℓ_∞ . So, exactly one fewer points in A lie on ℓ than points in P lie on ℓ . Since at least three points in P lie on ℓ , at least two points in A lie on ℓ , satisfying the second axiom of an affine plane.

Since (P, L, I) is a projective plane, there are distinct $s, t, u \in P$ that are not collinear. In particular, at least one of them, say s , does not lie on ℓ_∞ . Thus, $s \in A$. Let $\ell \in L$ be the line determined by s and t and let $m \in L$ be the line determined by s and u . Note that $\ell \neq m$ since s, t, u are not collinear. Since there are at least two points of A lying on ℓ and at least two points of A lying on m , there is a $v \in A$ lying on ℓ with $v \neq s$ and a $w \in A$ lying on m with $w \neq s$. If s, v, w all lay on a common line, then that line would share two points each with ℓ and m , so that it would be equal to both ℓ and m . Since $\ell \neq m$, s, v, w do not lie on a common line, satisfying the third axiom of a projective plane.

Finally, let $s \in A$ and $\ell \in L'$. Let t be the unique point that lies on both ℓ and ℓ_∞ and let m be the line in \mathbb{P} determined by s and t . Since s lies on m , $m \neq \ell_\infty$ so that $m \in L'$. If s lies on ℓ then $\ell = m$. If not, then $\ell \neq m$ and since ℓ and m share the common point t in \mathbb{P} , they cannot share any points in A . In either case, $\ell \parallel m$ in \mathbb{A} . \square

EXERCISE 1.5.viii. Klein's Erlangen program studies groupoids of geometric spaces of various kinds. Prove that the groupoid **Affine** of affine planes is equivalent to the groupoid **Proj^l** of projective planes with a distinguished line, called the "line at infinity." The morphisms in each groupoid are bijections of both points and lines (preserving the distinguished line in the case of projective planes) that preserve and reflect the incidence relation. The functor **Proj^l** \rightarrow **Affine** removes the line at infinity and the points it contains. Explicitly describe an inverse equivalence.

That the functor $F : \mathbf{Proj}^l \rightarrow \mathbf{Affine}$ is well-defined on objects is shown by the proposition above. For a morphism $f : (P, L, I, \ell_\infty) \rightarrow (Q, M, J, m_\infty)$, the induced morphism $Ff : (A, L', I') \rightarrow (B, M', J')$ is given by restricting the bijections $P \rightarrow Q$ and $L \rightarrow M$ to A and to L' . These restrictions give bijections to B and to M' exactly because the bijection from L to M takes ℓ_∞ to m_∞ . Then it is easy to also see that Ff is a morphism, that F takes identities to identities and that F respects composition of morphisms. So, F is a functor.

We will now make a functor $G : \mathbf{Affine} \rightarrow \mathbf{Proj}^\ell$. First, we describe G on objects. Let (A, L, I) be an affine plane. Let Π be the set of equivalence classes of L under the relation \parallel . Let $P = A \cup \Pi$ and let $\bar{L} = L \cup \{\ell_\infty^*\}$ for some ℓ_∞^* that is not an element of $A \cup \Pi \cup L$. For the sake of definiteness, take $\ell_\infty^* = \{A \cup \Pi \cup L\}$. Let $\bar{I} \subseteq P \times \bar{L}$ be the relation defined by $s\bar{I}\ell$ if either

1. $s \in A, \ell \in L$ and $sI\ell$, or
2. $s \in \Pi$ and $\ell = \ell_\infty^*$, or
3. $s \in \Pi$ and $\ell \in s$.

We must see that (P, \bar{L}, \bar{I}) is a projective plane. First, we mention an annoying set theoretic issue. For this to be true, we need among other things that $P \cap \bar{L} = \emptyset$, which is true so long as $\Pi \cap L = \emptyset$. But, it is possible that one of the equivalence classes s of "lines" is already another "line" in L . We can avoid this by replacing each s by the Kuratowski product $s' = s \times L = \{\{s\}, \{s, L\}\}$. This cannot be equal to any $\ell \in L$ for if it were then $\ell \in L \in \{s, L\} \in s' = \ell$, and such loops are impossible under the ZFC axioms. We will move forward as if $\Pi \cap L = \emptyset$ so as to avoid obscuring the ideas under a weight of additional notation. But, everything below can be adjusted to use s' in place of s .

We will start by showing that any two distinct lines have exactly one common point. If $\ell, m \in \bar{L}$ then at least one of them, say ℓ , is in L . If $m = \ell_\infty^*$, then from the second and third cases of the definition of \bar{I} , we see that the only point that lies on both ℓ and ℓ_∞^* is the equivalence class s of ℓ under \parallel . If $m \in L$ as well then since $\ell \neq m$, either they are parallel in (A, L, I) , in which case the only $s \in P$ that lies on both is their common equivalence class, or they are not parallel, in which case they have one point in common via case (1), but have no point in common in Π .

Now, we will see that any two points determine a unique line. Let $s, t \in P$ be distinct points. They cannot both be on two different lines, since we have just seen that two lines have exactly one point in common. So, it suffices to show that they are on some line. If $s, t \in A$, then we already know that there is an $\ell \in L$ on which both s and t lie since (A, L, I) is an affine plane and I is preserved in \bar{I} via the first case of its definition. If $s, t \in \Pi$, then s and t both lie on ℓ_∞^* by case (2). We are left with the case in which one of them, say s , is in A and the other, t , is in Π . Then by the last axiom of an affine plane, there is a unique line $\ell \in L$ in the equivalence class t on which s lies. But, t also lies on ℓ by case (3).

Now we see that at least three distinct points lie on any line $\ell \in \bar{L}$. If $\ell \in L$, then there are at least 2 points in A that lie on ℓ . But, the equivalence class of ℓ is an element of Π that also lies on ℓ , giving ℓ at least 3 distinct points. The remaining case is $\ell = \ell_\infty^*$, whose points are the elements of Π . So, we must show that there are at least 3 equivalence classes of lines in A . To see that, recall that we are guaranteed three distinct points $s, t, u \in A$ such that there is no line on which they all lie. Let ℓ, m and n be the lines in (A, L, I) determined respectively by s and t , by s and u and by t and u . These three lines are distinct by the choice of s, t, u . But, each pair of ℓ, m, n has a point in common, so no pair is parallel. Therefore, we have at least three equivalence classes of parallel lines, giving at least three points lying on ℓ_∞^* .

Finally, we must guarantee that we have at least three $s, t, u \in P$ that do not lie on any common line in (P, \bar{L}, \bar{I}) . We may just take $s, t, u \in A$ that do not lie on a common line in (A, L, I) . Then they maintain this property in (P, \bar{L}, \bar{I}) .

So, we take $G(A, L, I) = (P, L, I, \ell_\infty^*)$, the projective plane just constructed with a distinguished line at infinity, also newly constructed.

Say that $f : (A, L, I) \rightarrow (B, M, J)$ is a morphism in **Affine**. We must describe

$$Gf : (P, \bar{L}, \bar{I}, \ell_\infty^*) \rightarrow (Q, \bar{M}, \bar{J}, m_\infty^*).$$

First note that since f is a bijection on both points and lines and also $sI\ell$ if and only if $f(s)Jf(\ell)$, it follows that $\ell \parallel m$ in (A, L, I) if and only if $f(\ell) \parallel f(m)$ in (B, M, J) . So, the bijection from L to M induces a bijection between parallel equivalence classes in L and in M . Thus, f extends to a bijection from P to Q . We also extend f to a bijection from \bar{L} to \bar{M} by taking ℓ_∞^* to m_∞^* . This gives a description of Gf as a function.

To see that Gf is a morphism in **Proj** ^{ℓ} , it remains to be seen that $s\bar{I}\bar{\ell}$ in (P, \bar{L}, \bar{I}) if and only if $Gf(s)\bar{J}Gf(\bar{\ell})$ in (Q, \bar{M}, \bar{J}) . Examining the three ways in which we could have $s\bar{I}\bar{\ell}$ in the definition of \bar{I} , we see that in each case $Gf(s)$ and $Gf(\bar{\ell})$ are in the very same case, and conversely. So, Gf is a morphism in **Proj** ^{ℓ} .

Now, it is easy to see that G takes identities to identities and preserves composition of morphisms. So, G is a functor.

Consider the composite functor $FG : \mathbf{Affine} \rightarrow \mathbf{Affine}$. G adds new points to A and a new line to L on which the new points lie, but F takes away that new line and also all of those new points returning us to A and to L . Also $(\bar{I})' = \bar{I} \cap (A \times L) = I$. So, on objects FG is the identity. But it is on morphisms as well, since as a function Gf is an extension of f to P and \bar{L} , but F just restricts Gf to the original sets, giving that $FGf = f$. So, $FG = 1_{\mathbf{Affine}}$.

However, $GF \neq 1_{\mathbf{Proj}^\ell}$. Indeed, if we write $A = P \setminus \{sI\ell_\infty\}$ and $L' = L \setminus \{\ell_\infty\}$ and $I' = I \cap (A \times L')$ as above, then

$$GF(P, L, I, \ell_\infty) = (A \cup \Pi, L' \cup \{\ell_\infty^*\}, \bar{I}', \ell_\infty^*).$$

But, there is a correspondence between what was taken away by F and what was added by G . Namely, if $s \in P$ lies on ℓ_∞ then the other lines on which s lies form an equivalence class $s^* \subset L'$ for \parallel in (A, L', I') . Indeed, any two distinct elements of s^* share s in P , and so cannot also share any points in A . Any two lines that are parallel in A must share a point in P , necessarily one that lies on ℓ_∞ . This gives a bijection

$$\{s \in P | sI\ell_\infty\} \leftrightarrow \{s^* \in \Pi\} = \{t \in A \cup \Pi | t\bar{I}'\ell_\infty^*\}.$$

We can fit these together into a natural transformation $\eta : 1_{\mathbf{Proj}^\ell} \Rightarrow GF$. Namely, if $\mathbb{P} = (P, L, I, \ell_\infty)$ then

$$\eta_{\mathbb{P}} : (P, L, I, \ell_\infty) \rightarrow (A \cup \Pi, L' \cup \{\ell_\infty^*\}, \bar{I}', \ell_\infty^*)$$

is given by

$$s \mapsto \begin{cases} s^* & \text{if } sI\ell_\infty \\ s & \text{otherwise, and} \end{cases}$$

$$\ell \mapsto \begin{cases} \ell_\infty^* & \text{if } \ell = \ell_\infty \\ \ell & \text{otherwise.} \end{cases}$$

It is easy to see that $\eta_{\mathbb{P}}$ is a morphism, and in particular an isomorphism as all morphisms in \mathbf{Proj}^ℓ are.

To check that η is a natural transformation, and thus a natural isomorphism, let⁸ $\mathbb{Q} = (Q, M, J, m_\infty)$ and $f : \mathbb{P} \rightarrow \mathbb{Q}$ be a morphism. Then we need to check that

$$\begin{array}{ccc} \mathbb{P} & \xrightarrow{f} & \mathbb{Q} \\ \eta_{\mathbb{P}} \downarrow & & \downarrow \eta_{\mathbb{Q}} \\ GF\mathbb{P} & \xrightarrow{GFf} & GF\mathbb{Q} \end{array}$$

commutes. Checking along both paths from \mathbb{P} to $GF\mathbb{Q}$, we find that both give

$$s \mapsto \begin{cases} f(s)^* & \text{if } sI\ell_\infty \\ f(s) & \text{otherwise, and} \end{cases}$$

$$\ell \mapsto \begin{cases} m_\infty^* & \text{if } \ell = \ell_\infty \\ f(\ell) & \text{otherwise.} \end{cases}$$

Since η is a natural isomorphism, we have that F and G define an equivalence of categories as claimed.

EXERCISE 1.5.ix. Show that any category equivalent to a locally small category is locally small.

PROOF. First, we will prove a much more general statement; that if there exists a faithful functor $F : \mathbf{C} \rightarrow \mathbf{D}$, where \mathbf{D} is a locally small category, then \mathbf{C} must be locally small. The proof follows:

$F : \mathbf{C} \rightarrow \mathbf{D}$ is faithful, so for any $x, y \in \mathbf{C}$, the map $F_{x,y} : \mathbf{C}(x, y) \rightarrow \mathbf{D}(Fx, Fy)$ is injective. And since there is an injective function $F_{x,y}$ from $\mathbf{C}(x, y) \rightarrow \mathbf{D}(Fx, Fy)$, there must be a surjective function $g : \mathbf{D}(Fx, Fy) \rightarrow \mathbf{C}(x, y)$ ⁹

⁸Note that \mathbb{Q} does not represent the rational numbers for the moment.

⁹The principle that “For two sets A and B , if there is a surjection from A to B , then there is an injection from B to A , and vice versa” is called the Partition Principle. While the principle has been known to be a consequence of the Axiom of Choice for quite awhile, it’s an open question whether or not it *implies* the Axiom of Choice—in other words, whether it is equivalent to the axiom. Bertrand Russell claimed it did, but he never provided a proof; and while set theorists as a whole have come incredibly close to one since then, they’ve never quite gotten there.

Per the Axiom of Replacement, the image of a function whose domain is a set must be a set, so the image of g is a set. But we just said that g is surjective over $\mathcal{C}(x, y)$, so its image is simply $\mathcal{C}(x, y)$; which means that $\mathcal{C}(x, y)$ must be a set! And since this holds for all $x, y \in \mathcal{C}$, \mathcal{C} must be locally small.

In the particular case specified by the exercise, wherein $\mathcal{C} \simeq \mathcal{D}$, there is by definition a faithful functor $F: \mathcal{C} \rightarrow \mathcal{D}$. So this is a special case of the general statement proven above; meaning we can immediately conclude that \mathcal{C} is locally small. \square

EXERCISE 1.5.x. Characterize the categories that are equivalent to discrete categories. A category that is connected and essentially discrete is called **chaotic**.

PROOF. We will show that a category \mathcal{C} is equivalent to a discrete category \mathcal{D} if and only if \mathcal{C} is preorder and a groupoid. Consider any category \mathcal{C} that is equivalent to a discrete category \mathcal{D} . By theorem 1.5.9 we have a full, faithful, and essentially surjective functor F from \mathcal{C} to \mathcal{D} . Since F is both full and faithful, we have for each x, y in $\text{ob } \mathcal{C}$ the map $\mathcal{C}(x, y) \rightarrow \mathcal{D}(Fx, Fy)$ is a bijection. Because \mathcal{D} is a discrete category we know that $\mathcal{D}(Fx, Fy)$ is empty if Fx and Fy are distinct or, if they are the same, consists of only the identity map. Since $\mathcal{C}(x, x) \rightarrow \mathcal{D}(Fx, Fx)$ is a bijection and $\mathcal{D}(Fx, Fx)$ only contains the identity map we can conclude that $\mathcal{C}(x, x)$ also only consists of the identity map. Now let $\mathcal{C}(x, y)$ be inhabited by f , so $\mathcal{D}(Fx, Fy)$ is inhabited as well and we must have $Fx = Fy$. Hence there must be exactly one morphism between x and y in \mathcal{C} . Using similar reasoning we can conclude $\mathcal{C}(y, x)$ has at most one element. Since both $\mathcal{C}(x, y)$ and $\mathcal{C}(y, x)$ are mapped to the identity of Fx we must have $fg = gf = 1_x$. Hence between any objects x and y in \mathcal{C} $\mathcal{C}(x, y)$ has exactly one member or is empty. Since every morphism in \mathcal{C} is invertible for any two objects x and y in \mathcal{C} there is at most one element in the $\mathcal{C}(x, y)$, \mathcal{C} is a groupoid and preorder as desired.

Conversely consider any category \mathcal{C} that is both a groupoid and a preorder. For insurance reasons we will work in a universe V , where \mathcal{C} is a small category. Now look at the skeleton category of \mathcal{C} , the category whose objects are exactly one element from each isomorphism classes (which we obtain by using the axiom of choice, and hence the reason for the insurance policy) of \mathcal{C} , denoted as $\mathfrak{S}_{\mathcal{C}}$. By definition we know that $\mathfrak{S}_{\mathcal{C}} \simeq \mathcal{C}$. Because \mathcal{C} is a groupoid, if $\mathcal{C}(x, y)$ is nonempty for any two objects x and y in \mathcal{C} , we must have that x is isomorphic to y and therefore in the same isomorphism class. Also since \mathcal{C} is a preorder there is at most one element in $\mathcal{C}(x, y)$. So all the morphisms of \mathcal{C} are collapsed into the identity morphisms of the appropriate isomorphism classes. Hence the only morphisms of $\mathfrak{S}_{\mathcal{C}}$ are the identities of each isomorphism class, so $\mathfrak{S}_{\mathcal{C}}$ is discrete category. Since equivalence is transitive \mathcal{C} is equivalent to a discrete category, and this completes the proof. \square

EXERCISE 1.5.xi. Consider the functors $\text{Ab} \rightarrow \text{Group}$ (inclusion), $\text{Ring} \rightarrow \text{Ab}$ (forgetting multiplication), $(-)^{\times}: \text{Ring} \rightarrow \text{Group}$ (taking the group of units), $\text{Ring} \rightarrow \text{Rng}$ (inclusion), $\text{Field} \rightarrow \text{Ring}$ (inclusion), and $\text{Mod}_R \rightarrow \text{Ab}$ (forgetful). Determine which functors are full, which are faithful, and which are essentially surjective. Do any define equivalence of

categories? (Warning: A few of these questions conceal research-level problems, but they can be fun to think about even if full solutions are hard to come by.)

Ab \rightarrow Group

PROOF. This is a fully faithful functor. For any two groups x and y , the functor maps the group homomorphisms $f: x \rightarrow y$ to themselves. In other words $Ff = f$. This immediately gives us that the functor is faithful, as if $Ff = Fg$, then $f = g$. For it to be full, we must confirm that for any groups $x, y \in \mathbf{Ab}$ that for any $g: Fx \rightarrow Fy$ we can find $f: x \rightarrow y$ such that $Ff = g$. But then we note that g is of domain x and codomain y as F is just inclusion, and that any homomorphism g between two Abelian groups in the category of groups also exists in the category of Abelian groups. Thus, we have the desired surjectivity.

However, our functor is not essentially surjective on objects. We know that for $c \in \mathbf{Ab}$, $Fc = c \in \mathbf{Group}$. For it to be essentially surjective, for any $d \in \mathbf{Group}$, we would need to be able to find an Fc isomorphic to it. But this just means we need to find an Abelian group isomorphic to d . That is impossible for any group d that is not Abelian, as Abelian groups are only isomorphic to Abelian groups. It thus does not define an equivalence of categories, however the Abelian groups are a subcategory. \square

Ring \rightarrow Ab

PROOF. Let F be the functor described above. The additive group of any ring is already abelian, so F takes the additive group of each $r \in \mathbf{Ring}$ (in other words, every $(r, +) \in \mathbf{Ring}$) to the same $(r, +) \in \mathbf{Ab}$; and takes every ring homomorphism $f: r \rightarrow s \in \mathbf{Ring}$ to $f_+: (r, +) \rightarrow (s, +) \in \mathbf{Ab}$, where we define f_+ as exactly the function f , but applied only to the additive group of r (instead of to the whole ring.)

So, in a sense, F is an 'inclusion functor,' taking the additive groups of elements of \mathbf{Ring} to those same groups in \mathbf{Ab} , and the ring homomorphisms between those additive group in \mathbf{Ring} to the same homomorphisms in \mathbf{Ab} .

When we say that F takes every morphism to 'itself', what we are really saying is the following: For any $f: r \rightarrow s \in \mathbf{Ring}$, if we define $f_+: (r, +) \rightarrow (s, +)$ as f applied to the additive group of r , we can say that $Ff = f_+ \in \mathbf{Ring}$. So it is trivial that for any $f, g: r \rightarrow s$ such that $Ff \neq Fg$, $f_+ \neq g_+$.

But the ring homomorphisms $f, g: r \rightarrow s$ can be equal only if $f(a + b) = g(a + b)$. In other words, $f = g$ only if $Ff = f_+ = g_+ = Fg$; so if $Ff \neq Fg$, then of course $f \neq g$! So $F(r, s)$ is injective by definition, and since this is the case for all $r, s \in \mathbf{Ring}$, we can conclude that F is faithful.

On the other hand, consider that there are no morphisms from the zero ring, $\{0\}$, to any nonzero $r \in \mathbf{Ring}$. $F\{0\}$ is simply $(\{0\}, +)$; that is, the trivial group. But there is automatically a group homomorphism from the trivial group to any group, which means that the set of morphisms from $F\{0\}$ to Fr is *not* empty for any $r \in \mathbf{Ring}$. So F cannot be surjective over $\{f: F\{0\} \rightarrow Fr\}$, which means F is not full.

Suppose to the contrary that F is essentially surjective. This means that, for example, there must be some $r \in \text{Ring}$ such that $Fr = (r, +) \simeq \mathbb{Q}/\mathbb{Z} \in \text{Ab}$. Consider that elements of \mathbb{Q}/\mathbb{Z} take the form $\{\frac{a}{b} + \mathbb{Z} \mid a, b \in \mathbb{Z}\}$; which means that for every $n \in \mathbb{Q}/\mathbb{Z}$, there is some positive integer b such that if you 'multiply' n by b (using the definition we mentioned earlier of "adding n to itself b times") you obtain that $b * n = a + \mathbb{Z} = \mathbb{Z} = 0_{\mathbb{Q}/\mathbb{Z}}$.

But consider the case where $n = 1_r$. We have just determined that there must be some positive integer b such that $b * 1 = 0$. This means that $(r, +)$ must have characteristic b , which itself means that every element of $(r, +)$ must have order $\leq b$. So since $(r, +) \simeq \mathbb{Q}/\mathbb{Z}$, every element of \mathbb{Q}/\mathbb{Z} must also have order $\leq b$. But we know that there is some element of \mathbb{Q}/\mathbb{Z} with order n for any positive n ; there cannot be a finite b such that every element of \mathbb{Q}/\mathbb{Z} has order $\leq b$. This brings us to a contradiction, which means that our assumption must be false – F must not be essentially surjective. \square

Ring \rightarrow Group

PROOF. An isomorphism of groups must preserve cardinality, among other things. Since there are groups of any finite order (consider the cyclic groups), to disprove that the functor is essential surjective it suffices to show that no ring can have a multiplicative group of a specific order. In particular we will consider five.

First, note that in any ring we may consider the multiplicative order of -1 , the additive inverse of 1 . If 1 is distinct from -1 , then -1 has order 2,¹⁰ implying that the multiplicative group of our ring must contain a subgroup of order two, and thus must have even order by Lagrange's theorem. We thus need only consider rings where 1 does not have a distinct additive inverse, i.e. rings of characteristic two.

Suppose that we have a ring R of characteristic two. If the multiplicative group of R has order five, then it must be isomorphic to $\mathbb{Z}/5\mathbb{Z}$ and thus have some element ζ with multiplicative order five, i.e. $\zeta^5 - 1 = 0$.

Now consider the polynomial ring $\mathbb{F}_2[x]$, and the evaluation map $ev_\zeta: \mathbb{F}_2[x] \rightarrow R$ which takes x to ζ . The polynomial $f(x) = x^5 - 1$ must be in the kernel of this map, and $x^5 - 1$ factors into $x + 1$ and $x^4 + x^3 + x^2 + x + 1$, both irreducible in $\mathbb{F}_2[x]$.¹¹

$\mathbb{F}_2[x]$ is a principle ideal domain, so $x^5 + 1$ must be contained in the ideal generated by itself or one of its factors.

...

So we may factor the evaluation map through the quotient of $\mathbb{F}_2[x]$ by $\ker ev_\zeta$, which must then embed \mathbb{F}_{16} in R meaning that it's multiplicative group has far more than just five elements. Thus the group $\mathbb{Z}/5\mathbb{Z}$ is completely missed by our functor which fails to be essentially surjective.

Now let us consider whether this functor is full or faithful. First, consider the ring of real numbers \mathbb{R} with their usual operations, this has no non-identity homomorphisms.

¹⁰We have $0 = -1 \cdot 0 = -1(-1 + 1) = -1 \cdot -1 + -1 \cdot 1 = -1 \cdot -1 + -1$ implying that $-1 \cdot -1$ is the additive inverse of -1 , so $-1 \cdot -1 = 1$.

¹¹To see this note first that it is neither divisible by x nor $x + 1$. So if it were divisible it would be so by two degree two polynomial. However, $x^2 + x + 1$ is the only irreducible degree two polynomial in $\mathbb{F}_2[x]$, and $(x^2 + x + 1)^2 = x^4 + x^2 + 1$.

However, if we consider only \mathbb{R}^\times , then there are many group homomorphisms. A typical homomorphism is raising an element to some power. Thus our functor cannot be full.

Finally, let R be a nonzero ring. For any polynomial p with coefficients in R , there is a ring endomorphism of $R[x]$ which takes x to p and thus any other polynomial q to $q(p)$. Note that most of these are not the identity homomorphism. However, if q is a constant polynomial, i.e. just an element of R , then $q(p) = q$. So these endomorphisms are all the identity when restricted to the inclusion of R in $R[x]$.

Further, the units of $R[x]$ are precisely the units of R .¹² This means that any of the endomorphisms above will also be the identity on the units of $R[x]$ which means that our functor is not injective on hom-sets. \square

Ring \rightarrow Rng

PROOF. Before defining the functor $\text{Ring} \rightarrow \text{Rng}$, first the category Rng needs some description. Since a rng, denoted here by R^- , is a non-unital ring, we note that $(R^-, +)$ is a commutative group and $(R^-, *)$ is a magma with associativity (or a monoid without the condition of identity). Thus every ring, R , is a rng by the fact that R is a monoid under multiplication, and this monoid is certainly a magma with associativity. So the objects in the category Ring are included in the class of objects of Rng .

Let the functor in question be the inclusion functor $\iota: \text{Ring} \rightarrow \text{Rng}$ that maps rings in Ring to rings in Rng , and ring homomorphisms in Ring to rng homomorphisms between rings in Rng . The rng homomorphisms have all of the properties of ring homomorphisms, except the condition of mapping units in one rng to units in another.

To test whether ι is a full functor, take $\mathbf{0}$ and \mathbb{Q} in Ring . Then $\iota\mathbf{0}, \iota\mathbb{Q}$ are rings included in Rng , and hence are the same $\mathbf{0}$ and \mathbb{Q} . Since there exists a rng homomorphism ϕ between $\mathbf{0}$ and \mathbb{Q} , i.e., the homomorphism that maps 0 to 0 , while there is no ring homomorphism between the same two objects in Ring , then ϕ is not mapped to by ι acting on any ring homomorphism in Ring . Thus, ι is not surjective between the morphisms fixed on any two objects in Ring . Hence ι is not full.

To test whether ι is faithful, for the objects $c \neq c'$ in Ring , take two homomorphisms ϕ_1 and ϕ_2 in Ring between c, c' . Applying ι to ϕ_1 and ϕ_2 yields $\iota\phi_1$ and $\iota\phi_2$, which remain unequal when applied to the objects $\iota c = c$ and $\iota c' = c'$. Thus ι is injective on morphisms between fixed objects in Ring . Thus ι is faithful.

To test whether ι is essentially surjective, we can take the object in Rng , E of even integers. Since $1 \notin E$, then E is not isomorphic to any ring that is also in Rng . Thus ι is not essentially surjective.

From the theorem characterizing the equivalence of categories, since ι fails to be a full functor from Ring to Rng , then there is not an equivalence of categories between Ring and Rng .

¹²Given an invertible element of R , its inverse is retained on inclusion in $R[x]$ making it a unit of $R[x]$. Conversely, multiplying non-constant polynomials increases their degree meaning they cannot multiply to 1, so these are all the units of $R[x]$.

Field \rightarrow Ring

PROOF. The inclusion functor $\iota: \text{Field} \rightarrow \text{Ring}$ is faithful: it must take each morphism in the domain to itself in the codomain and is thus injective. To show it is full, let $f: x \rightarrow y$ be a field homomorphism in Field . It must take $f(0_x) = 0_y$ and $f(1_x) = 1_y$. Since we are only concerned with morphisms between objects we know are fields in the domain (Field) of the functor, we know that in the codomain (Ring) every morphism between ιx and ιy must also have that $\iota f(0_x) = 0_{\iota x}$ and $\iota f(1_x) = 1_{\iota y}$ (and respect the rest of the ring homomorphism requirements). But then ιf must be a field homomorphism, and is thus included in Field .

The inclusion functor is not essentially surjective on objects however. There is no object in Field that this functor takes to the zero ring (and the zero ring is unique up to isomorphism). So, the inclusion map from $\text{Field} \rightarrow \text{Ring}$ does not define an equivalence of categories. \square

$\text{Mod}_R \rightarrow \text{Ab}$

PROOF. This functor is not always essentially surjective. If we let $R = \{0\}$, then the only object Mod_0 is the zero module. Thus $F0$ only goes to the trivial group. So if U were to be fully faithful in this case, every Abelian group must be isomorphic to the trivial group. This is clearly not the case since $\mathbb{Z}/2\mathbb{Z}$ (or any finite Abelian group really) cannot be isomorphic to the trivial group. However U is both full and faithful as $\text{Mod}_0(0, 0)$ and $\text{Ab}(F0, F0) = \text{Ab}(0, 0)$ both only have one element in them. So the only map between $\text{Mod}_0(0, 0) \rightarrow \text{Ab}(0, 0)$ takes the identity map in Mod_0 to the identity map in the trivial group, which is clearly bijective.

If we let $R = \mathbb{Z}$, recall that every abelian group can be uniquely expressed as a \mathbb{Z} -module. In this case since $\text{Mod}_{\mathbb{Z}}$ is exactly Ab , the forgetful functor U becomes the identity functor, so U is clearly full, faithful, and essentially surjective.

The previous two examples were both full, however, this need not always be the case. If we let $R = \mathbb{Z}_2[x]/x^2 + x + 1$, and look at R as a dimension one vector space over itself we have the following addition and multiplication tables.

+	0	1	α	$\alpha + 1$	*	0	1	α	$\alpha + 1$
0	0	1	α	$\alpha + 1$	0	0	0	0	0
1	1	0	$\alpha + 1$	α	1	0	1	α	$\alpha + 1$
α	α	$\alpha + 1$	0	1	α	0	α	$\alpha + 1$	1
$\alpha + 1$	$\alpha + 1$	α	1	0	$\alpha + 1$	0	$\alpha + 1$	1	α

Since R is rank one free module, every endomorphism on R is defined by scalar multiplication. Now forget the scalar multiplication on R , and treat R like an Abelian group. Since R is an Abelian group and in particular a field of characteristic two, the Frobenius endomorphism $a \mapsto a^p$, where p (in this case $p = 2$) is the characteristic of R (this is a field endomorphism so it preserves the additive structure as well even though it is defined in terms of the multiplicative operation which we have technically forgotten) is a member of $\text{Ab}(UR, UR)$. There is no module homomorphism that corresponds to the Frobenius endomorphism, since the Frobenius endomorphism fixes 0 and 1 and swaps α and $\alpha + 1$,

but every module homomorphism in this case can only fix one element at a time. (We know this because every endomorphism is multiplication by a scalar, so they are all completely described in the multiplication table.) Notice that this counterexample will work for any finite field with characteristic p .

Even though U is not always full, U is always faithful. If we say f and g are distinct morphisms in $\text{Mod}_R(x, y)$, then they must disagree on at least one element, say, z in x . Because Uf and Ug are exactly the same functions in $\text{Ab}(Ux, Uy)$ they disagree on the same element z , so they are distinct in $\text{Ab}(Ux, Uy)$ as well. Hence U is always faithful. \square

1.6 The art of the diagram chase

EXERCISE 1.6.i. Show that any map from a terminal object in a category to an initial one is an isomorphism. An object that is both initial and terminal is called a zero object.

PROOF. Let $f: t \rightarrow i$, where t is terminal and i is initial. As i is initial, there exists exactly one morphism $g: i \rightarrow t$. We must show this g is the inverse of f such that $fg = 1_i$ and $gf = 1_t$. We know that f and g are composable, and we know $fg: i \rightarrow i$ and $gf: t \rightarrow t$ based on the composition law. As i is initial, there exists exactly one morphism $i \rightarrow i$, the identity morphism 1_i . Thus, fg must be 1_i . Similarly, as t is terminal there exists exactly one morphism $c \rightarrow t$, and thus there exists only one morphism $t \rightarrow t$, the identity morphism 1_t . Hence gf must be 1_t , and f is an isomorphism. \square

EXERCISE 1.6.ii. Show that any two terminal objects in a category are connected by a unique isomorphism.

PROOF. Let t_0 and t_1 be two terminal objects in a category $f: X \rightarrow Y$. That means there is a unique homomorphism $f_0: x \rightarrow t_0$ and $f_1: x \rightarrow t_1$ for all x in X . We want to show that there is a unique isomorphism between t_0 and t_1 . Since t_0 is a terminal object, we have a morphism $f_0: t_1 \rightarrow t_0$. And since t_1 is a terminal object, we have a morphism $f_1: t_0 \rightarrow t_1$. Consider the composition f_0f_1 . This gives us $f_0f_1: t_0 \rightarrow t_1 \rightarrow t_0$ or more simply $f_0f_1: t_0 \rightarrow t_0$. So we must have that $f_0f_1 = 1_{t_0}$. Similarly, it must be that $f_1f_0 = 1_{t_1}$. This is exactly what it means to be isomorphic. Therefore any two terminal objects in a category are indeed connected by a unique isomorphism. \square

EXERCISE 1.6.iii. Show that any faithful functor reflects monomorphisms. That is, if $F: C \rightarrow D$ is faithful, prove that if Ff is a monomorphism in D , then f is a monomorphism in C . Argue by duality that faithful functors also reflect epimorphisms. Conclude that in any concrete category, any morphism that defines an injection of underlying sets is a monomorphism and any morphism that defines a surjection of underlying sets is an epimorphism.

PROOF. Suppose that $Ff: Fx \rightarrow Fy$ is a monomorphism in D , i.e. for any object w in C and parallel morphisms $h, k: w \rightrightarrows x$ then $FfFh = FfFk$ implies that $Fh = Fk$. (Because the property holds over all D , it holds in particular over the image of F in D .)

$$\begin{array}{ccccc}
 w & \xrightarrow{h} & x & \xrightarrow{f} & y \\
 & & \downarrow k & & \downarrow F \\
 Fw & \xrightarrow{Fh} & Fx & \xrightarrow{Ff} & Fy \\
 & & \downarrow Fk & & \downarrow F
 \end{array}$$

Now, supposing that $fh = fk$ in \mathbf{C} , this implies that $F(fh) = F(fk)$ by elementary properties of equality. Then by the functoriality axioms we have $FfFh = FfFk$, and by the fact that Ff is a monomorphism $Fh = Fk$. Finally since F is faithful and thus injective on $\mathbf{C}(w, x)$, $h = k$. This argument amounts to pushing equality clockwise around the above diagram.

Note that this also proves that a functor reflects epimorphisms, since an epimorphism is just a monomorphism in the opposite category. The argument above will compose neatly with applying the op functor at the beginning and end to transport us to the right category.

Further, given a concrete category \mathbf{C} we have a faithful functor from \mathbf{C} to \mathbf{Set} . Since monomorphisms in \mathbf{Set} are completely characterised by injectivity, this becomes sufficient condition for a map to be a monomorphism in \mathbf{C} . Similarly, surjectivity in \mathbf{Set} will force epic in \mathbf{C} . Frequently, the faithful functor in question is just the forgetful functor and the maps in \mathbf{C} are just functions defined on sets with peculiar features. Thus it is sensible to talk about injectivity and surjectivity in \mathbf{C} itself, and we can say that injectivity and surjectivity are sufficient—but not necessary—conditions for a map to be monic or epic respectively. \square

EXERCISE 1.6.iv. Find an example to show that a faithful functor need not preserve epimorphisms. Argue by duality, or by another counterexample, that a faithful functor need not preserve monomorphisms.

PROOF. Consider the category \mathbf{Ring} and the unique morphism $\phi: \mathbb{Z} \rightarrow \mathbb{Q}$. Exercise 1.2.v shows that ϕ is an epimorphism, however, it is easy to see that ϕ is not surjective. Now, consider a functor $F: \mathbf{Ring} \rightarrow \mathbf{Group}$ that takes a ring R to its additive group and a morphism $f: R \rightarrow S$ to the corresponding group homomorphism on the additive group. We see that this functor is faithful, because for fixed rings R and S and morphisms $f, g: R \rightarrow S$, $Ff = Fg$ implies that $Ff(x) = Fg(x)$ for all $x \in G_R$, the additive group of R , which has the same elements as R . But since by our definition $Ff(x) = f(x)$ and $Fg(x) = g(x)$, this implies that $f(x) = g(x)$ for all $x \in R$ and so $f = g$. Therefore, for all $x, y \in \mathbf{Ring}$, there is an injection from $\mathbf{Ring}(x, y) \rightarrow \mathbf{Group}(Fx, Fy)$ and therefore F is faithful. Now, note that in \mathbf{Group} , epimorphisms correspond exactly to surjective homomorphisms. But it is clear that $F\phi$ is not surjective, as its behavior on the elements of \mathbb{Z} and \mathbb{Q} is identical to that of ϕ . So $F\phi$ is not an epimorphism. Therefore, F does not preserve epimorphisms.

Now, we consider $F: \mathbf{Ring}^{\text{op}} \rightarrow \mathbf{Group}^{\text{op}}$, where F acts on objects and morphisms as before. By 1.3.v, there is no difference between a functor from \mathbf{Ring} to \mathbf{Group} and a functor from $\mathbf{Ring}^{\text{op}}$ to $\mathbf{Group}^{\text{op}}$, so F is still faithful in this setting. Now, we note that the epimorphisms in \mathbf{Ring} and \mathbf{Group} are precisely the monomorphisms in $\mathbf{Ring}^{\text{op}}$ and $\mathbf{Group}^{\text{op}}$. So ϕ is a monomorphism in $\mathbf{Ring}^{\text{op}}$, but not in $\mathbf{Group}^{\text{op}}$. Therefore, F does not preserve monomorphisms. So a faithful functor need not preserve monomorphisms. \square

EXERCISE 1.6.v. Find a concrete category that contains a monomorphism whose underlying function is not injective. Find a concrete category that contains an epimorphism whose underlying function is not surjective.

PROOF. For the first example, take a subcategory of \mathbf{Set} , \mathbf{C} , consisting of two objects, A being the set with elements 0, 1, and 2, and B being the set with elements 0, and 1. Take as morphisms between A and B the identity morphisms, 1_A and 1_B , along with the morphism, $f: A \rightarrow B$, defined by $f(0) = 0$, $f(1) = 0$, and $f(2) = 0$. Since $fg = fh$ implies $g = h = 1_A$, then f is a monomorphism. Yet since f sends 0 to 0 and 1 to 0 in the underlying sets, then f is not injective.

For the second example, take the objects \mathbb{Z} and \mathbb{Q} in the category \mathbf{Ring} . There is a unique ring homomorphism between \mathbb{Z} and \mathbb{Q} . This homomorphism is not surjective on the underlying sets, yet from the previous exercise 1.2.v, this homomorphism is an epimorphism. \square

EXERCISE 1.6.vi. A **coalgebra** for an endofunctor $T: \mathbf{C} \rightarrow \mathbf{C}$ is an object $C \in \mathbf{C}$ equipped with a map $\gamma: C \rightarrow TC$. A morphism $f: (C, \gamma) \rightarrow (C', \gamma')$ of coalgebras is a map $f: C \rightarrow C'$ so that the following square commutes.

$$\begin{array}{ccc} C & \xrightarrow{f} & C' \\ \gamma \downarrow & & \downarrow \gamma' \\ TC & \xrightarrow{Tf} & TC' \end{array}$$

Prove that if (C, γ) is a **terminal coalgebra**, that is a terminal object in the category of coalgebras, then the map $\gamma: C \rightarrow TC$ is an isomorphism.

PROOF. Suppose that $T: \mathbf{C} \rightarrow \mathbf{C}$ is an endofunctor and (C, γ) a terminal coalgebra. Let $\chi: TC \rightarrow C$ be the unique morphism so that the following diagram commutes.

$$\begin{array}{ccc} TC & \xrightarrow{\chi} & C \\ T\gamma \downarrow & & \downarrow \gamma \\ TTC & \xrightarrow{T\chi} & TC \end{array}$$

Then we have that:

$$\gamma\chi = T(\chi\gamma)$$

Now we will to show that the diagram

$$\begin{array}{ccc} C & \xrightarrow{\chi\gamma} & C \\ \gamma \downarrow & & \downarrow \gamma \\ TC & \xrightarrow{T(\chi\gamma)} & TC \end{array}$$

commutes. Since $\gamma\chi = T(\chi\gamma)$, then composing γ on the right will give

$$\gamma\chi\gamma = T(\chi\gamma)\gamma,$$

which shows that the diagram above commutes. This means that the morphism $\chi\gamma$ uniquely allows the diagram above to commute. The identity morphism 1_C gives an endomorphism of the terminal coalgebra (C, γ) since $\gamma 1_C = T 1_C \gamma = 1_{TC} \gamma$ by the properties of identity morphisms, thus $\chi\gamma = 1_C$. This will give us

$$\gamma\chi = T(\chi\gamma) = T 1_C = 1_{TC}.$$

Thus χ and γ are inverses, therefore γ is an isomorphism. □

An example of a co-algebra is one defined by the endofunctor $P_{\text{fin}}: \text{Set} \rightarrow \text{Set}$ where P_{fin} is the functor mapping a set X to the set of finite subsets of X , and maps a morphism $f: X \rightarrow Y$ to $P_{\text{fin}}f: P_{\text{fin}}X \rightarrow P_{\text{fin}}Y$ where for finite subset S of X , $P_{\text{fin}}f(S) = f(S)$.

1.7 The 2-category of categories

EXERCISE 1.7.i. Prove that if \mathbf{C} is small and \mathbf{D} is locally small, then $\mathbf{D}^{\mathbf{C}}$ is locally small by defining a monomorphism from the collection of natural transformations between a fixed pair of functors $F, G: \mathbf{C} \Rightarrow \mathbf{D}$ into a set. (Hint: Think about the function that sends a natural transformation to its collection of components.)

PROOF. Let $\gamma: \text{Nat}(F, G) \rightarrow \text{Set}$, given by $\alpha \mapsto \{\alpha_c \in \text{mor } \mathbf{D}\}$ where $\alpha: F \Rightarrow G \in \text{Nat}(F, G)$. We must show that $\{\alpha_c \in \text{mor } \mathbf{D}\}$ is a set. We can do this by noting that since \mathbf{D} is locally small, $\mathbf{D}(x, y)$ is a set for all choices of x, y . Let $\delta: \text{ob } \mathbf{C} \rightarrow \mathcal{P}(\text{mor } \mathbf{D})$, given by $c \mapsto \mathbf{D}(Fc, Gc)$, where $\mathcal{P}(\text{mor } \mathbf{D})$ is the power class of $\text{mor } \mathbf{D}$. We know that $\mathbf{D}(Fc, Gc) \in \mathcal{P}(\text{mor } \mathbf{D})$, and since $\text{ob } \mathbf{C}$ is a set, the range of δ is a set by the Axiom of Replacement. Taking the union of the range of δ , which is also a set, gives us a set that contains all of the possible natural transformations from F to G .

So γ sends any natural transformation to an element of this new set. Since the class of functions between pairs of sets is a set, and that the class of natural transformations between F and G is a subclass of this set, we have that these transformations form a set by restricted comprehension. Then, $\mathbf{D}^{\mathbf{C}}$ is locally small. \square

EXERCISE 1.7.ii. Given a natural transformation $\beta: H \Rightarrow K$ and functors F and L , define a natural transformation $L\beta F: LHF \Rightarrow LKF$ by $(L\beta F)_c = L\beta_{Fc}$. This is the whiskered composite of β with L and F . Prove that $L\beta F$ is natural.

PROOF. By β being natural, we have for $g: d \rightarrow d'$ where $d, d' \in \mathbf{D}$,

$$(Kg)\beta_d = \beta_{d'}(Hg).$$

But if instead we take $Ff: Fc \rightarrow Fc'$ for $c, c' \in \mathbf{C}$ we can get

$$(KFf)\beta_{Fc} = \beta_{Fc'}(HFf).$$

Now by Lemma 1.6.5, applying the functor L preserves the commutative diagram

$$(LKFf)(L\beta_{Fc}) = (L\beta_{Fc'})(LHFf).$$

$$\begin{array}{ccccc} Hd & \xrightarrow{Hf} & Hd' & & HFc & \xrightarrow{HFf} & HFc' & & LHFc & \xrightarrow{LHFf} & LHFc' \\ \beta_d \downarrow & & \downarrow \beta_{d'} & & \beta_{Fc} \downarrow & & \downarrow \beta_{Fc'} & & L\beta_{Fc} \downarrow & & \downarrow L\beta_{Fc'} \\ Kd & \xrightarrow{Kf} & Kd' & & KFc & \xrightarrow{KFf} & KFc' & & LKFc & \xrightarrow{LKFf} & LKFc' \end{array}$$

EXERCISE 1.7.iii. Redefine the horizontal composition of natural transformations introduced in Lemma 1.7.4 using vertical composition and whiskering.

PROOF. Consider categories C, D , and E , with functors $F, G: C \rightarrow D$ and $H, K: D \rightarrow E$ with natural transformations $\alpha: F \Rightarrow G$ and $\beta: H \Rightarrow K$. This is the same as in the construction for horizontal composition given in Lemma 1.7.4. Now consider a whiskering such that the first functor is the identity functor, or in other words a natural transformation $H\alpha: HF \Rightarrow HG$ defined by $(H\alpha)_c = H\alpha_c$. Then consider a second whiskering such that the last functor is an identity functor, or in other words a natural transformation $\beta G: HG \Rightarrow KG$ defined by $(\beta G)_c = \beta_{Gc}$. Now we can vertically compose these two natural transformations to get $\beta G \cdot H\alpha: HF \Rightarrow KG$. This is definitionally the same as the horizontal composition natural transformation:

$$(\beta * \alpha)_c = \beta_{Gc} H\alpha_c = (\beta G \cdot H\alpha)_c.$$

EXERCISE 1.7.iv. Prove Lemma 1.7.7.

LEMMA 1.7.7 (middle four interchange). *Given functors and natural transformation*

$$\begin{array}{ccc} \begin{array}{c} \xrightarrow{F} \\ \Downarrow \alpha \\ \xrightarrow{G} \end{array} & & \begin{array}{c} \xrightarrow{J} \\ \Downarrow \gamma \\ \xrightarrow{K} \end{array} \\ C & \xrightarrow{G} & D & \xrightarrow{K} & E \\ \begin{array}{c} \xrightarrow{H} \\ \Downarrow \beta \\ \xrightarrow{H} \end{array} & & \begin{array}{c} \xrightarrow{L} \\ \Downarrow \delta \\ \xrightarrow{L} \end{array} \end{array}$$

the natural transformation $JF \Rightarrow LH$ defined by first composing vertically and then composing horizontally equals the natural transformation defined by first composing horizontally and then composing vertically:

$$\begin{array}{ccc} \begin{array}{c} \xrightarrow{F} \\ \Downarrow \alpha \\ \xrightarrow{G} \end{array} & & \begin{array}{c} \xrightarrow{J} \\ \Downarrow \gamma \\ \xrightarrow{K} \end{array} \\ C & \xrightarrow{G} & D & \xrightarrow{K} & E \\ \begin{array}{c} \xrightarrow{H} \\ \Downarrow \beta \\ \xrightarrow{H} \end{array} & & \begin{array}{c} \xrightarrow{L} \\ \Downarrow \delta \\ \xrightarrow{L} \end{array} \end{array} = \begin{array}{ccc} \begin{array}{c} \xrightarrow{JF} \\ \Downarrow \gamma * \alpha \\ \xrightarrow{KG} \end{array} & & \\ C & \xrightarrow{KG} & E \\ \begin{array}{c} \xrightarrow{LH} \\ \Downarrow \delta * \beta \\ \xrightarrow{LH} \end{array} & & \end{array}$$

Before proceeding with the proof, let us elaborate on exactly how horizontal and vertical composition work. Vertical composition is the simpler of the two since it is just composition of morphisms in the target category of our functors. Precisely, given parallel functors and accompanying natural transformations we can compose the component maps α_c and β_c for

any object c in \mathbf{C} . That this defines a new natural transformation $\beta \cdot \alpha: F \Rightarrow H$ follows immediately.

$$\begin{array}{ccc} \begin{array}{c} F \\ \Downarrow \alpha \\ \mathbf{C} - G \rightarrow \mathbf{D} \\ \Downarrow \beta \\ H \end{array} & \sim & \begin{array}{ccccc} Fc & \xrightarrow{\alpha_c} & Gc & \xrightarrow{\beta_c} & Hc \\ \downarrow Ff & \dashrightarrow & \downarrow Gf & \dashrightarrow & \downarrow Hf \\ Fd & \xrightarrow{\alpha_d} & Gd & \xrightarrow{\beta_d} & Hd \end{array} \end{array}$$

Horizontal composition is more involved. Note that one way to think of natural transformations is as mapping objects to morphisms and morphisms to commutative squares in the target category. Given $\alpha: F \Rightarrow G$ where $F, G: \mathbf{C} \Rightarrow \mathbf{D}$ and $f: c \rightarrow d$, the object c is taken to a morphism α_c and the arrow f is taking to a square of morphisms connecting Fc to Gd . Because this square commutes there is a unique composite arrow from Fc to Gd . Horizontal composition is then applying the natural transformation γ to Fc , Gc , and the map α_c between them. Given $\gamma: J \Rightarrow K$ and $J, K: \mathbf{D} \Rightarrow \mathbf{E}$ By naturality, there is again a unique composite arrow denoted $(\gamma * \alpha)_c$ which will form the c component of the new natural transformation.

$$\begin{array}{ccc} c & \xrightarrow{f} & d \\ \downarrow & & \downarrow \\ Fc & \xrightarrow{Ff} & Fd \\ \alpha_c \downarrow & \dashrightarrow & \downarrow \alpha_d \\ Gc & \xrightarrow{Gf} & Gd \end{array} \quad \sim \quad \begin{array}{ccc} Fc & \mapsto & JFc \xrightarrow{\gamma_{Fc}} KFc \\ \alpha_c \downarrow & \mapsto & J\alpha_c \downarrow \quad (\gamma * \alpha)_c \quad \downarrow J\alpha_c \\ Gc & \mapsto & JGc \xrightarrow{\gamma_{Gc}} KGc \end{array}$$

PROOF. At a first pass this lemma is telling us that $(\delta \cdot \gamma) * (\beta \cdot \alpha) = (\gamma * \alpha) \cdot (\delta * \beta)$. For a specific object c in \mathbf{C} this means the following diagrams are equivalent:

$$\begin{array}{ccc} \begin{array}{ccccc} JFc & \xrightarrow{\gamma_{Fc}} & KFc & & \\ J\alpha_c \downarrow & \dashrightarrow & \downarrow K\alpha_c & & \\ JGc & \xrightarrow{\gamma_{Gc}} & KGc & \xrightarrow{\delta_{Gc}} & LGc \\ K\beta_c \downarrow & \dashrightarrow & \downarrow (\delta * \beta)_c & \dashrightarrow & \downarrow L\beta_c \\ KHC & \xrightarrow{\delta_{Hc}} & LHC & & \end{array} & = & \begin{array}{ccccc} & & & & (\delta \cdot \gamma)_{Fc} \\ JFc & \xrightarrow{\gamma_{Fc}} & KFc & \xrightarrow{\delta_{Fc}} & LFc \\ J\alpha_c \downarrow & \dashrightarrow & \downarrow J\alpha_c & \dashrightarrow & \downarrow L\alpha_c \\ JGc & \xrightarrow{\gamma_{Gc}} & KGc & \xrightarrow{(\delta \cdot \gamma) * (\beta \cdot \alpha)} & LGc \\ J\beta_c \downarrow & \dashrightarrow & \downarrow J\beta_c & \dashrightarrow & \downarrow L\beta_c \\ JHc & \xrightarrow{\gamma_{Hc}} & KHC & \xrightarrow{\delta_{Hc}} & LHC \\ & & & & (\delta \cdot \gamma)_c \end{array} \end{array}$$

We may extend the left diagram to the following without disturbing commutativity, implying

that the diagonal map in each case is the same.

$$\begin{array}{ccccc}
 JFc & \xrightarrow{\gamma_{Fc}} & KFc & \xrightarrow{\delta_{Fc}} & LFc \\
 J\alpha_c \downarrow & \searrow (\gamma*\alpha)_c & \downarrow K\alpha_c & & \downarrow L\alpha_c \\
 JGc & \xrightarrow{\gamma_{Gc}} & KGc & \xrightarrow{\delta_{Gc}} & LGc \\
 J\beta_c \downarrow & & \downarrow K\beta_c & \searrow (\delta*\beta)_c & \downarrow L\beta_c \\
 JHc & \xrightarrow{\gamma_{Hc}} & KHc & \xrightarrow{\delta_{Hc}} & LHc
 \end{array}$$

In particular note that the top right and bottom left quadrants themselves are the diagram associated with the horizontal compositions $\delta * \alpha$ and $\gamma * \beta$ and for the object c , which thus must commute, making the entire diagram commute. \square

EXERCISE 1.7.v. Show that for any category \mathbf{C} , the collection of natural endomorphisms of the identity functor $1_{\mathbf{C}}$ defines a commutative monoid, called the **center of the category**. The proof of Proposition 1.4.4 demonstrates that the center of \mathbf{Ab}_{fg} is the multiplicative monoid $(\mathbb{Z}, \times, 1)$.

PROOF. The identity functor $1_{\mathbf{C}}$ is a functor taking the objects and morphisms of \mathbf{C} to themselves. A natural endomorphism is a natural transformation in which every component α_c is an endomorphism of c . We will construct an argument using the horizontal and vertical composition of natural transformations. Let $\alpha, \beta: 1_{\mathbf{C}} \Rightarrow 1_{\mathbf{C}}$ be natural endomorphisms of $1_{\mathbf{C}}$. We have the following diagram (with equality by horizontal composition):

$$\begin{array}{ccc}
 \begin{array}{ccc}
 \mathbf{C} & \xrightarrow{1_{\mathbf{C}}} & \mathbf{C} \\
 \downarrow \alpha & & \downarrow \beta \\
 \mathbf{C} & \xrightarrow{1_{\mathbf{C}}} & \mathbf{C}
 \end{array} & = & \begin{array}{ccc}
 \mathbf{C} & \xrightarrow{1_{\mathbf{C}}1_{\mathbf{C}}} & \mathbf{C} \\
 \downarrow (\beta*\alpha) & & \downarrow 1_{\mathbf{C}}1_{\mathbf{C}} \\
 \mathbf{C} & \xrightarrow{1_{\mathbf{C}}1_{\mathbf{C}}} & \mathbf{C}
 \end{array}
 \end{array}$$

From this we get the following commutative diagram:

$$\begin{array}{ccc}
 1_{\mathbf{C}}1_{\mathbf{C}}c & \xrightarrow{\beta_{1_{\mathbf{C}}c}} & 1_{\mathbf{C}}1_{\mathbf{C}}c \\
 1_{\mathbf{C}}\alpha_c \downarrow & \searrow (\beta*\alpha)_c & \downarrow 1_{\mathbf{C}}\alpha_c \\
 1_{\mathbf{C}}1_{\mathbf{C}}c & \xrightarrow{\beta_{1_{\mathbf{C}}c}} & 1_{\mathbf{C}}1_{\mathbf{C}}c
 \end{array}$$

Which can be simplified to:

$$\begin{array}{ccc}
 c & \xrightarrow{\beta_c} & c \\
 \alpha_c \downarrow & \searrow (\beta*\alpha)_c & \downarrow \alpha_c \\
 c & \xrightarrow{\beta_c} & c
 \end{array}$$

Where we can see that $(\beta * \alpha)_c : c \rightarrow c$, and that $(\beta * \alpha)_c = \alpha_c \beta_c = \beta_c \alpha_c = (\beta \cdot \alpha)_c$. This shows that in this case, horizontal and vertical composition are equivalent and commutative. It remains to show that they are associative. To show this, we will perform vertical composition with three functors $\alpha, \beta, \delta : 1_C \Rightarrow 1_C$ by performing the composition of the bottom pair first, then the top pair first, and comparing the result.

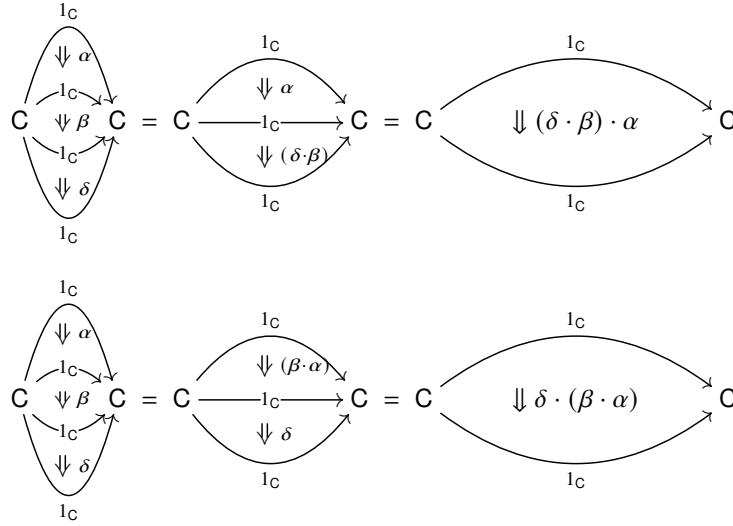

So, $(\delta \cdot \beta) \cdot \alpha = \delta \cdot (\beta \cdot \alpha)$, giving us associativity.

These functors have components for all $c \in C$, their composition is commutative, associative, and closed over C . Finally, there is an identity natural endomorphism which takes $c \in \text{ob } C$ to $\text{id}_c \in \text{mor } C$. So we have the requirements to say that the natural endomorphisms of the identity functor on a category C form a commutative monoid. \square

EXERCISE 1.7.vi. Suppose the functors and natural transformations

$$\begin{array}{ccc} C \xrightleftharpoons[G]{F} D & \eta : 1_C \cong GF & \epsilon : FG \cong 1_D \\ D \xrightleftharpoons[G']{F'} E & \eta' : 1_D \cong G'F' & \epsilon' : F'G' \cong 1_E \end{array}$$

define equivalences of categories $C \simeq D$ and $D \simeq E$. Prove (again) that there is a composite equivalence of categories $C \simeq E$ by defining composite natural isomorphisms $1_C \cong GG'F'F$ and $F'FGG' \cong 1_E$.

PROOF. First, we would like to make an additional remark on Exercise 1.7.ii. In that exercise, given functors $F : C \rightarrow D$, $H : D \rightarrow E$, $K : D \rightarrow E$ and $L : E \rightarrow F$ and a natural

transformation $\beta: H \Rightarrow K$, we obtained a natural transformation $L\beta F: LHF \Rightarrow LKF$, the *whiskered composite* of β with L and F , given by $(L\beta F)_c = L\beta_{Fc}$.

We claim that if β is a natural isomorphism, then so is $L\beta F$. Indeed, if β is a natural isomorphism then β_d is an isomorphism for every object d of D . So, β_{Fc} is an isomorphism for every object c of C . By Lemma 1.3.8, $L\beta_{Fc}$ is an isomorphism as well, showing that $L\beta F$ is a natural isomorphism as claimed.

Similarly, note that the vertical composition $\alpha \cdot \beta$ of two natural isomorphisms is a natural isomorphism since its component morphisms $(\alpha \cdot \beta)_c = \alpha_c \beta_c$ are compositions of isomorphisms.

Now to the exercise at hand. From

$$\begin{array}{ccccc} & & 1_D & & \\ & & \Downarrow \eta' & & \\ C & \xrightarrow{F} & D & \xrightarrow{G} & D & \xrightarrow{G} & C \\ & & \Uparrow G'F' & & \end{array}$$

we obtain the natural isomorphism $G\eta'F: GF \Rightarrow GG'F'F$. Thus, we have a natural isomorphism $(G\eta'F) \cdot \eta: 1_C \Rightarrow GG'F'F$.

For the other direction, we consider the whiskered composite

$$\begin{array}{ccccc} & & FG & & \\ & & \Downarrow \epsilon & & \\ E & \xrightarrow{G'} & D & \xrightarrow{F'} & D & \xrightarrow{F'} & E \\ & & \Uparrow 1_D & & \end{array}$$

giving the natural isomorphism $F'\epsilon G': F'FGG' \Rightarrow F'G'$. Vertical composition with ϵ' gives the natural isomorphism $\epsilon' \cdot (F'\epsilon G'): F'FGG' \Rightarrow 1_E$ as required. \square

EXERCISE 1.7.vii. Prove that a bifunctor $F: C \times D \rightarrow E$ determines and is uniquely determined by:

1. A functor $F(c, -): D \rightarrow E$ for each $c \in C$.
2. A natural transformation $F(f, -): F(c, -) \Rightarrow F(c', -)$ for each $f: c \rightarrow c'$ in C .

In other words, prove that there is a bijection between functors $C \times D \rightarrow E$ and functors $C \rightarrow E^D$. By symmetry of the product of categories, these classes of functors are also in bijection with functors $D \rightarrow E^C$.

PROOF. From the category C , fix an object c in the bifunctor $F: C \times D \rightarrow E$. To find a functor $F(c, -): D \rightarrow E$, define $F(c, -)(d) = F(c, d)$. With c fixed, and $g: d \rightarrow d'$, then $F(c, -)(g) = F(1_c, g)$. For a natural transformation $F(f, -): F(c, -) \Rightarrow F(c', -)$, take as components of the natural transformation $F(f, -)_d = F(f, 1_d): F(c, d) \rightarrow F(c', d)$. Checking the naturality, $F(1_{c'}, g)F(f, 1_d) = F(f, 1_{d'})F(1_c, g)$, whenever $(1_{c'}, g)(f, 1_d) = (f, 1_{d'})(1_c, g)$. Thus $F(f, -): F(c, -) \Rightarrow F(c', -)$ is a natural transformation, and conditions (i) and (ii) are determined by the bifunctor $F: C \times D \rightarrow E$.

Similarly, with the definitions that for a fixed c in C , $F(c, d) = F(c, -)(d)$ and $F(1_c, g) = F(c, -)(g)$, along with the natural transformation $F(f, -)_d = F(f, 1_d): F(c, d) \rightarrow F(c', d)$, such that $F(1_{c'}, g)F(f, 1_d) = F(f, 1_{d'})F(1_c, g)$, whenever $(1_{c'}, g)(f, 1_d) = (f, 1_{d'})(1_c, g)$, the bifunctor $F: C \times D \rightarrow E$ is determined. \square

Chapter 2

Universal Properties, Representability, and the Yoneda Lemma

2.1 Representable functors

EXERCISE 2.1.i. For each of the three functors

$$\mathbb{1} \begin{array}{c} \xrightarrow{0} \\ \xleftarrow{!} \\ \xrightarrow{1} \end{array} \mathbb{2}$$

between the categories $\mathbb{1}$ and $\mathbb{2}$, describe the corresponding natural transformations between the covariant functors $\text{Cat} \Rightarrow \text{Set}$ represented by the categories $\mathbb{1}$ and $\mathbb{2}$.

PROOF. Recall that $\text{Cat}(\mathbb{1}, -) \cong \text{ob}$ and $\text{Cat}(\mathbb{2}, -) \cong \text{mor}$. That is, $\mathbb{1}$ represents the functor taking a small category to its set of objects, while $\mathbb{2}$ represents the functor taking a small category to its set of morphisms.

The functor $0: \mathbb{1} \rightarrow \mathbb{2}$ selects the object $0 \in \text{ob } \mathbb{2}$. The induced natural transformation $\text{Cat}(\mathbb{2}, -) \Rightarrow \text{Cat}(\mathbb{1}, -)$ is given by precomposition with 0 . Interpreting $f \in \text{Cat}(\mathbb{2}, \mathbb{C})$ as a morphism in \mathbb{C} , this precomposition takes f to its domain. That is, precomposition with 0 corresponds to the natural transformation $\text{dom}: \text{mor} \Rightarrow \text{ob}$ that takes morphisms to their domains.

In an analogous way, the functor $1: \mathbb{1} \rightarrow \mathbb{2}$ corresponds to the natural transformation $\text{cod}: \text{mor} \Rightarrow \text{ob}$ that takes morphisms to their codomains.

The unique functor $!: \mathbb{2} \rightarrow \mathbb{1}$ corresponds to the natural transformation $\text{Cat}(\mathbb{1}, -) \Rightarrow \text{Cat}(\mathbb{2}, -)$ given by precomposition with this functor. This induces the natural transformation $1: \text{ob} \Rightarrow \text{mor}$ taking objects c to their identity morphisms 1_c .

EXERCISE 2.1.ii. Prove that if $F: \mathbf{C} \rightarrow \mathbf{Set}$ is representable, then F preserves monomorphisms, i.e., sends every monomorphism in \mathbf{C} to an injective function. Use the contrapositive to find a covariant set-valued function defined on your favorite concrete category that is not representable.

PROOF. If $F: \mathbf{C} \rightarrow \mathbf{Set}$ is representable, we have, for some object $c \in \mathbf{C}$, a natural isomorphism $\eta: F \Rightarrow \mathbf{C}(c, -)$. We can represent η by the following commutative diagram, for a morphism $f: x \rightarrow y$. We note that $\mathbf{C}(c, -)(f) = f_*$, where f_* is post-composition with f .

$$\begin{array}{ccc} Fx & \xrightarrow{Ff} & Fy \\ \eta_x \downarrow & & \downarrow \eta_y \\ \mathbf{C}(c, x) & \xrightarrow{f_*} & \mathbf{C}(c, y) \end{array}$$

Since this diagram commutes, we have that $\eta_y Ff = f_* \eta_x$. Also, since η_y is an isomorphism, we know that $Ff = \eta_y^{-1} f_* \eta_x$. Now, suppose f is a monomorphism. This means that f_* is injective. We know that η_x and η_y^{-1} are injective by the definition of natural isomorphism. So Ff is injective, as it is a composition of injective morphisms. So we see that F preserves monomorphisms.

Now, we note that the contrapositive of this statement says that for a functor $F: \mathbf{C} \rightarrow \mathbf{Set}$, if Ff is not injective for a monomorphism f , then F is not representable. Consider the category \mathbf{C}_* whose objects and morphisms are $A = \{0, 1\}$ and $B = \{0, 1, 2\}$ and $\{1_A, 1_B, f\}$ respectively, where $f: A \rightarrow B$ is defined by $f(0) = 0$ and $f(1) = 1$. (This category and morphism was previously presented and discussed in exercise 1.6.v.) Because of the size of our category, we know that $fh = fk$ implies that $h = k = 1_A$, so f is a monomorphism. But if we consider the functor $F_*: \mathbf{C}_* \rightarrow \mathbf{Set}$ that includes \mathbf{C}_* in \mathbf{Set} , we see that $F_*f = f$ is not injective. So by the contrapositive of the statement previously proven, F_* is not representable. \square

EXERCISE 2.1.iii. Suppose $F: \mathbf{C} \rightarrow \mathbf{Set}$ is equivalent to $G: \mathbf{D} \rightarrow \mathbf{Set}$ in the sense that there is an equivalence of categories $H: \mathbf{C} \rightarrow \mathbf{D}$ so that GH and F are naturally isomorphic.

- (i) If G is representable, then is F representable?
- (ii) If F is representable, then is G representable?

Before we begin the main proof, we must prove a lemma:

LEMMA 2.1.1. Suppose we have isomorphic pairs of functors $F, G: \mathbf{C} \rightarrow \mathbf{D}$, $H_0, H_1: \mathbf{D} \rightarrow \mathbf{E}$, and $K_0, K_1: \mathbf{B} \rightarrow \mathbf{C}$ then

$$H_0F \cong H_1G \text{ and } FK_0 \cong GK_1.$$

To prove this consider an object $c \in \text{ob } \mathbb{C}$, then we have the isomorphism $\alpha_c: Fc \rightarrow Gc$ such that α is the natural transformation between F and G . Let $\beta: H_0 \rightarrow H_1$ be a natural isomorphism. Then we have the commutative diagram.

$$\begin{array}{ccc} H_0Fc & \xrightarrow{H_0\alpha_c} & H_0Gc \\ \beta_{Fc} \downarrow & \searrow \gamma_c & \downarrow \beta_{Gc} \\ H_1Fc & \xrightarrow{H_1\alpha_c} & H_1Gc \end{array}$$

Since functors preserve isomorphisms and β is a natural isomorphism, then every morphism in the diagram is an isomorphism. Thus $H_0Fc \cong H_1Gc$ for all $c \in \text{ob } \mathbb{C}$. Setting $\gamma_c = \beta_{Gc} \cdot H_0\alpha_c$, we can construct the natural isomorphism $\gamma: H_0F \rightarrow H_1G$, and therefore $H_0F \cong H_1G$. The second part of the lemma follows from duality.

PROOF. Now we prove that the answer to part (i) is indeed yes. If G is representable, then $G \cong D(d, -)$ for $d \in \text{ob } \mathbb{D}$. By our lemma, $F \cong GH \cong D(d, -)H$. Since H is an equivalence of categories, H is essentially surjective, meaning there is a $c \in \text{ob } \mathbb{C}$ such that $Hc \cong d$. For such a c we want to show that

$$D(d, -)H \cong C(c, -).$$

For any $c' \in \text{ob } \mathbb{C}$, we want to show that a function $f_{c'}: C(c, c') \rightarrow D(d, Hc')$ defined as

$$f_{c'}(h) = Hh \cdot \pi,$$

where $\pi: d \rightarrow Hc$ is an isomorphism, is a bijection. To show injectivity, suppose for $h, k \in C(c, c')$, $f_{c'}(h) = f_{c'}(k)$. Then, $Hh \cdot \pi = Hk \cdot \pi$. Since π is isomorphic, we have that $Hh = Hk$. Since H is an equivalence of categories, H is a fully faithful functor, thus $h = k$. To show surjectivity, take $l \in D(d, Hc')$ and compose on the right with π^{-1} . Then we get morphism $l \cdot \pi^{-1}: Hc \rightarrow Hc'$. Since H is full, there exists $m \in C(c, c')$ such that $Hm = l \cdot \pi^{-1}$. Right composing with π results in $Hm \cdot \pi = l$, thus confirming surjectivity. A function $f_{c'}$ for all $c' \in \text{ob } \mathbb{C}$ is a bijection. All of the functions $f_{c'}$ form a natural isomorphism $f: C(c, -) \rightarrow D(d, -)H$ showing that $D(d, -)H \cong C(c, -)$. Thus $F \cong C(c, -)$, showing that F is representable.

Now we prove that the answer to part (ii) is also yes. If F is representable, then $F \cong C(c, -)$ for $c \in \text{ob } \mathbb{C}$. Thus, $C(c, -) \cong F \cong GH$. Since H is an equivalence of categories, there exists a functor $H': \mathbb{D} \rightarrow \mathbb{C}$ such that $HH' \cong 1_{\mathbb{D}}$ and $H'H \cong 1_{\mathbb{C}}$. By our lemma, $C(c, -)H' \cong FH' \cong GHH' \cong G$. Since H' is an equivalence of categories, H' is essentially surjective, meaning there is a $d \in \text{ob } \mathbb{D}$ such that $H'd \cong c$. For such a d we want to show that

$$C(c, -)H' \cong D(d, -).$$

For any $d' \in \text{ob } \mathbb{D}$, we want to show that a function $g_{d'}: D(d, d') \rightarrow C(c, H'd')$ defined as

$$g_{d'}(h) = H'h \cdot \phi$$

where $\phi: c \rightarrow H'd$ is an isomorphism, is a bijection. To show injectivity, suppose for $h, k \in D(d, d')$, $g_{d'}(h) = g_{d'}(k)$. Then, $H'h \cdot \phi = H'k \cdot \phi$. Since ϕ is isomorphic, we have

that $H'h = H'k$. Since H' is an equivalence of categories, H' is a fully faithful functor, thus $h = k$. To show surjectivity, take $l \in C(c, H'd')$ and compose on the right with ϕ^{-1} . Then we get morphism $l \cdot \phi^{-1}: H'd \rightarrow H'd'$. Since H' is full, there exists $m \in D(d, d')$ such that $H'm = l \cdot \phi^{-1}$. Right composing with ϕ results in $H'm \cdot \phi = l$, hence $f_{c'}$ is surjective. A function $g_{d'}$ for all $d' \in \text{ob } D$ is a bijection. All of the functions $g_{d'}$ form a natural isomorphism $g: D(d, -) \rightarrow C(c, -)H'$ showing that $C(c, -)H' \cong D(d, -)$. Therefore since $G \cong D(d, -)$, G is representable.

The dual cases of (i) and (ii) follow from changing C and D to their respective opposite category. \square

EXERCISE 2.1.iv. A functor F defines a **subfunctor** of G if there is a natural transformation $\alpha: F \Rightarrow G$ whose components are monomorphisms. In the case of $G: \mathbf{C}^{\text{op}} \rightarrow \mathbf{Set}$, a subfunctor is given by a collection of subsets $Fc \subseteq Gc$ so that each $Gf: Gc \rightarrow Gc'$ restricts to a function $Ff: Fc \rightarrow Fc'$. Characterize those subsets that assemble into a subfunctor of the representable functor $C(-, c)$.

PROOF. First let us clarify what the exercise is actually asking us to do. For some $c \in \text{ob } C$, we want to choose subsets $Fd \subseteq C(d, c)$ for every $d \in \text{ob } C$, such that:

- F is a subfunctor of $C(-, c)$; that is, for every $f: d' \rightarrow d \in C$, the following commutes for some monomorphisms ι', ι .

$$\begin{array}{ccc} Fd & \xrightarrow{\iota} & C(d, c) \\ Ff \downarrow & & \downarrow - \circ f \\ Fd' & \xrightarrow{\iota'} & C(d', c) \end{array}$$

- The function $- \circ f: C(d, c) \rightarrow C(d', c)$ restricts to Ff ; that is, $(- \circ f)(g) = Ff(g)$ for all $g \in Fd$.

Notice that since every $Fd \subseteq C(d, c)$, we automatically have an inclusion morphism from Fd to $C(d, c)$. Since every Fd and $C(d, c)$ are sets, this morphism is trivially monic. So let $\iota: Fd \rightarrow C(d, c)$ in the diagram be the inclusion of Fd into $C(d, c)$ (and define ι' similarly.)

In order for this diagram to commute, for any $g \in Fd$, $(- \circ f)\iota g$ (going along the top) must be equal to $\iota' Ff g$ (going along the bottom). But ι and ι' represent inclusion, so $\iota' Ff g = Ff g$ and $\iota g = g$. So for the diagram to commute, it must be the case that $(- \circ f)g = Ff g$ for any $g \in Fd$; in other words Ff must equal $(- \circ f)$ when applied to elements of Fd . But this is the same as saying that $(- \circ f)$ restricts to Ff ! So the first and second conditions are equivalent – in order for F to be a subfunctor of $C(-, c)$, for any $f: d' \rightarrow d \in C$, $Ff: Fd \rightarrow Fd'$ must be exactly the restriction of $(- \circ f)$ to Fd .

Therefore it must be the case that for every $g: d \rightarrow c \in Fd, f: d' \rightarrow d \in C$, $Ff(g) = (- \circ f)g = gf$. But in order for this to be possible, gf must always be in Fd' independent of the choice of g and f . On the other hand, if that is the case, than obviously $(- \circ f)$ is defined in Fd' for all $f: d' \rightarrow d$; so the restriction of $(- \circ f)$ to Fd – that is to

say, Ff – is defined for every f ! So we can always create a subfunctor F if Fd and Fd' fulfill this condition (for every Fd'), and we cannot create a subfunctor if they do not. More formally:

A family of subsets $\{Fd \subseteq C(d, c) \mid d \in \text{ob } C\}$ can be assembled into a subfunctor F of $C(-, c)$ if and only if: For every $d' \in C$, every $f: d' \rightarrow d \in C$ and every $g: d \rightarrow c \in Fd$, $gf \in Fd'$. So this condition characterizes all of the subsets Fd requested by the exercise. \square

EXERCISE 2.1.v. The functor of Example 2.1.5(xi) that sends a category to its collection of isomorphisms is a subfunctor of the functor of Example 2.1.5(x) that sends a category to its collection of morphisms. Define a functor between the representing categories $\mathbb{1}$ and $\mathbb{2}$ that induces the corresponding monic natural transformation between these representable functors.

PROOF. Recall that $\mathbb{1}$ and $\mathbb{2}$ are defined as

$$\begin{array}{c} \circlearrowleft \\ A \end{array} \begin{array}{c} \xrightarrow{f} \\ \xleftarrow{g} \end{array} \begin{array}{c} \circlearrowright \\ B \end{array} \quad \text{and} \quad \begin{array}{c} \circlearrowleft \\ 0 \end{array} \xrightarrow{h} \begin{array}{c} \circlearrowright \\ 1 \end{array}$$

respectively. We need to construct a functor $F: \mathbb{2} \rightarrow \mathbb{1}$. Since functors must preserve isomorphisms, there are only a few reasonable options. Define F as: $F(0) = A$, $F(1) = B$, $F(1_0) = 1_A$, $F(1_1) = 1_B$, and $F(h) = f$. Let $\iota: \text{iso} \Rightarrow \text{mor}$ be defined by precomposition by F , that is $F \mapsto F\iota$. This map is a subfunctor of the functor we get from the Yoneda lemma

$$\text{iso} \simeq \text{Cat}(\mathbb{1}, -) \xrightarrow{\iota_*} \text{Cat}(\mathbb{2}, -) \simeq \text{mor}.$$

Also ι is clearly monic since it is an inclusion map. \square

2.2 The Yoneda lemma

THEOREM 2.2.1 (Yoneda Lemma). *For any functor $F: \mathbf{C} \rightarrow \mathbf{Set}$, whose domain \mathbf{C} is locally small and any object $c \in \mathbf{C}$, there is a bijection*

$$\mathrm{Hom}(\mathbf{C}(c, -), F) \cong Fc$$

that associates a natural transformation $\alpha: \mathbf{C}(c, -) \Rightarrow F$ to the element $\alpha_c(1_c) \in Fc$. Moreover, this correspondence is natural in both c and F .

In the theorem above, $\mathrm{Hom}(\mathbf{C}(c, -), F)$ is the collection of natural transformations from $\mathbf{C}(c, -)$ to F – a set if \mathbf{C} is small, and a set in a larger universe if \mathbf{C} is large.

EXERCISE 2.2.i. State and prove the dual to Theorem 2.2.4, characterizing natural transformations $\mathbf{C}(-, c) \Rightarrow F$ for a contravariant functor $F: \mathbf{C}^{\mathrm{op}} \rightarrow \mathbf{Set}$.

Here is the dual statement:

For any contravariant functor $F: \mathbf{C}^{\mathrm{op}} \rightarrow \mathbf{Set}$, whose domain \mathbf{C} is locally small and any object $c \in \mathbf{C}$, there is a bijection

$$\mathrm{Hom}(\mathbf{C}(-, c), F) \cong Fc$$

that associates a natural transformation $\alpha: \mathbf{C}(-, c) \Rightarrow F$ to the element $\alpha_c(1_c) \in Fc$. Moreover, this correspondence is natural in both c and F .

PROOF. To prove this, first note that if \mathbf{C} is locally small, then so is \mathbf{C}^{op} since then $\mathbf{C}^{\mathrm{op}}(x, y) = \mathbf{C}(y, x)$ is a set for all $x, y \in \mathrm{ob} \mathbf{C}$. So, we may apply Theorem 2.2.4 to $F: \mathbf{C}^{\mathrm{op}} \rightarrow \mathbf{Set}$. This gives us a natural bijection

$$\mathrm{Hom}(\mathbf{C}^{\mathrm{op}}(c, -), F) \cong Fc$$

via the same formula. All that is left to note is that $\mathbf{C}^{\mathrm{op}}(c, -) = \mathbf{C}(-, c)$, proving the statement above. \square

Actually, this corresponds to the version of the Yoneda Lemma that we proved in class. We showed in class that if \mathbf{C} is a locally small U -category for some universe U and V is a universe such that $U = V$ if \mathbf{C} is small and $U \in V$ if \mathbf{C} is large, then the functors

$$\mathbf{C}^{\mathrm{op}} \times U\text{-Set}^{\mathbf{C}^{\mathrm{op}}} \rightarrow V\text{-Set}$$

taking an object (c, F) to $\mathrm{Hom}(\mathbf{C}(-, c), F)$ in one case or to Fc in the other are isomorphic functors. Arguing as above, we could replace \mathbf{C} by \mathbf{C}^{op} and use that $(\mathbf{C}^{\mathrm{op}})^{\mathrm{op}} = \mathbf{C}$ and that $\mathbf{C}^{\mathrm{op}}(-, c) = \mathbf{C}(c, -)$ to obtain that the functors

$$\mathbf{C} \times U\text{-Set}^{\mathbf{C}} \rightarrow V\text{-Set}$$

taking an object (c, F) to $\mathrm{Hom}(\mathbf{C}(c, -), F)$ and to Fc respectively are isomorphic. This corresponds to the statement in Theorem 2.2.4.

EXERCISE 2.2.ii. Explain why the Yoneda lemma does not dualize to classify natural transformations from an arbitrary set-valued functor to a represented functor.

In the argument in Exercise 2.2.i, we replace \mathbf{C} by \mathbf{C}^{op} changing the directions of the morphisms, but not the direction of natural transformations. That is a reason based on the argument given.

But, here is an example showing that there is no such lemma with natural transformations from F to $\mathbf{C}(c, -)$. Let $\mathbf{C} = \mathbf{Set}$, $F = 1_{\mathbf{Set}}$ and $c = \emptyset$. Then $\mathbf{Set}(\emptyset, -)$ is a constant functor taking every set x to $\{\emptyset\}$ and every $f: x \rightarrow y$ to the identity function for this set. There is a unique natural transformation $\alpha: 1_{\mathbf{Set}} \Rightarrow \mathbf{Set}(\emptyset, -)$. This is not in bijection with $1_{\mathbf{Set}}\emptyset = \emptyset$.

EXERCISE 2.2.iii. As discussed in Section 2.2, diagrams of shape ω are determined by a countably infinite family of objects and a countable infinite sequence of morphisms. Describe the Yoneda embedding $y: \omega \hookrightarrow \mathbf{Set}^{\omega^{\text{op}}}$ in this manner (as a family of ω^{op} -indexed functors and natural transformations). Prove directly, without appealing to the Yoneda lemma, that y is full and faithful.

PROOF. It is reasonable to identify the category ω with the ordinal ω . Hence the objects of ω are the elements of ω and the morphisms of ω are ordered pairs of objects where the second element is greater than or equal to the first. For example, we have elements n and m with a morphism $n \leq m$.

Now we describe the action of y on objects of ω . In this light, for a given n in ω , the functor $\omega(-, n)$ takes an object m and maps it to $\{m \leq n\}$ if this is a true statement, and the empty set otherwise. Similarly, given an arrow $p \leq q$, $\omega(-, n)$ re-imagines this as a function that pre-composes with $q \leq n$ to give $p \leq n$. This is just the unique function between the singleton sets $\{q \leq n\}$ and $\{p \leq n\}$. Note that if p is greater than n (along with q by transitivity), then both p and q have been mapped to the empty set and rather than an arrows $p \leq q$, $q \leq n$, and $p \leq n$ we have the empty map, which all compose as we want them. If only q is greater than n , then $p \leq n$ becomes a nontrivial map under our functor while $q \leq n$ is still the empty map. This is not a problem because the empty map is absorbing with respect to pre-composition.

$$0 \leq n \longleftarrow 1 \leq n \longleftarrow 2 \leq n \longleftarrow \cdots \longleftarrow n \leq n \longleftarrow \emptyset \longleftarrow \cdots$$

Similarly, y takes a morphism $m \leq n$ to a map from $\omega(-, m)$ to $\omega(-, n)$ defined as follows. As shown above, an object of $\omega(-, m)$ is $\{p \leq m\}$ or the empty set. This time we post-compose $p \leq m$ with $m \leq n$ to get $p \leq n$ (or the empty set analogously to the above argument). Concretely $m \leq n$ is a collection of maps of the form $\{(p \leq m), (p \leq n)\}$ where either the second or both symbols may be the empty set.

$$\begin{array}{cccccccc} 0 \leq n \longleftarrow & 1 \leq n \longleftarrow & \cdots \longleftarrow & m \leq n \longleftarrow & \cdots \longleftarrow & n \leq n \longleftarrow & \emptyset \longleftarrow & \cdots \\ \uparrow (m \leq n)(0 \leq m) & \uparrow (m \leq n)(1 \leq m) & & \uparrow (m \leq n)(m \leq m) & & \uparrow (m \leq n)\emptyset & & \\ 0 \leq m \longleftarrow & 1 \leq m \longleftarrow & \cdots \longleftarrow & m \leq m \longleftarrow & \cdots \longleftarrow & \emptyset \longleftarrow & \cdots & \end{array}$$

Note that this functor is immediately faithful because our domain category is a preorder. To see that it is full, note that every object in \mathbf{Set} that objects of ω map on to are either singleton sets or the empty set. Cardinal arithmetic gives us three cases to consider 1^1 , 1^0 , and 0^0 . In no case is it possible for there to be a map in the homset that our functor missed. \square

EXERCISE 2.2.iv. Prove the following strengthening of Lemma 1.2.3, demonstrating the equivalence between an isomorphism in a category and a representable isomorphism between the corresponding co- or contravariant functors: the following are equivalent:

- (i) $f: x \rightarrow y$ is an isomorphism in \mathbf{C} .
- (ii) $f_*: \mathbf{C}(-, x) \Rightarrow \mathbf{C}(-, y)$ is a natural isomorphism.
- (iii) $f^*: \mathbf{C}(y, -) \Rightarrow \mathbf{C}(x, -)$ is a natural isomorphism.

PROOF. We prove this as a consequence of the Yoneda embedding theorem. We note that by the Yoneda embedding theorem, we have an a fully faithful functor from \mathbf{C} to $\mathbf{Set}^{\mathbf{C}^{\text{op}}}$ and from \mathbf{C}^{op} to $\mathbf{Set}^{\mathbf{C}}$ and that this means that there are bijections between $\mathbf{C}(x, y)$ and $\mathbf{Set}^{\mathbf{C}^{\text{op}}}(\mathbf{C}(-, x), \mathbf{C}(-, y))$ and between $\mathbf{C}^{\text{op}}(x, y)$ and $\mathbf{Set}^{\mathbf{C}}(\mathbf{C}(y, -), \mathbf{C}(x, -))$. To see that (i) implies (ii) and (iii), we note that if there exists an isomorphism $f: x \rightarrow y$, there exists at least one natural transformation $\mathbf{C}(-, x) \Rightarrow \mathbf{C}(-, y)$ and $\mathbf{C}(y, -) \Rightarrow \mathbf{C}(x, -)$ by the bijections previously noted. We also see that the components of f_* and f^* are defined by post and pre-composition with f , respectively, and that post and pre composition by an isomorphism creates another isomorphism. So all components of f_* and f^* are isomorphisms and therefore f_* and f^* are natural isomorphisms.

Now, we show that (ii) implies (i) and that (iii) implies (i). To do this, we recall that full and faithful functors create isomorphisms. Since we have that $\mathbf{C}(-, x)$ and $\mathbf{C}(-, y)$ are isomorphic by f_* , we know that x and y are also isomorphic by f , since f_* is the image of f . Likewise, if $\mathbf{C}(y, -)$ and $\mathbf{C}(x, -)$ are isomorphic by f^* , then so are x and y by f , since f^* is the image of f . So we have show that both (ii) and (iii) independently imply (i) and that shows the equivalence of all three statements.

EXERCISE 2.2.v. By the Yoneda Lemma, natural endomorphisms of the covariant power set functor $P: \mathbf{Set}^{\text{op}} \rightarrow \mathbf{Set}$ correspond bijectively to endomorphisms of its representing object $\Omega = \{0, 1\}$. Describe the natural endomorphisms of P that correspond to each of the four elements of $\text{hom}(\Omega, \Omega)$. Do these functions induce natural endomorphisms of the covariant functor?

PROOF. The Yoneda Lemma gives the isomorphism $\text{hom}(\mathbf{C}(-, c), F) \cong Fc$, for any object c and contravariant functor F into \mathbf{Set} . Setting c to be Ω gives us an isomorphism $\Psi: F\Omega \rightarrow \text{hom}(\mathbf{C}(-, \Omega), F)$; such that for any $g \in F\Omega$ we obtain a natural transformation $\Psi(g): \mathbf{C}(-, \Omega) \Rightarrow F$. For any set Z we can also look at a particular leg of this natural transformation, $\Psi(g)_Z: \mathbf{C}(Z, \Omega) \rightarrow FZ$; which takes each $f: Z \rightarrow \Omega$ to $Ff(g)$. Now let

F be $\text{Set}(-, \Omega)$. This means that $\Psi(g)_Z : \mathbf{C}(Z, \Omega) \rightarrow \mathbf{C}(Z, \Omega)$ takes each $f : Z \rightarrow \Omega$ to $\mathbf{C}(f)(g) = f^*g = gf$.

Recall that f and gf both correspond bijectively to elements of PZ under the bijection ϕ defined in Proposition 2.1.6(i) that takes functions to the preimage of $1 \in \Omega$ under those functions. So the endomorphism $\Psi(g)_Z$ corresponds to the endomorphism $h_Z : PZ \rightarrow PZ$ that takes ϕf to $\phi(gf)$, for all $f : Z \rightarrow \Omega$. That is to say, h_Z takes the set $\{x \in Z \mid f(x) = 1\}$ to the set $\{x \in Z \mid gf(x) = 1\}$. Generalizing for all sets Z , we have a bijection that takes $\Psi(g) : \mathbf{C}(-, \Omega) \Rightarrow \mathbf{C}(-, \Omega)$ to $h : P \Rightarrow P$, such that h takes $\{x \in Z \mid f(x) = 1\}$ to $\{x \in Z \mid gf(x) = 1\}$, for all sets Z .

- Let h be the identity endomorphism 1_P . For any set Z and function $f : Z \rightarrow \Omega$, $\phi(gf) = 1_P \phi(f) = 1_P \{x \in Z \mid f(x) = 1\} = \{x \in Z \mid f(x) = 1\}$. So $gf(x) = f(x)$ for all functions $f : Z \rightarrow \Omega$ and $x \in Z$, and this can only be the case if $g = 1_\Omega$.
- Let h be the complement endomorphism Comp , which sends each $A \in PZ$ to $Z \setminus A$. For any set Z and function $f : Z \rightarrow \Omega$, $\phi(gf) = \text{Comp} \phi(f) = \text{Comp} \{x \in Z \mid f(x) = 1\} = \{x \in Z \mid f(x) \neq 1\}$. So $gf(x) \neq f(x)$ for all functions $f : Z \rightarrow \Omega$ and $x \in Z$, which means g must be the transposition morphism $\tau : \Omega \rightarrow \Omega$; which sends 1 to 0 and 0 to 1.
- Let h be the constant endomorphism c_\emptyset that sends all $A \in PZ$ to *emptyset*. For any set Z and function $f : Z \rightarrow \Omega$, $\phi(gf) = c_\emptyset(f) = c_\emptyset \{x \in Z \mid f(x) = 1\} = \emptyset$. So $gf(x) = 0$ for all functions $f : Z \rightarrow \Omega$ and $x \in Z$, and this can only be the case if $g = c_0 : \Omega \rightarrow \Omega$; the constant morphism that sends both 0 and 1 to 0.
- Let h be the constant endomorphism c_P that sends all $A \in PZ$ to Z . For any set Z and function $f : Z \rightarrow \Omega$, $\phi(gf) = c_P \phi(f) = c_P \{x \in Z \mid f(x) = 1\} = Z$. So $gf(x) = 1$ for all functions $f : Z \rightarrow \Omega$ and $x \in Z$, and this can only be the case if $g = c_1 : \Omega \rightarrow \Omega$; the constant morphism that sends both 0 and 1 to 1.

So 1_P corresponds to 1_Ω , Comp corresponds to τ , c_\emptyset corresponds to c_0 , and c_P corresponds to c_1 .

Of the four different functions h above, the only two that are natural endomorphisms of the *covariant* power set functor P are the first and third.

The identity is obviously a natural endomorphism. But, so is the constant endomorphism c_\emptyset . Indeed in this case for any function $f : eX \rightarrow Y$ and any $A \in P(X)$,

$$P(f)h_X(A) = P(f)(\emptyset) = \emptyset = h_Y P(f)(A).$$

But, h is not a natural endomorphism in the second and fourth cases. For example, let X be any nonempty set and $f : \emptyset \rightarrow X$ be the unique such function. If $h = \text{Comp}$, then $P(f)h_\emptyset(\emptyset) = P(f)(\emptyset) = \emptyset$ while $h_X P(f)(\emptyset) = h_X(\emptyset) = X$. So, $P(f)h_\emptyset \neq h_X P(f)$ and h is *not* a natural endomorphism. The very same computation shows that if h is the constant function sending every element of $P(Z)$ to Z , then for $f : \emptyset \rightarrow X$, $P(f)h_\emptyset \neq h_X P(f)$ and h is not a natural endomorphism. \square

EXERCISE 2.2.vi. Do there exist any non-identity natural endomorphisms of the category of spaces? That is, does there exist any family of continuous maps $X \rightarrow X$, defined for all spaces X and not all of which are identities, that are natural in all maps in the category Top ?

PROOF. Consider the topological space with one element $\{x\}$. Suppose α is a natural endomorphism of 1_{Top} , then for any topological space Y we have the following commutative diagram:

$$\begin{array}{ccc} \{x\} & \xrightarrow{\quad} & Y \\ \downarrow \alpha_{\{x\}} & & \downarrow \alpha_Y \\ \{x\} & \xrightarrow{\quad} & Y \end{array}$$

where $f_y(x) = y$ for all $y \in Y$. $\alpha_{\{x\}} = 1_{\{x\}}$ trivially, thus from the commutative diagram we get that $f_y = \alpha_Y \cdot f_y$. From this, it is clear that $y = \alpha_Y(y)$ for all $y \in Y$. Thus α_Y is the identity function on Y . Therefore, the only natural endomorphism of 1_{Top} is the identity natural endomorphism. \square

We have shown for Top , that its identity functor only has the identity natural transformation. For the rest of the paper, we will generalize our result above to a concrete category \mathbf{C} .

DEFINITION 2.2.2. Suppose some \mathbf{C} has a terminal object ω , we definition the following three terms

1. any morphism $f: \omega \rightarrow c$ for $c \in \text{ob } \mathbf{C}$ is called a **global element** of c
2. \mathbf{C} is **well-pointed** if and only if for any two morphisms $f, g: c \rightarrow d$ of \mathbf{C} , if $f \cdot h = g \cdot h$ for every global element h of c , then $f = g$
3. We will call an object α_s **weakly initial** if and only if $\mathbf{C}(\alpha_s, c)$ contains at most one morphism for all objects c

Now we will show the following:

LEMMA 2.2.3. *If \mathbf{C} has a terminal object ω which is not weakly initial, is well pointed and all of its objects that aren't weakly initial have global elements, then the functor $1_{\mathbf{C}}$ only has the identity natural endomorphism.*

PROOF. Suppose β is a natural endomorphism of $1_{\mathbf{C}}$. apply the natural endomorphism to $f: \omega \rightarrow c$ where c is not weakly initial. This results in the diagram

$$\begin{array}{ccc} \omega & \xrightarrow{\quad f \quad} & c \\ \beta_\omega \downarrow & & \downarrow \beta_c \\ \omega & \xrightarrow{\quad f \quad} & c \end{array}$$

Thus $f \cdot \beta_\omega = \beta_c \cdot f$. $\beta_\omega = 1_\omega$ since ω has a unique endomorphism, so we get $1_c \cdot f = \beta_c \cdot f$. This holds for every global element of c due to naturality. Since \mathbf{C} is well-pointed, $\beta_c = 1_c$. Since every non weakly initial object c has a global element, then $\beta_c = 1_c$. For weakly initial object α_s , it has a unique endomorphism by definition. So, $\beta_{\alpha_s} = 1_{\alpha_s}$. Thus β is the identity natural endomorphism on $1_{\mathbf{C}}$. Therefore, $1_{\mathbf{C}}$ has only the identity natural endomorphism. \square

From now on we will be working with a concrete category \mathbf{C} with terminal object ω , which is not weakly initial, where $U: \mathbf{C} \rightarrow \mathbf{Set}$ is a faithful functor. We will generalize the last two properties in the definition above using the following lemma:

LEMMA 2.2.4. *Suppose we have concrete category \mathbf{C} with corresponding faithful functor U and terminal object ω which is not weakly initial, then the following holds:*

1. *If U is a subfunctor of $\mathbf{C}(\omega, -)$ then $\mathbf{C}(\omega, -) \cong U$*
2. *If $\mathbf{C}(\omega, -) \cong U$ then \mathbf{C} is well-pointed, all not weakly initial objects of \mathbf{C} have global elements*

Before we prove this, we will prove another lemma

LEMMA 2.2.5. *Suppose we have concrete category \mathbf{C} with corresponding faithful functor U , a terminal object ω which is not weakly initial and α_s is a weakly initial object in \mathbf{C} , we have the following properties:*

1. *U reflects weakly initial objects*
2. *$\mathbf{C}(\omega, \alpha_s) = \emptyset$*
3. *$\mathbf{Set}(\{x\}, A) \cong A$ for all sets A*
4. *\mathbf{Set} is well-pointed*
5. *$\mathbf{C}(\omega, -)$ has a unique endofunctor*

PROOF. Part 1 follows from U being faithful. The only weakly initial set is the empty set. If there exist some object c in \mathbf{C} such that $Uc = \emptyset$, then for any object d in \mathbf{C} , there is an injection between $\mathbf{C}(c, d)$ and $\mathbf{Set}(\emptyset, Ud)$. Since $\mathbf{Set}(\emptyset, Ud)$ has exactly one element, then $\mathbf{C}(c, d)$ has at most one element. Thus c is weakly initial.

For Part 2, suppose $f \in \mathbf{C}(\omega, \alpha_s)$, then f is an isomorphism since ω and α_s have unique endomorphisms. Then $\mathbf{C}(\omega, -) \cong \mathbf{C}(\alpha_s, -)$ making ω a weakly initial object, which is a contradiction. Therefore, $\mathbf{C}(\omega, \alpha_s) = \emptyset$.

For part 3, we can define a function from $\mathbf{Set}(\{x\}, A)$ to A by taking a function g from $\mathbf{Set}(\{x\}, A)$ and mapping it to $g(x)$. This function is clearly injective since each function in $\mathbf{Set}(\{x\}, A)$ only has one element in its domain, and is clearly surjective since each element y in A corresponds to the function mapping x to y . Thus we have a bijection, therefore $\mathbf{Set}(\{x\}, A) \cong A$.

For part 4, take functions $f, g: A \rightarrow B$ and suppose $f \cdot h = g \cdot h$ for every global element h of A . By the proof in part 3, this means that $f(x) = g(x)$ for all x in A . Thus $f = g$. Therefore, \mathbf{Set} is well-pointed.

For part 5 consider an endofunctor γ of $\mathbf{C}(\omega, -)$, which gives the following commutative diagram for global element f of non weakly initial object c :

$$\begin{array}{ccc} \mathbf{C}(\omega, \omega) & \xrightarrow{f_*} & \mathbf{C}(\omega, c) \\ \gamma_\omega \downarrow & & \downarrow \gamma_c \\ \mathbf{C}(\omega, \omega) & \xrightarrow{f_*} & \mathbf{C}(\omega, c) \end{array}$$

taking the unique endomorphism of ω one gets that $f = \gamma_c(f)$. Thus γ_c is the identity morphism. for weakly initial object α_s , $\mathbf{C}(\omega, \alpha_s) = \emptyset$, thus $\gamma_{\alpha_s} = 1_\emptyset$. Thus γ is the identity natural endomorphism. Therefore, $\mathbf{C}(\omega, -)$ has a unique natural endomorphism. \square

Now we will prove lemma 2.2.3

PROOF. Part 1: By Yoneda lemma, $\text{Hom}(\mathbf{C}(\omega, -), U) \cong U\omega$. Since U reflects weakly initial objects, there is at least one natural transformation δ from $\mathbf{C}(\omega, -)$ to U . By our assumption, there is a monic natural transformation β from U to $\mathbf{C}(\omega, -)$. Since $\mathbf{C}(\omega, -)$ has a unique endomorphism, $\beta \cdot \delta = 1_{\mathbf{C}(\omega, -)}$. This means that β is also epic. Thus every morphism β_c for $c \in \text{ob } \mathbf{C}$ is injective and surjective, and thus bijective. So β is a natural isomorphism. Therefore, $\mathbf{C}(\omega, -) \cong U$.

Part 2: Suppose for $f, g: c \rightarrow d \in \text{mor } \mathbf{C}$ we have that $f \cdot h = g \cdot h$ for every global element h of c . Then $Uf \cdot Uh = Ug \cdot Uh$. Since $U \cong \mathbf{C}(\omega, -)$, $U\omega$ has only one element thus Uh is a global element of Uc . Since we have that $\mathbf{C}(\omega, c) \cong Uc \cong \text{Set}(U\omega, Uc)$, then Uh range over every global element of Uc . Since Set is well pointed, then $Uf = Ug$. Since U is faithful, $f = g$. Therefore, \mathbf{C} is well-pointed.

For any non weakly initial object c of \mathbf{C} , Uc is non-empty since U reflects weakly initial objects. Thus $\mathbf{C}(\omega, c)$ is non empty, thus every non weakly initial object c has a global element. \square

Now let us take an equivalence of categories $T: \mathbf{C} \rightarrow \mathbf{C}$. This is our main result:

THEOREM 2.2.6. *Suppose we have concrete category \mathbf{C} with corresponding faithful functor U and terminal object ω which is not weakly initial. If U is a subfunctor of $\mathbf{C}(\omega, -)$ and $T: \mathbf{C} \rightarrow \mathbf{C}$ is an equivalence of then $\text{Hom}(T, T) \cong \text{Hom}(\mathbf{C}(\omega, -), U)$*

PROOF. Since U is a subfunctor of $\mathbf{C}(\omega, -)$, $U \cong \mathbf{C}(\omega, -)$. By Yoneda Lemma and since U preserves terminal objects, there is a unique natural isomorphism β from $\mathbf{C}(\omega, -)$ to U . Take a natural endomorphism δ from $\text{Hom}(T, T)$. Since T is an equivalence of categories, there exist a functor T_0 such that $T_0 \cdot T \cong 1_{\mathbf{C}}$. define the natural transformation $T_0\delta$ where its components are the functor T_0 applied to the components of δ . The fact that $T_0\delta$ is a natural transformation follows from the naturality of δ and the fact that T_0 is full and faithful. Thus $T_0\delta$ is a natural endomorphism of $T_0 \cdot T$. Since $T_0 \cdot T \cong 1_{\mathbf{C}}$, there exist a natural isomorphism γ from $T_0 \cdot T$ to $1_{\mathbf{C}}$. composing γ and γ^{-1} to $T_0\delta$ gives us $\gamma \cdot T_0\delta \cdot \gamma^{-1}$ which is an endomorphism of $1_{\mathbf{C}}$. We shall refer to $\gamma \cdot T_0\delta \cdot \gamma^{-1}$ as ϵ . We will horizontal composition on β and ϵ to obtain $\beta * \epsilon$. The diagram for the horizontal composition is a follows:

$$\begin{array}{ccc} \mathbf{C}(\omega, c) & \xrightarrow{\mathbf{C}(\omega, \epsilon_c)} & \mathbf{C}(\omega, c) \\ \beta_c \downarrow & \searrow^{(\beta * \epsilon)_c} & \downarrow \beta_c \\ Uc & \xrightarrow{U\epsilon_c} & Uc \end{array}$$

This shows us that $(\beta * \epsilon)_c = U\epsilon_c \cdot \beta_c$. Define a function $t: \text{Hom}(T, T) \rightarrow \text{Hom}(\mathbf{C}(\omega, -), U)$ taking δ to $\beta * \epsilon$. We will show that t is injective. Suppose that there was a δ' such that $\epsilon' = \gamma \cdot T_0\delta' \cdot \gamma^{-1}$ and $\beta * \epsilon = \beta * \epsilon'$. Then, $U\epsilon_c \cdot \beta_c = U\epsilon'_c \cdot \beta_c$. Since β_c is an isomorphism, it is also epic. Thus $U\epsilon_c = U\epsilon'_c$ and also $\epsilon_c = \epsilon'_c$ since U is faithful. Thus $\epsilon = \epsilon'$. Since γ and γ^{-1} are isomorphic, they are both monic and epic, so $T_0\delta = T_0\delta'$. Since T_0 is faithful, $\delta_c = \delta'_c$ for every $c \in \text{ob } \mathbf{C}$. Thus $\delta = \delta'$. So t is an injection from $\text{Hom}(T, T)$ to $\text{Hom}(\mathbf{C}(\omega, -), U)$. Since $\text{Hom}(\mathbf{C}(\omega, -), U)$ has only one element and $\text{Hom}(T, T)$ has

at least one element (the identity natural transformation), t is also surjective. Therefore, $\text{Hom}(T, T) \cong \text{Hom}(C(\omega, -), U)$. \square

An immediate consequence of the theorem is that every equivalence T has only the identity natural transformation.

This completes our generalization of problem 2.2.vi.

EXERCISE 2.2.vii. Use the Yoneda lemma to explain the connection between homeomorphisms of the standard unit interval $I = [0, 1] \subset \mathbb{R}$ and natural automorphisms of the path functor $\mathbf{Path}: \mathbf{Top} \rightarrow \mathbf{Set}$.

PROOF. Viewing the path functor, $F = \mathbf{Path}: \mathbf{Top} \rightarrow \mathbf{Set}$, in light of the Yoneda lemma, there is a bijection $\text{Hom}(\mathbf{Top}(I, -), F) \cong FI$, such that $(\alpha: \mathbf{Top}(I, -) \Rightarrow F) \mapsto \alpha_I(1_I)$, and for $x \in FI$ with $y \in \text{ob}\mathbf{Top}$, $x \mapsto (\psi(x): \mathbf{Top}(I, -) \Rightarrow F)$, with components of the natural transformation $\psi(x)_y: \mathbf{Top}(I, y) \rightarrow Fy$.

Now, for paths in the unit interval, with continuous functions f being mapped to $Ff(x)$, from the Yoneda lemma again, there is a bijection $\text{Hom}(\mathbf{Path}, \mathbf{Path}) \cong \mathbf{Path}(I)$, with $I \mapsto \text{Top}(I, -) = \mathbf{Path}(I)$. The covariant functor $\text{Top}^{op} \rightarrow \mathbf{Set}^{\text{Top}}$ then gives an isomorphism between endomorphisms of the unit interval and natural transformations of the path functor.

The Yoneda embedding theorem shows that this is actually a monoid isomorphism between $\text{Hom}(\mathbf{Path}, \mathbf{Path})$ and $\mathbf{Path}(I) = \text{Top}(I, I)$. This gives an isomorphism between their groups of invertible elements. In the first case, these are the natural automorphisms of \mathbf{Path} . In the second, these are the homeomorphisms of I to itself.

2.3 Universal properties and universal elements

EXERCISE 2.3.i. What are the universal elements for the representations:

1. defining the category $\mathcal{2}$ in Example 2.1.5(x)?
2. defining the Sierpinski space in Example 2.1.6(ii)?
3. defining the Sierpinski space in Example 2.1.6.(iii)?

Definition 2.3.3: A *universal property* of an object $c \in \mathbf{C}$ is expressed by a representable functor F together with a *universal element* $x \in Fc$ that defines a natural isomorphism $\mathbf{C}(c, -) \cong F$ or $\mathbf{C}(-, c) \cong F$, as appropriate, via the Yoneda lemma.

Note that if η is the natural isomorphism from $\mathbf{C}(c, -)$ or $\mathbf{C}(-, c)$ to F , then $x = \eta_c(1_c)$.

1. Example 2.1.5: The following covariant functors are representable.

(x) The functor $\text{mor}: \mathbf{Cat} \rightarrow \mathbf{Set}$ that takes a small category to its set of morphisms is represented by the category $\mathcal{2}$: a functor $\mathcal{2} \rightarrow \mathbf{C}$ is no more and no less than a choice of morphism in \mathbf{C} .

In this sense, the category $\mathcal{2}$ is the *free* or *walking arrow*.

In this case, let f be the unique nonidentity morphism in $\mathcal{2}$. Then the isomorphism $\eta: \mathbf{Cat}(\mathcal{2}, -) \Rightarrow \text{mor}$ is given on an object D of \mathbf{Cat} by $\eta_D: \mathbf{Cat}(\mathcal{2}, D) \rightarrow \text{mor } D$ defined by $\eta_D F = Ff$. Thus, the universal element is $\eta_{\mathcal{2}}(1_{\mathcal{2}}) = 1_{\mathcal{2}}f = f$.

2. Example 2.1.6: The following contravariant functors are representable.

(ii) The functor $O: \mathbf{Top}^{\text{op}} \rightarrow \mathbf{Set}$ that sends a space to its set of open subsets is represented by the *Sierpinski space* S , the topological space with two points, one closed and one open. The natural bijection $\mathbf{Top}(X, S) \cong O(X)$ associates a continuous function $X \rightarrow S$ to the preimage of the open point. This bijection is natural because a composite function $Y \rightarrow X \rightarrow S$ classifies the preimage of the open subset of X under the function $Y \rightarrow X$.

To provide a little more detail, say that $S = \{0, 1\}$ and that the open sets in S are \emptyset , $\{0\}$, and S . Note that these open sets satisfy the axioms of a topology: \emptyset and S are open, the union of any family of open sets is open, and the intersection of any two open sets is open. The closed sets are the complements of the open sets: \emptyset , $\{1\}$, S . By the open point we mean 0, since the singleton set $\{0\}$ is open, and by the closed point we mean 1, since the singleton set $\{1\}$ is closed.

Recall that for two topological space Y and X , $f: Y \rightarrow X$ is continuous (i.e. a morphism in \mathbf{Top}) if for every open set U in X , $f^{-1}(U)$ is open in Y .

In particular, for any continuous function $f: Y \rightarrow S$, $f^{-1}(0) = f^{-1}(\{0\})$ is open in Y . Note that f is completely determined by $f^{-1}(0)$ for any element of $y \in Y$ that is not in $f^{-1}(0)$ we must have that $f(y) = 1$, the only element of S other than 0. Conversely,

if V is an open subset of Y , then we have a continuous function $f_V: Y \rightarrow S$ given by

$$f_V(y) = \begin{cases} 0 & \text{if } y \in V \\ 1 & \text{if } y \notin V. \end{cases}$$

This gives a natural bijection between $\text{Top}(Y, S)$ and $\mathcal{O}(Y)$. That is, we have a natural isomorphism $\eta: \text{Top}(-, S) \Rightarrow \mathcal{O}$ defined by $\eta_Y: \text{Top}(Y, S) \Rightarrow \mathcal{O}(Y)$ defined by $\eta_Y(f) = f^{-1}(\{0\})$.

Now, to the question at hand. We have that the natural isomorphism η maps to $\eta_S(1_S) = 1_S^{-1}(\{0\}) = \{0\}$, the open point of S or, more precisely, the singleton set consisting of the open point of S .

3. (iii) The Sierpinski space also represents the functor $\mathcal{C}: \text{Top}^{\text{op}} \rightarrow \text{Set}$ that sends a space to its set of closed subsets. Composing the natural isomorphisms $\mathcal{O} \cong \text{Top}(-, S) \cong \mathcal{C}$ we see that the closed set and open set functors are naturally isomorphic. The composite natural isomorphism carries an open subset to its complement, which is closed. This recovers the natural isomorphism described in Example 1.4.3(v).

The solution to this problem is essentially the same as the last part. It is worth noting that for topological spaces Y and X , a function $f: Y \rightarrow X$ is continuous if and only if for every closed set A in X , $f^{-1}(A)$ is closed in Y . Indeed, Y is the disjoint union of the inverse image of A and the inverse image of the complement A^c of A , which is open. If f is continuous, then $f^{-1}(A^c)$ is open in Y so that $f^{-1}(A)$ is closed in Y . Conversely, if $f^{-1}(A)$ is closed in Y for every closed set A of X , then for every open set U of X , $f^{-1}(U^c)$ is closed so that $f^{-1}(U)$ is open and f is continuous.

Just as above, we make a natural isomorphism from $\text{Top}(-, S)$ to \mathcal{C} by defining $\epsilon_Y: \text{Top}(Y, S) \rightarrow \mathcal{C}(Y)$ by $\epsilon_Y(f) = f^{-1}(1) = f^{-1}(\{1\})$. Then under the Yoneda correspondence, ϵ maps to $\epsilon_S(1_S) = 1_S^{-1}(\{1\}) = \{1\}$, the closed point of S or, more precisely, the singleton set consisting of the closed point of S .

EXERCISE 2.3.ii. Use the defining universal property of the tensor product to prove that

1. $\mathbb{k} \otimes_{\mathbb{k}} V \cong V$ for any \mathbb{k} vector space V ; and
2. $(U \otimes V) \otimes W \cong U \otimes (V \otimes W)$ for any \mathbb{k} vector spaces U, V , and W .

LEMMA 2.3.1. *The tensor product of two vector spaces V and W is spanned by rank one tensors.*

PROOF. Rank one tensors have the form $\sum_{i=1}^n v_i \otimes w_i$, where v_i and w_i are basis vectors of V and W respectively.¹ These rank one tensors are linearly independent so then can be

¹Every vector space has a basis thanks to the Axiom of Choice. The sketch of the proof involves taking a chain of linearly independent subsets and looking at the union of that chain. The union is still a linearly independent set, and therefore an upper bound for this chain. Since every chain has an upper bound by Zorn's Lemma (which is equivalent to the Axiom of Choice) a maximal linearly independent set exists. Since a basis can be defined a maximal linearly independent subset of a vector space, we have the every vector space has a basis.

found in a some basis B of $V \otimes W$. Suppose there was an element of $V \otimes W$ that is not in the span of the rank one tensors. Call it z . Then $z \cup B$ is still a linearly independent and can be contained in some basis B' . Since a linear maps is completely defined by its action on the basis, we could construct two distinct linear maps that we could factor function $f: V \times W \rightarrow U$ through. This contradicts the uniqueness of the universal property of the tensor product, so the rank one tensors span the tensor product space.

PROOF. We need to show that for a bilinear map f there exists a unique linear map \bar{f} that makes the following diagram commute.

$$\begin{array}{ccc} \mathbb{k} \times V & \xrightarrow{\otimes} & \mathbb{k} \otimes V \\ & \searrow f & \downarrow \bar{f} \\ & & W \end{array}$$

Since $f: \mathbb{k} \times V \rightarrow W$ is bilinear, for any α in \mathbb{k} and v in V we have $f(\alpha, v) = \alpha f(1, v)$. Because \bar{f} is linear if we choose $\bar{f}(\alpha v) = \alpha \bar{f}(v) = \alpha f(1, v)$, this diagram will commute. This mapping is unique since, it holds for all α , we can choose α to be one. Since we have found the unique \bar{f} that makes the above diagram commutes, we can apply the universal property of the tensor product to see that $\mathbb{k} \otimes_{\mathbb{k}} V \cong V$ as desired.

Now we will show $(U \otimes V) \otimes W \cong U \otimes (V \otimes W)$ for any \mathbb{k} vector spaces U, V , and W . For some vector space X let f be a trilinear map $f: U \times V \times W \rightarrow X$. Define $f_w: U \times V \rightarrow X$ to be $f_w(u, v) = f(u, v, w)$. Notice that f_w is a bilinear map from $U \times V$ to X , by the universal property of the tensor product there exists a unique linear map \bar{f}_w that makes the following diagram commute.

$$\begin{array}{ccc} U \times V & \xrightarrow{\otimes} & U \otimes V \\ & \searrow f_w & \downarrow \bar{f}_w \\ & & X \end{array}$$

Define $f_L: (U \otimes V) \times W \rightarrow X$, to be bilinear map. Thus $f_L(z, w) = \bar{f}_w(z \otimes v_i)$ is a linear map and we can apply the universal property again to get the following commutative diagram.

$$\begin{array}{ccc} (U \otimes V) \times W & \xrightarrow{\otimes} & (U \otimes V) \otimes W \\ & \searrow f_L & \downarrow \bar{f}_L \\ & & X \end{array}$$

In a similar fashion define $f^u(v, w): V \times W \rightarrow X$, from $V \times W$ to an arbitrary vector space X where $f^u(v, w) = g(u, v, w)$. Again, by the universal property of the tensor product there exists a unique linear map \bar{f}^u such that the following diagram commutes.

$$\begin{array}{ccc} U \times V & \xrightarrow{\otimes} & U \otimes V \\ & \searrow f^u & \downarrow \bar{f}^u \\ & & X \end{array}$$

Again we can define $f_R : U \times (V \otimes W) \rightarrow X$, where $f_R(u, \sum_{i=1}^t \alpha_i v_i \otimes w_i)$. By the universal property of the tensor product we have the following commutative diagram.

$$\begin{array}{ccc} U \times (V \otimes W) & \xrightarrow{\otimes} & U \otimes (V \otimes W) \\ & \searrow f_R & \downarrow \tilde{f}_R \\ & & X \end{array}$$

Define the maps $w \mapsto \tilde{f}_w$ from W to $\text{Vect}_k(U \otimes V, X)$ and $u \mapsto \tilde{g}_u$ from U to $\text{Vect}_k(V \otimes W, X)$. Since f and g are trilinear and \tilde{f}_w and \tilde{g}_u are linear we have

$$\tilde{f}_{\alpha w_1 + w_2}(u, v) = f(u, v, \alpha w_1 + w_2) = \alpha f(u, v, w_1) + f(u, v, w_2) = \alpha \tilde{f}_{w_1} + \tilde{f}_{w_2}$$

and

$$\tilde{g}_{\alpha u_1 + u_2}(v, w) = g(\alpha u_1 + u_2, v, w) = \alpha g(u_1, v, w) + g(u_2, v, w) = \alpha \tilde{g}_{u_1} + \tilde{g}_{u_2}.$$

By construction f and g for $\zeta_- : \text{Trilin}(U, V, W, -) \Rightarrow \text{Vect}_k(U \otimes (V \otimes W), -)$ and $\eta_- : \text{Trilin}(U, V, W, -) \Rightarrow \text{Vect}_k((U \otimes V) \otimes W, -)$ we have the following commutative diagrams.

$$\begin{array}{ccc} \text{Trilin}(U, V, W; X) & \xrightarrow{g^- \circ} & \text{Trilin}(U, V, W; Y) \\ \zeta_X \downarrow & & \downarrow \zeta_Y \\ \text{Vect}_k(U \otimes (V \otimes W), X) & \xrightarrow{g^- \circ} & \text{Vect}_k(U \otimes (V \otimes W), Y) \end{array}$$

$$\begin{array}{ccc} \text{Trilin}(U, V, W; X) & \xrightarrow{f^- \circ} & \text{Trilin}(U, V, W; Y) \\ \eta_X \downarrow & & \downarrow \eta_Y \\ \text{Vect}_k((U \otimes V) \otimes W, X) & \xrightarrow{f^- \circ} & \text{Vect}_k((U \otimes V) \otimes W, Y) \end{array}$$

Each leg in both these natural transformations are isomorphisms, so f and g represent the same functor. Thus by Proposition 2.3.1, we must have that

$$(U \otimes V) \otimes W \cong U \otimes (V \otimes W).$$

EXERCISE 2.3.iii. The set B^A of functions from a set A to a set B represents the contravariant functor $\text{Set}(- \times A, B) : \text{Set}^{\text{op}} \rightarrow \text{Set}$. The universal element for this representation is a function

$$\text{ev} : B^A \times A \rightarrow B$$

called the **evaluation map**. Define the evaluation map and describe its universal property, in analogy with the universal bilinear map \otimes of Example 2.3.7.

PROOF. In our case, we have that $\text{Set}(- \times A, B)$ is representable by the functions from A to B , denoted as B^A . We will start by unpacking the Yoneda lemma to get the following isomorphism:

$$\text{Hom}(\text{Set}(-, B^A), \text{Set}(- \times A, B)) \cong \text{Set}(B^A \times A, B).$$

Let $\alpha: \text{Set}(-, B^A) \Rightarrow \text{Set}(- \times A, B)$ be a natural isomorphism (that is, an element of the left side of the above isomorphism). The Yoneda bijection gives us that $\alpha \mapsto \alpha_{B^A}(1_{B^A})$. We want to show that $\text{ev} = \alpha_{B^A}(1_{B^A})$. The object $\alpha_{B^A}(1_{B^A})$ is a morphism $\text{Set}(B^A, B^A) \rightarrow \text{Set}(B^A \times A, B)$, given by $f \mapsto \tilde{f}$ such that for $a \in A$ and a function $g: A \rightarrow B$, $\tilde{f}(g, a) = \tilde{f}(g)(a)$. In our case, $f = 1_{B^A}$, so $\tilde{f}(g, a) = g(a) = \text{ev}(g, a)$. Then, $\alpha_{B^A}(1_{B^A}) = \text{ev}$.

In a more general sense, we have for any U and all functions $f: U \times A \rightarrow B$ there exists a unique $\tilde{f}: U \rightarrow B^A$, such that $f(u, a) = \tilde{f}(u)(a)$, this being the universal property of the evaluation map. \square

2.4 The category of elements

EXERCISE 2.4.i. Given $F: \mathbf{C} \rightarrow \mathbf{Set}$, show that $\int F$ is isomorphic to the comma category $\star \downarrow F$ of the singleton set $\star: \mathbb{1} \rightarrow \mathbf{Set}$ over the functor $F: \mathbf{C} \rightarrow \mathbf{Set}$.

PROOF. First recall from exercise 1.3.vi the definition of a comma category. In this case objects of $\star \downarrow F$ are triples of the form $(0 \in \mathbb{1}, c \in \mathbf{C}, h: \star \rightarrow Fc \in \mathbf{Set})$ and the morphisms are $(0, c, h) \rightarrow (0, c', h')$, a pair of morphisms $(1_\star: \star \rightarrow \star, k: c \rightarrow c')$ such that the following diagram commutes.

$$\begin{array}{ccc} \star & \xrightarrow{h} & z \\ 1_\star \downarrow & & \downarrow Fk \\ \star & \xrightarrow{h'} & z' \end{array}$$

This gives us that $h' = (Fk)h$. Define the functor $G: \star \downarrow F \rightarrow \int F$ as $(0, c, h) \mapsto (c, h)$ and $(1_\star: \star \rightarrow \star, k: c \rightarrow c') \mapsto k: c \rightarrow c'$ (note the k is in fact a morphism of $\int F$ as the above diagram commutes so $(Fk)h = h'$ as needed). Notice that G preserves composition in the obvious way and is invertible as $(1_\star, k) \mapsto k$ and $(0, c, h) \mapsto (c, h)$ have the inverses $k \mapsto (1_\star, k)$ and $(c, h) \mapsto (0, c, h)$ respectively, which also preserve composition in a similar fashion. This defines an isomorphism of categories, hence $\star \downarrow F$ is isomorphic to $\int F$. \square

EXERCISE 2.4.ii. Characterize the terminal objects of \mathbf{C}/c .

PROOF. We claim that one terminal object in \mathbf{C}/c is the identity morphism 1_c . To see this, we look at the diagram for a morphism in \mathbf{C}/c .

$$\begin{array}{ccc} x & \xrightarrow{h} & c \\ & \searrow g & \swarrow 1_c \\ & c & \end{array}$$

We must show that there is a unique h for any given object $g: x \rightarrow c$. But by the commutative diagram above, we see $g = 1_c \circ h = h$.

Thus, this h is uniquely defined, and there is a unique morphism that takes us from f to 1_c . This makes 1_c a terminal object.

By corollary 2.3.2, any two terminal objects in \mathbf{C}/c are uniquely isomorphic.

Suppose $f: x \rightarrow c$ is isomorphic to 1_c . We look at the composition diagram:

$$\begin{array}{ccccc} x & \xrightarrow{f} & c & \xrightarrow{j} & x \\ & \searrow f & \downarrow 1_c & \swarrow f & \\ & & c & & \end{array}$$

We can see that this diagram requires $fj = 1_c$ and the top row requires that $jf = 1_x$ for the composition to be the identity. Similarly, these criteria make the composition hold in the other order:

$$\begin{array}{ccccc} c & \xrightarrow{j} & x & \xrightarrow{f} & c \\ & \searrow & \downarrow f & \swarrow & \\ & 1_c & c & 1_c & \end{array}$$

Thus, for an isomorphism to exist between 1_c and arbitrary f , we must have that f is an isomorphism $x \rightarrow c$. Thus, the terminal objects are the isomorphisms $x \rightarrow c$ in \mathbf{C} . This can be seen in the diagram below.

$$\begin{array}{ccc} x & \xrightarrow{h} & c \\ & \searrow g & \swarrow f \\ & & c \end{array}$$

Note that if f is an isomorphism, we can let $h = jg$, where j is the unique inverse of f . Thus, $fh = fjg = g$, and the diagram commutes. \square

EXERCISE 2.4.iii. Use the principle of duality to convert the proof that a covariant functor is representable if and only if its category of elements has an initial object into a proof that a contravariant functor is representable if and only if its category of elements has a terminal object.

PROOF. Suppose that (c, x) is a terminal object in $\int F$, where $F: \mathbf{C}^{op} \rightarrow \mathbf{Set}$. We must show that the natural transformation $\Psi: \mathbf{C}(-, c) \Rightarrow F$ defined by the Yoneda Lemma is an isomorphism. First, consider an element $y \in Fd$. We know that we have a unique morphism $f: (d, y) \rightarrow (c, x)$ and so we have a unique morphism from $f: d \rightarrow c$ so that $Ff(x) = y$. Because of our definition of $\Psi(x)$, this means exactly that $\Psi(x)_d: \mathbf{C}(d, c) \rightarrow Fd$ is an isomorphism. This means that $\Psi(x)$ is a natural isomorphism and represents F .

In the other direction, we want to show that for a natural transformation $\alpha: \mathbf{C}(-, c) \Rightarrow F$, the pair $(c, \alpha_c(1_c))$ defined by the Yoneda bijection is a terminal object in the category of elements of F . Because α_d is a bijection, we have for every $y \in Fd$, a unique morphism $f: d \rightarrow c$ where $Ff: Fc \rightarrow Fd$ is such that $Ff(\alpha_c(1_c)) = y$. But this defines a unique homomorphism to $(c, \alpha_c(1_c))$ from every (d, y) in the category of elements, and so $(c, \alpha_c(1_c))$ is terminal. \square

EXERCISE 2.4.iv. Explain the sense in which the Sierpinski space is the universal topological space with an open subset.

PROOF. Let $O: \mathbf{Top}^{op} \rightarrow \mathbf{Set}$ be a functor that maps each topological spaces to its set of open sets and each continuous function $f: A \rightarrow B$ to function $g: OB \rightarrow OA$ where

$g(U) = f^{-1}(U)$. Let \mathcal{S} be the Sierpinski space and $\{x\}$ be the only non-trivial open set of \mathcal{S} . Since \mathcal{S} represents \mathcal{O} , then for each topological space T , each continuous function from T to \mathcal{S} corresponds bijectively with each open set of T . In fact the bijection would be defined by mapping each continuous function $f: T \rightarrow \mathcal{S}$ to $f^{-1}(\{x\}) = \mathcal{O}f(\{x\})$. In the category of elements $\int \mathcal{O}$, this means that for object (T, U) , there exists a unique morphism with domain (T, U) and codomain $(\mathcal{S}, \{x\})$ since there is only one continuous function $f: T \rightarrow \mathcal{S}$ such that $\mathcal{O}f(\{x\}) = U$. Thus the Sierpinski space is the universal topological space with an open subset in the sense that $(\mathcal{S}, \{x\})$ is terminal in $\int \mathcal{O}$.

EXERCISE 2.4.v. Define a contravariant functor $F: \mathbf{Set}^{\text{op}} \rightarrow \mathbf{Set}$ that carries a set to the set of preorders on it. What is its category of elements? Is F representable?

PROOF. We are given that F takes each set X to the set of preorders on it; that is, $FX = \{R \subseteq X \times X \mid R \text{ is a preorder}\}$. Let us define F_{Mor} such that for any morphism $f: X \rightarrow Y$ and any preorder $S \in FY$, $Ff(S) = \{(a, b) \subseteq X \times X \mid (f(a), f(b)) \in S\}$. Then for some $f: X \rightarrow Y$, $g: Y \rightarrow Z$, and preorder $T \in FZ$:

$$\begin{aligned} F(gf)(T) &= \{(a, b) \subseteq X \times X \mid (f(a), f(b)) \in \{(c, d) \subseteq Y \times Y \mid (f(c), f(d)) \in T\}\} \\ &= \{(a, b) \subseteq X \times X \mid (f(a), f(b)) \in Fg(T)\} \\ &= Ff(Fg(T)) \end{aligned}$$

So $F(gf) = FfFg$, meaning F fulfills the first functoriality axiom. Furthermore, the identity morphism takes every element to itself, which means $(f(a), f(b)) = (a, b)$; meaning F also fulfills the second functoriality axiom. So we have constructed a valid contravariant functor that acts on objects in the requested manner. \square

The objects of the category of elements of F (that is, $\int F$) are simply ordered pairs of the form (X, R) , where $R \in FX$; and the morphisms of $\int F$ are morphisms $(X, R) \rightarrow (Y, S) \in \int F$ is a morphism $f: X \rightarrow Y$ such that

$$Ff(S) = \{(a, b) \subseteq X \times X \mid (f(a), f(b)) \in S\} = R.$$

Suppose that F is represented by some set X . Then there is a natural isomorphism $\mathbf{C}(-, X) \cong F$, and therefore a bijection $\mathbf{Hom}(Y, X) \leftrightarrow FY$ for all sets Y . It is known that $\#\mathbf{Hom}(Y, X) = \#Y^{\#X}$, so this bijection means that $\#Y^{\#X} = \#FY$. Consider the case of a set A with 1 element: There is only one preorder¹ on A , so $1^{\#X} = 1$, which means X must have one element. But on the other hand, consider the case of a set B with two elements: There are four preorders² on B , so $2^{\#X} = 4$, which means X must have two elements. So we arrive at a contradiction, which means F cannot be represented by any set X — that is to say, F is not representable. \square

¹If we define the element of A as 0, the only possible preorder is $\{(0, 0)\}$, since preorders must be reflexive.

²If we define the elements of B as 0 and 1, these preorders are: $\{(0, 0), (1, 1)\}$, $\{(0, 0), (1, 1), (0, 1)\}$, $\{(0, 0), (1, 1), (1, 0)\}$ and $\{(0, 0), (1, 1), (0, 1), (1, 0)\}$.

EXERCISE 2.4.vi. For a locally small category \mathbf{C} , regard the two-sided represented functor $\text{Hom}(-, -): \mathbf{C}^{\text{op}} \times \mathbf{C} \rightarrow \text{Set}$ as a covariant functor of its domain $\mathbf{C}^{\text{op}} \times \mathbf{C}$. The category of elements of Hom is called the twisted arrow category. Justify this name by describing its objects and morphisms.

PROOF. We begin by describing the objects of the category of elements. As in the definition, the objects are pairs (c, x) . In this case, c is an object in $\mathbf{C}^{\text{op}} \times \mathbf{C}$, which in this context is a pair of elements in \mathbf{C} , (c_1, c_2) . We also know $x \in \text{Hom}(c_1, c_2)$, and thus x is a morphism between c_1 and c_2 . But we note that the objects can be described by just x , as c is merely the domain and range of x . Thus, the objects are morphisms, or "arrows."

Next, we consider the morphisms. A morphism h in $\text{Hom}(-, -)$ will take (f, g) , where $f: c_1 \rightarrow c_2$ and $g: c_3 \rightarrow c_4$ are morphisms in \mathbf{C} , to a function that takes morphism $x: c_2 \rightarrow c_3$ to gxf . This can be more clearly seen below:

$$\begin{array}{ccc} c_2 & \xrightarrow{x} & c_3 \\ f \uparrow & & \downarrow g \\ c_1 & & c_4 \end{array}$$

Then we note that the requirement that $Fh(x) = x'$ for morphisms in the category of elements. Thus we are given that $gxf = x'$, and get the following diagram.

$$\begin{array}{ccc} c_2 & \xrightarrow{x} & c_3 \\ f \uparrow & & \downarrow g \\ c_1 & \xrightarrow{x'} & c_4 \end{array}$$

Note how the arrows for f and g face opposite directions. This is the "twisted" part of the twisted arrow diagram. \square

EXERCISE 2.4.vii. Prove that the construction of the category of elements defines the action on objects of a functor

$$\int (-): \text{Set}^{\mathbf{C}} \rightarrow \text{CAT}/\mathbf{C}.$$

Conclude that if $F, G: \mathbf{C} \rightarrow \text{Set}$ are naturally isomorphic, then $\int F \cong \int G$ over \mathbf{C} .

PROOF. $\text{Set}^{\mathbf{C}}$ is the category where objects are functors from \mathbf{C} to Set . The category $\text{CAT}/\mathbf{C} = \int \text{CAT}(-, \mathbf{C})$ has as objects functors with codomain \mathbf{C} . So, the functor $\int (-)$ takes a functor from $\mathbf{C} \rightarrow \text{Set}$ to a functor with codomain \mathbf{C} .

The construction of the category of elements of a functor $F: \mathbf{C} \rightarrow \text{Set}$ creates pairs (c, x) where $c \in \mathbf{C}$ and $x \in Fc$. Letting $\int (-)$ take objects to objects by $Fc \mapsto (c, Fc)$, we can see that the pair can be viewed as part of the data of a functor from $\text{CAT} \rightarrow \mathbf{C}$. So, $\int (-)$ acts on objects by taking the functor F to its data viewed as pairs.

If $F, G: \mathbf{C} \rightarrow \mathbf{Set}$ are naturally isomorphic, then there is an isomorphism between Fc and Gc for all $c \in \mathbf{C}$, and in their respective categories of elements, we would have that $(c, Fc) \cong (c, Gc)$ by the aforementioned isomorphism on the second component. Since these pairs are the contents of $\int F$ and $\int G$ over \mathbf{C} , we have that $\int F \cong \int G$ over \mathbf{C} .

EXERCISE 2.4.viii. Prove that for any $F: \mathbf{C} \rightarrow \mathbf{Set}$, the canonical forgetful functor $\Pi: \int F \rightarrow \mathbf{C}$ has the following property: for any morphism $f: c \rightarrow d$ in the “base category” \mathbf{C} and any object (c, x) in the fiber over c , there is a unique lift of the morphism f to a morphism in $\int F$ with domain (c, x) that projects along Π to f . A functor with this property is called a **discrete left fibration**.

PROOF. Recall that the objects of $\int F$ are pairs (c, x) such that $x \in Fc$ and morphisms are pointed maps compatible with the pairs. The canonical forgetful functor simply takes (c, x) to c and a morphism to itself. If we are given a morphism $f: c \rightarrow d$ and an object (c, x) , then by the nature of functions, there is a unique $y \in Fd$ such that $Ff(x) = y$. This y determines a unique object (d, y) in $\int F$ along with a morphism $f: (c, x) \rightarrow (d, y)$. It is clear that this is the only morphism satisfying $Ff(x) = y$. \square

EXERCISE 2.4.ix. Formulate the dual definition of a discrete right fibration satisfied by the canonical functor $\Pi: \int F \rightarrow \mathbf{C}$ associated to a covariant functor $F: \mathbf{C}^{op} \rightarrow \mathbf{Set}$.

PROOF. For the **discrete right fibration**, take any $F: \mathbf{C}^{op} \rightarrow \mathbf{Set}$. Now providing the forgetful functor $\Pi: \int F \rightarrow \mathbf{C}$ with the conditions that for any morphism $f: c \rightarrow d$ in \mathbf{C} , and any object (c, x) in the fiber over d , there exists a unique lift of the morphism f to a morphism in $\int F$ with domain (d, x') . Namely, $\Pi: (c, x) \rightarrow (d, Ff(x')) = f: c \rightarrow d$. This lifted morphism in $\int F$ will project along Π to f , such that $Ff(x') = x$.

EXERCISE 2.4.x. Answer the question posed at the end of this section: fixing two objects A, B in a locally small category \mathbf{C} , we define a functor

$$\mathbf{C}(A, -) \times \mathbf{C}(B, -) : \mathbf{C} \rightarrow \mathbf{Set}$$

that carries an object X to the set $\mathbf{C}(A, X) \times \mathbf{C}(B, X)$ whose elements are pairs of maps $a: A \rightarrow X$ and $b: B \rightarrow X$ in \mathbf{C} . What would it mean for this functor to be representable?

The answer is actually in Remark 3.1.27 in the next chapter. Namely, this functor is representable if and only if A and B have a coproduct $D = A \amalg B$ in \mathbf{C} .

In more detail, say that we have an object D of \mathbf{C} together with morphisms $\iota_A : A \rightarrow D$ and $\iota_B : B \rightarrow D$ that for every object X of \mathbf{C} induce a bijection

$$I_X : \mathbf{C}(D, X) \rightarrow \mathbf{C}(A, X) \times \mathbf{C}(B, X)$$

by $I_X(f) = (f\iota_A, f\iota_B)$. Then for any $g : X \rightarrow Y$ we have a commutative diagram

$$\begin{array}{ccc} \mathbf{C}(D, X) & \xrightarrow{g^*} & \mathbf{C}(D, Y) \\ I_X \downarrow & & \downarrow I_Y \\ \mathbf{C}(A, X) \times \mathbf{C}(B, X) & \xrightarrow{(g^*, g^*)} & \mathbf{C}(A, Y) \times \mathbf{C}(B, Y) \end{array}$$

so that $I : \mathbf{C}(D, -) \Rightarrow \mathbf{C}(A, -) \times \mathbf{C}(B, -)$ is a natural isomorphism of functors, making D a representing object for $\mathbf{C}(A, -) \times \mathbf{C}(B, -)$.

Conversely, say that for some object D of \mathbf{C} we have a natural isomorphism $I : \mathbf{C}(D, -) \Rightarrow \mathbf{C}(A, -) \times \mathbf{C}(B, -)$. Then define $\iota_A : A \rightarrow D$ and $\iota_B : B \rightarrow D$ to be the two components of $I_D(1_D) \in \mathbf{C}(A, D) \times \mathbf{C}(B, D)$. That is, $I_D(1_D) = (\iota_A, \iota_B)$.

Since I is a natural isomorphism from $\mathbf{C}(D, -)$ to $\mathbf{C}(A, -) \times \mathbf{C}(B, -)$ we have for every object X that $I_X : \mathbf{C}(D, X) \rightarrow \mathbf{C}(A, X) \times \mathbf{C}(B, X)$ is a bijection. We wish to show that I_X is given by the formula above. To see this, note that for any $f \in \mathbf{C}(D, X)$ we have a commutative diagram

$$\begin{array}{ccc} \mathbf{C}(D, D) & \xrightarrow{f^*} & \mathbf{C}(D, X) \\ I_D \downarrow & & \downarrow I_X \\ \mathbf{C}(A, D) \times \mathbf{C}(B, D) & \xrightarrow{(f^*, f^*)} & \mathbf{C}(A, X) \times \mathbf{C}(B, X) \end{array} .$$

Using the commutativity of this diagram, we have that

$$I_X(f) = I_X f^*(1_D) = (f^*, f^*) I_D(1_D) = (f^*, f^*)(\iota_A, \iota_B) = (f\iota_A, f\iota_B)$$

as claimed.

Chapter 3

Limits and Colimits

3.1 Limits and colimits as universal cones

EXERCISE 3.1.i. For a fixed diagram $F \in \mathbf{C}^{\mathbf{J}}$, describe the actions of the cone functors $\text{Cone}(-, F): \mathbf{C}^{op} \rightarrow \text{Set}$ and $\text{Cone}(F, -): \mathbf{C} \rightarrow \text{Set}$ on morphisms in \mathbf{C} .

PROOF. In the contravariant case, the domain of the cone functor $\text{Cone}(-, F)$ on morphisms $f: c \rightarrow c'$ in \mathbf{C}^{op} , is a morphism that takes the constant functor c to c' , and thus is a natural transformation $f: c \Rightarrow c'$. The contravariant cone functor then sends f to the mapping $f: \text{Cone}(c', F) \rightarrow \text{Cone}(c, F)$. From this mapping, for a cone in the domain of f^* , which is a natural transformation $\lambda: c' \Rightarrow F$, the cone functor results in the precomposition of f with λ , namely, λf .

Likewise for the covariant case, the cone functor $\text{Cone}(F, -): \mathbf{C} \rightarrow \text{Set}$ sends morphisms from c to c' to postcomposition of the natural transformations comprising the sets cones under c with f , namely, $f\lambda$.

EXERCISE 3.1.ii. For a fixed diagram $F \in \mathbf{C}^{\mathbf{J}}$, show that the cone functor $\text{Cone}(-, F)$ is naturally isomorphic to $\text{Hom}(\Delta(-), F)$, the restriction of the hom-functor for the category $\mathbf{C}^{\mathbf{J}}$ along the constant functor embedding defined in 3.1.1.

PROOF. First, we note what we must show that we can define for each $c \in \mathbf{C}$, a function $\eta_c: \text{Cone}(c, F) \rightarrow \text{Hom}(\Delta(c), F)$ that causes the following diagram to commute for

$f: c \rightarrow c'$.

$$\begin{array}{ccc}
 \text{Cone}(c', F) & \xrightarrow{\text{Cone}(-, F)(f)} & \text{Cone}(c, F) \\
 \eta_{c'} \downarrow & & \downarrow \eta_c \\
 \text{Hom}(\Delta(c'), F) & \xrightarrow{\text{Hom}(\Delta(-), F)(f)} & \text{Hom}(\Delta(c), F)
 \end{array} \tag{3.1}$$

Now, we note definition 3.1.2, which defines a cone over F with apex c as a natural transformation $\lambda: \Delta(c) \rightarrow F$. We also see that $\epsilon \in \text{Hom}(\Delta(c), F)$ is defined by the following commutative diagram for a morphism $f: d \rightarrow e$.

$$\begin{array}{ccc}
 c & \xrightarrow{1_c} & c \\
 \epsilon_d \downarrow & & \downarrow \epsilon_e \\
 Fd & \xrightarrow{Ff} & Fe
 \end{array} \tag{3.2}$$

We can condense this diagram into the triangular diagram

$$\begin{array}{ccc}
 & c & \\
 \epsilon_d \swarrow & & \searrow \epsilon_e \\
 Fd & \xrightarrow{Ff} & Fe
 \end{array} \tag{3.3}$$

Since we have a diagram like this for every $f \in \text{mor } \mathbf{C}$, we see that ϵ defines a cone in $\text{Cone}(c, F)$. So we see that elements $\text{Cone}(c, F)$ and $\text{Hom}(\Delta(c), F)$ describe the same class of natural transformations. So the image of c under the functors $\text{Cone}(-, F)$ and $\text{Hom}(\Delta(-), F)$ is identical. So these functors behave identically on objects.

We know by exercise 3.1.i that $\text{Cone}(-, F)(f): \text{Cone}(c', F) \rightarrow \text{Cone}(c, F)$ takes a $\lambda_i: c' \rightarrow Fi$ to $\lambda_i f: c \rightarrow F$. We also see that by definition 3.1.1, that for an $\epsilon \in \text{Hom}(\Delta(c'), F)$ and $f: c \rightarrow c'$, that $\text{Hom}(\Delta(-), F)(f) = \epsilon * \Delta(f)$, where $\Delta(f)$ is the constant natural transformation defined by f between the functors $\Delta(c')$ and $\Delta(c)$. Since we are vertically composing these natural transformations, we see that $(\epsilon * f)_i = \epsilon_i f_i = \epsilon_i f$. So these functors also behave identically on morphisms and so they are identical and have a trivial natural isomorphisms between them. \square

EXERCISE 3.1.iii. Prove that the category of cones over $F \in \mathbf{C}^{\mathbf{J}}$ (for which I will use the notation Cone_F) is isomorphic to the comma category $\Delta \downarrow F$ formed from the constant functor $\Delta: \mathbf{C} \rightarrow \mathbf{C}^{\mathbf{J}}$ and the functor $F: \mathbf{1} \rightarrow \mathbf{C}^{\mathbf{J}}$. Argue by duality that the category of cones under F is the comma category $F \downarrow \Delta$.

To clarify, the functor $F: \mathbf{1} \rightarrow \mathbf{C}^{\mathbf{J}}$ is the 'constant functor' taking every element of $\mathbf{1}$ (that is to say, the *only* element of $\mathbf{1}$) to the diagram $F \in \mathbf{C}^{\mathbf{J}}$.

Proof.

PROOF. Every element of $\Delta \downarrow F$ must be of the form $(c, 0, m)$, where $c \in \mathbf{C}$, $0 \in \mathbb{1}$, and $m: \Delta c \rightarrow 0 \in \mathbf{C}^{\mathbf{J}}$. Note that for any such tuple, $\Delta c = c \in \mathbf{C}^{\mathbf{J}}$ and $0 = F \in \mathbf{C}^{\mathbf{J}}$. So m must be a natural transformation within $\mathbf{C}^{\mathbf{J}}$ from some constant functor to the functor whose codomain is the diagram F . So a tuple $(c, 0, m) \in \Delta \downarrow F$ corresponds to the diagram F (determined by whatever diagram we chose the functor F to 'point to,') an object c in \mathbf{C} , and a natural transformation $m: c \rightarrow F \in \mathbf{C}$. Since m is a natural transformation, all of its components must commute. But since c was defined as the codomain of a constant functor, its only endomorphism is the identity. So m can be described by the following diagram: □

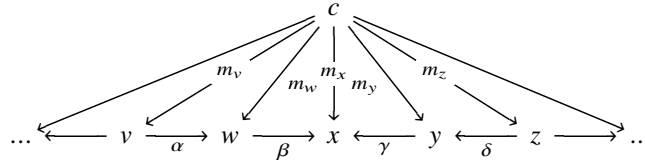

where v, w, x, y, z , etc. and $\alpha, \beta, \gamma, \delta$, etc. are objects and morphisms in F , respectively. But if this diagram commutes, it is simply the diagram of a cone over F with apex c , whose legs are the components of m ! So each distinct tuple in $\Delta \downarrow F$ describes a unique cone over F , with the first component of the tuple determining the apex of that cone and the second component determining its legs. So we can define a bijection ϕ between $\Delta \downarrow F$ and Cone_F that associates each tuple $(c, 0, m) \in \Delta \downarrow F$ with the unique cone $(c, m) \in \text{Cone}_F$ (where c is the apex of the cone and m is the natural transformation $c \Rightarrow m$ whose components are the legs of the cone.)

Furthermore, note that the morphisms in $\Delta \downarrow F$ must be of the form $(h, k): (c, 0, m) \rightarrow (c', 0, m')$ such that the following commutes:

$$\begin{array}{ccc} \Delta c & \xrightarrow{m} & F0 \\ \downarrow \Delta h & & Fk \downarrow \\ \Delta c' & \xrightarrow{m'} & F0 \end{array}$$

But for any $(h, k) \in \Delta \downarrow F$, $k: 0 \rightarrow 0$ can only be 1_0 , which means Fk can only be 1_F , since functors preserve identities. Furthermore, for some $h: c \rightarrow c'$, every leg of $\Delta h: c \rightarrow c'$ is the morphism h . So the above diagram can be redrawn as

$$\begin{array}{ccc} c & \xrightarrow{m} & 0 \\ \downarrow h & & 1_0 \downarrow \\ c' & \xrightarrow{m'} & 0 \end{array}$$

and further simplified to

$$\begin{array}{ccc} c & \xrightarrow{h} & c' \\ \downarrow m & \swarrow m' & \\ & & F \end{array}$$

Notice that since this diagram commutes, the morphism $m: c \rightarrow x$ is equal to $m'h$. So any morphism $(h, k): (c, 0, m) \rightarrow (c', 0, m')$ is uniquely defined by its component $h: c \rightarrow c'$. So we can create a bijection φ_1 associating each (h, k) with the unique

$h: c \rightarrow c' \in \mathbf{C}^{\mathbf{J}}$ that defines it. But recall that any natural transformation between cones is *also* uniquely defined by the component that acts on the apexes of those cones. So we can create another bijection φ_2 that takes each morphism $h: (c, m) \rightarrow (c', m') \in \mathbf{Cone}_F$ to the unique $h: c \rightarrow c' \in \mathbf{C}^{\mathbf{J}}$ that defines it. Finally, we can create a bijection $\varphi = \varphi_1\varphi_2$ that takes each $(h, k): (c, 0, m) \rightarrow (c', 0, m) \in \Delta \downarrow F$ to the unique $h: (c, m) \rightarrow (c', m') \in \mathbf{Cone}_F$ that is defined by the same $h: c \rightarrow c' \in \mathbf{C}^{\mathbf{J}}$.

So now we have a bijection ϕ between the objects of $\Delta \downarrow F$ and the objects of \mathbf{Cone}_F and a bijection φ between the morphisms of $\Delta \downarrow F$ and the morphisms of \mathbf{Cone}_F that preserves those morphisms' domains and codomains. So we can finally say that there is an isomorphism Ξ between $\Delta \downarrow F$ and \mathbf{Cone}_F , where $\Xi_{Obj} = \phi$ and $\Xi_{Mor} = \varphi$. So $\Delta \downarrow F$ is isomorphic to \mathbf{Cone}_F . \square

Furthermore, note that for every morphism going from an object $x \in F$ to the nadir c of a cone under F in $\mathbf{C}^{\mathbf{J}}$, there is a corresponding morphism in $\mathbf{C}^{op, J^{op}}$ going from c to x . So every cone under $F \in \mathbf{C}^{\mathbf{J}}$ is also a cone over $F \in \mathbf{C}^{op, J^{op}}$. We might be tempted to stop here, but recall that when creating the comma category $\Delta \downarrow F$, we defined the third component of each tuple to be a morphism in \mathbf{C} , not \mathbf{C}^{op} .

So in order for our proof to still hold in the dual case, we must replace the third component in each tuple with its corresponding morphism in \mathbf{C}^{op} . This morphism certainly exists, but in a comma category the third component of each tuple must be a morphism from the image of the first component to the image of the second. So if we "turn around" that third component of every tuple in the category, we must also switch the positions of the first and second components of every tuple in the category; which gives us the comma category $F \downarrow \Delta$. Now the proof by duality in the previous paragraph is valid, which means the category of cones under F is in fact isomorphic to $F \downarrow \Delta$. \square

EXERCISE 3.1.iv. Give a second proof of Proposition 3.1.7 by using the universal properties of each of a pair of limit cones $\lambda: l \Rightarrow F$ and $\lambda': l' \Rightarrow F$ to directly construct the unique isomorphism $l \cong l'$ between their apexes.

PROOF. Since λ and λ' are limit cones, for any cones $\Lambda: c \Rightarrow F$ and $\Lambda': c' \Rightarrow F$ there are unique morphisms $f: c \rightarrow l$ and $f': c' \rightarrow l'$ such that $\Lambda = \lambda f$ and $\Lambda' = \lambda' f'$.

In the case in which $\Lambda = \lambda$ and $\Lambda' = \lambda'$, the unique f and f' satisfying $\lambda = \lambda f$ and $\lambda' = \lambda' f'$ are $f = 1_l$ and $f' = 1_{l'}$.

In the case in which $\Lambda = \lambda'$ and $\Lambda' = \lambda$ we obtain unique morphisms $g: l' \rightarrow l$ and $g': l \rightarrow l'$ such that $\lambda' = \lambda g$ and $\lambda = \lambda' g'$.

Thus, $\lambda = \lambda' g' = \lambda g g'$. But, we have already seen that the unique morphism f such that $\lambda = \lambda f$ is 1_l . So, $g g' = 1_l$. Similarly, $\lambda' = \lambda g = \lambda' g' g$ and a similar uniqueness argument made above shows us that $g' g = 1_{l'}$.

So, g and g' are inverse isomorphisms between l and l' as required.

EXERCISE 3.1.v. Consider a diagram $F: \mathbf{J} \rightarrow \mathbf{P}$ valued in a poset (\mathbf{P}, \leq) . Use order-theoretic language to characterize the limit and the colimit.

PROOF. Consider a cone over F where in \mathbf{P} , $x \leq y \leq z$:

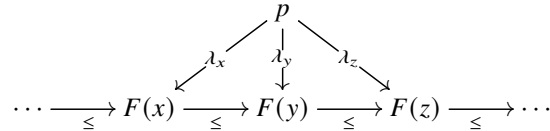

Where $\lambda = (\lambda_n: p \rightarrow Fn)_{n \in \mathbf{P}}$, the family of order preserving morphisms from p to F . We know that $\lim F$ is a terminal object in the category of cones over F . If p is a limit of F (as in the diagram above), then any other cone q with morphisms $\gamma_n: q \rightarrow Fn$ (for all Fn) must have that γ_n factors through λ_n . So there must exist some morphism from $q \rightarrow p$, which would imply that $q \leq p$ in (\mathbf{P}, \leq) . Moreover, this morphism is unique, since in a poset category there can be at most one morphism between any two objects. Given that $q \leq p$ for all q , and that p has morphisms to all Fn , we have that p is an infimum of $\{Fn \mid n \in \text{ob } \mathbf{J}\}$, if it exists. Dually, the colimit would be a supremum, if it exists. In both cases, limits and colimits are unique up to isomorphism (Proposition 3.1.7), and similarly, the infimum and supremum are unique. \square

EXERCISE 3.1.vi. Prove that if

$$E \xrightarrow{h} A \begin{array}{c} \xrightarrow{f} \\ \xrightarrow{g} \end{array} B$$

is an equalizer diagram, then h is a monomorphism.

PROOF. By the universal property for an $a: C \rightarrow A$, there exists a unique factorization $k: C \rightarrow E$ of a through h . This implies that if $fa = ga$ then the following diagram commutes.

$$\begin{array}{ccccc}
 C & & & & \\
 \downarrow & \searrow a & & & \\
 \exists! k \downarrow & & & & \\
 E & \xrightarrow{h} & A & \begin{array}{c} \xrightarrow{f} \\ \xrightarrow{g} \end{array} & B
 \end{array}$$

To show h is a monomorphism define another morphism $b: C \rightarrow E$ such we get a commutative diagram.

$$\begin{array}{ccccc}
 C & & & & \\
 \downarrow & \searrow a & & & \\
 b \downarrow & \exists! k \downarrow & & & \\
 E & \xrightarrow{h} & A & \begin{array}{c} \xrightarrow{f} \\ \xrightarrow{g} \end{array} & B
 \end{array}$$

Because the above diagram commutes we get see that $ghb = fhb$. Since $hb: C \rightarrow A$ and $ghb = fhb$, the universal property tells us that we can factor hb through h by k . So $hb = hk$, but since k is unique we must have $b = k$. Thus h is left cancellable and therefore a monomorphism.

EXERCISE 3.1.vii. Prove that if

$$\begin{array}{ccc} P & \xrightarrow{k} & C \\ \downarrow h & \lrcorner & \downarrow g \\ B & \xrightarrow{f} & A \end{array}$$

is a pullback square and f is a monomorphism, then k is a monomorphism.

(Recall: the notation \succrightarrow means that f is mono.)

PROOF. Consider morphisms $l, e: D \rightarrow P$ where $ke = kl$ and P is the pullback cone. We have that $gkl = gke$, which due to the commutativity of the diagram is the same as $fhl = fhe$, but since f is mono, $hl = he$. Letting $c = kl = ke$ and $b = hl = he$, we have the following diagram.

$$\begin{array}{ccccc} D & & & & \\ & \searrow c & & & \\ & & P & \xrightarrow{k} & C \\ & \searrow d & \downarrow h & \lrcorner & \downarrow g \\ & & B & \xrightarrow{f} & A \\ & \searrow b & & & \end{array}$$

Then we have that $gc = fb$ and there must be a unique morphism d where $c = kd$ and $b = hd$. Since d is unique, we must have that $l = e$ and thus k is a monomorphism. \square

EXERCISE 3.1.viii. Consider a commutative rectangle

$$\begin{array}{ccccc} \bullet & \longrightarrow & \bullet & \longrightarrow & \bullet \\ \downarrow & & \downarrow & \lrcorner & \downarrow \\ \bullet & \longrightarrow & \bullet & \longrightarrow & \bullet \end{array}$$

whose right-hand square is a pullback. Show that the left-hand square is a pullback if and only if the composite rectangle is a pullback.

PROOF. For ease of reference we will give the objects in the above diagram names as follows.

$$\begin{array}{ccccc}
 a & \longrightarrow & b & \longrightarrow & w \\
 \downarrow & & \downarrow & \lrcorner & \downarrow \\
 x & \longrightarrow & y & \longrightarrow & z
 \end{array}$$

Recall that a pullback is the limit of a functor from $\bullet \rightarrow \bullet \leftarrow \bullet$, so we are dealing with three functors from this category with the following images:

$$x \rightarrow z \leftarrow y, \quad y \rightarrow z \leftarrow w, \quad \text{and} \quad x \rightarrow y \leftarrow b.$$

Note that the map from x to z factors through y .

Further note that because b is a pullback and a is the apex of cone with $y \rightarrow z \leftarrow w$ as a base (with the composite maps $a \rightarrow x \rightarrow y$ and $a \rightarrow b \rightarrow w$ as legs), the map $a \rightarrow b$ is unique.

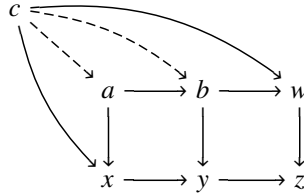

Suppose first that the left-hand square is a pullback along with the right-hand square, and there is an apex c to the cone with $x \rightarrow z \leftarrow w$ as a base. By taking $c \rightarrow x \rightarrow y$ as a leg, c is a cone over $y \rightarrow z \leftarrow w$ and thus there is a unique map $c \rightarrow b$ making c also the apex of a cone over $x \rightarrow y \leftarrow b$. Thus there is a unique map $c \rightarrow a$ making the whole diagram commute. Thus a is the limit of $x \rightarrow z \leftarrow w$.

Conversely suppose that the whole diagram is a pullback and that c is a cone over $x \rightarrow y \leftarrow b$. Then c is also a cone over $x \rightarrow z \leftarrow w$ with $a \rightarrow b \rightarrow w$ as a leg. Thus we again have a unique map $c \rightarrow a$ that makes the diagram commute, and a is also the limit of $x \rightarrow y \leftarrow b$. \square

EXERCISE 3.1.ix. Show that if J has an initial object, then the limit of any functor indexed by J is the value of that functor at an initial object. Apply the dual of this result to describe the colimit of a diagram indexed by a successor ordinal.

PROOF. We begin by showing that an initial object of J gives a limit for any functor $F: J \rightarrow C$ where C is some category. Letting $*$ be an initial object of J , for any object j in J there is precisely one map $\lambda_j: * \rightarrow j$. For $*$ to form a cone over F we need a family of morphisms from $F*$ to Fj for each object j in sJ . An obvious (but not necessarily required) choice is to take $F\lambda_j$. Now we need only check that for every morphism $f: j \rightarrow k$ in J

the identity $FfF\lambda_j = F\lambda_k$. Because $f\lambda_j = \lambda_k$ this is precisely the condition that F is functorial.¹

Now suppose that c is the apex of a cone over F , so there is a distinguished map $\rho_j: c \rightarrow Fj$ for each j in J satisfying the naturality condition of a cone. For F^* to be the limit of F , there must be a unique map $\psi: c \rightarrow F^*$ such that $\rho_j = F\lambda_j\psi$. In particular we need that $\rho_* = F\lambda_*\psi$, however, λ_* is the identity on $*$, so we have $\rho_* = \psi$. Thus the leg of the cone from c to F^* gives us the unique map we require.

$$\begin{array}{ccc} c & & \\ \rho_* \downarrow & \searrow \rho_j & \\ F^* & \xrightarrow{F\lambda_j} & Fj \end{array}$$

Note that both limits and initial objects are unique up to a canonical isomorphism, which conforms with our result. If J had multiple initial objects, by the argument above all of these would give limits of a cone based on J , and the unique isomorphism between two initial objects would transfer to \mathbf{C} to give us the canonical isomorphism between limits.

Now consider the case of a successor ordinal category \mathfrak{n} and a functor $F: \mathfrak{n} \rightarrow \mathbf{C}$. Note first that a successor ordinal n by definition is the successor of some other ordinal denoted $n - 1$.² Considered as a poset, any ordinal is a well-ordered chain:³ the set of all strictly smaller ordinals ordered under inclusion. If \mathfrak{n} is a successor ordinal, then this poset has maximum element $n - 1$, i.e. $m \subset n - 1$ for any $m \in \mathfrak{n}$.

Considered as a category, a poset has as maps the elements of a relation, in this case \subset , and as objects the elements of the poset. Thus the condition that $n - 1$ is a maximum element is precisely saying that $n - 1$ is a terminal object in \mathfrak{n} .

The dual of the above result gives precisely that the colimit of a functor indexed by a diagram with a terminal object is the value of the functor at the terminal object. Instead of considering an apex c with maps leading into the image of our diagram we instead consider a nadir with maps leading from our diagram to c . It is clear that a terminal object will satisfy the argument above with the arrows reversed. This means that the functor $F: \mathfrak{n} \rightarrow \mathbf{C}$ has as a colimit $F(n - 1)$. \square

EXERCISE 3.1.x. If (a, b) are positive integers satisfying the universal property of (3.1.20) show that the pair $(-a, -b)$ also satisfies the same universal property. Explain why this observation does not imply that the pullback is ill-defined.

¹Note that this is weaker than saying that any triangle in the image of F must commute.

$$\begin{array}{ccc} & F_* & \\ & \swarrow \quad \searrow & \\ Fj & \longrightarrow & Fk \end{array}$$

It is

entirely possible to create new composable pairs if F is not injective on objects. Even if $Fj = Fj'$, $F\lambda_j$ and $F\lambda_{j'}$ may be distinct. Given a map $f: j \rightarrow k$, it need not be true that $FfF\lambda_{j'} = F\lambda_k$, but this is immaterial to the naturality of the $F\lambda_j$.

²In contrast a limit ordinal like ω or 2ω is not the successor of any other ordinal and is instead the least upper bound of an otherwise unbounded collection.

³This chain need not be finite. The ordinal $\omega + 1 = \omega \cup \{ \omega \}$ is a successor ordinal with maximum element ω .

PROOF. **Mark how do I get the angle on this diagram** For reference (3.1.20) is the following commutative diagram.

$$\begin{array}{ccc} \mathbb{Z} & \xrightarrow{-b} & \mathbb{Z} \\ \downarrow a & \lrcorner & \downarrow n \\ \mathbb{Z} & \xrightarrow{m} & \mathbb{Z} \end{array}$$

We know from undergraduate algebra the least common multiple of two integers is only unique up to multiplication by a unit. Therefore, $(-a, -b)$ should satisfy the above diagram as well. The pullback is unique ⁴ up to isomorphism. Since -1 is an automorphism on \mathbb{Z} that takes (a, b) to $(-a, -b)$, so in either case the diagrams are essentially the same thing as far as we are concerned. \square

LEMMA 3.1.1 (3.2.vi). *Prove that the limit of any small functor $F : C \rightarrow \mathbf{Set}$ is isomorphic to the set of functors $C \rightarrow \int F$ that defines a section to the canonical projection $\prod : \int F \rightarrow C$ from the category of elements of F . Using this description of the limit, define the limit cone.*

PROOF. Since the category \mathbf{Set} is complete, every diagram F has limits valued in C . Thus we want to show that this set of limits is isomorphic to the set of functors $C \rightarrow \int F$.

Let $\{\phi\}_{i \in ob C}$ be the set of functors $C \rightarrow \int F$, which defines a section to $\prod : \int F \rightarrow C$, such that, for $C \rightarrow \phi_i \int F \rightarrow \prod C$, $\prod \phi_i = 1_C$ for all $i \in ob C$, where \prod is the forgetful functor. So $\prod \phi_i$ takes objects in C to objects in C , forgetting covariance built into the category of elements along the way.

Define a function $f : x \rightarrow y$, for $x \in \{\phi\}_{i \in ob C}$ and $y \in \lim F$. \square

EXERCISE 3.1.xi. Suppose $E : I \rightarrow J$ defines an equivalence between small categories and consider a diagram $F : J \rightarrow C$. Show that the category of J -shaped cones equivalent to the category of I -shaped cones over FE , and use this equivalence to describe the relationship between limits of F and limits of FE .

PROOF. We will denote the category of cones over some diagram $G : J \rightarrow C$ as \mathbf{Cone}_G . Recall the following facts for \mathbf{Cone}_G :

1. Objects of \mathbf{Cone}_G are natural transformations $\alpha : c_J \Rightarrow G$ where c_J is the constant functor mapping every object in J to c and every morphism to 1_c .
2. A morphism $f : \alpha \rightarrow \beta$ between cones $\alpha : c_J \Rightarrow G$ and $\beta : d_J \Rightarrow G$ is the natural transformation $f_J : d_J \Rightarrow c_J$ where every component of f_J is f and $\alpha \cdot f_J = \beta$.
3. The identity morphism of α is simply 1_{c_J} where c_J is the domain of α .
4. Composition of morphisms is composition of natural transformations.

Now we will define the functor $RW_E : \mathbf{Cone}_F \rightarrow \mathbf{Cone}_{FE}$ as follows:

1. RW_E maps cone α to αE where for $i \in ob I$ the corresponding component is $\alpha_{Ei} : c \rightarrow FEi$, in other words, αE is a restriction of α to the image of the functor E .
2. RW_E maps morphism f_J to f_I .
3. RW_E performs a right whiskering of E onto natural transformations.

⁴Like everything else in category theory probably

RW_E is clearly a functor since the composition $g_J \cdot f_J$ gets mapped to $g_I \cdot f_I$ and 1_{c_J} gets mapped onto 1_{c_I} . Now we will show that RW_E is an equivalence. First we will show essential surjectivity. Suppose γ is an object in \mathbf{Cone}_{FE} , we will construct a natural transformation γ^F such that $\gamma_j^F = F\phi_j \cdot \gamma_i$ where i is an object in \mathbf{l} such that $Ei \cong j$. and $\phi_j: Ei \rightarrow j$ is an isomorphism. When $Ei = j$, we will let $\phi_j = 1_j$. Our construction is well-defined since E is essentially surjective. To show that γ^F is a natural transformation, take a morphism $a: j \rightarrow j'$ in \mathbf{J} . We can show that $a = \phi_{j'} b \phi_j^{-1}$ for a unique b in $\mathbf{J}(Ei, Ei')$, where $Ei \cong j$ and $Ei' \cong j'$. We can form a bijection from $\mathbf{J}(Ei, Ei')$ to $\mathbf{J}(j, j')$ by pre-composing ϕ_j^{-1} and post-composing $\phi_{j'}$. Furthermore since E is full and faithful, there exist a unique $c \in \mathbf{l}(i, i')$ such that $b = Ec$. We can claim that $a = \phi_{j'} Ec \phi_j^{-1}$ for a unique $c \in \mathbf{l}(i, i')$. Now we must show that $Fa \cdot \gamma_j^F = \gamma_{j'}^F$, but this is equivalent to $F Ec \cdot \gamma_i = \gamma_{i'}$ which follows from naturality of γ . Thus γ^F is natural and is a cone over F . Applying RW_E to γ^F gives us γ since each ϕ_{Ei} for $i \in \mathbf{ob} \mathbf{l}$ is the identity. Thus RW_E is essentially surjective.

To show full and faithful take cones α and β and suppose f_J and g_J are morphisms from α to β such that $RW_E f_J = RW_E g_J$. Then $f_I = g_I$ which means that $f = g$. Thus $f_J = g_J$. Now take a morphism h_I from αE to βE , we must show that h_J is a morphism from α to β . Since we already have that $\alpha_{Ei} \cdot h = \beta_{Ei}$ for all $i \in \mathbf{ob} \mathbf{l}$, by naturality, for each $k: Ei \rightarrow j$ in \mathbf{J} , we have that $Fk \cdot \alpha_{Ei} = \alpha_j$ and $Fk \cdot \beta_{Ei} = \beta_j$. Since, E is essentially surjective, for any $j \in \mathbf{ob} \mathbf{J}$, we have an isomorphism $\phi_j: Ei \rightarrow j$ for some i allowing the equality $F\phi_j \cdot \alpha_{Ei} \cdot h = F\phi_j \cdot \beta_{Ei}$ which gives us $\alpha_j \cdot h = \beta_j$ for all j . Thus h_J is a morphism from α to β .

Thus RW_E is full, faithful, and essentially surjective. Therefore, \mathbf{Cone}_F is equivalent to \mathbf{Cone}_{FE} .

Suppose F had a limit cone ω_F , then by the universal property of limits, ω_F is terminal in \mathbf{Cone}_{FE} . Since RW_E is full, faithful, and essentially surjective then for all cones β over FE , there exist a cone α of F such that $\mathbf{Cone}_F(\alpha, \omega_F) \cong \mathbf{Cone}_{FE}(\alpha E, \omega_{FE}) \cong \mathbf{Cone}_{FE}(\beta, \omega_{FE})$. Then ω_{FE} is the terminal object of \mathbf{Cone}_{FE} . Thus ω_{FE} is the limit cone of FE . The components of ω_F and ω_{FE} have the same domain since ω_{FE} is a restriction of the components of ω_F . Therefore F and FE have the same limit.

EXERCISE 3.1.xii. What is the coproduct in the category of commutative rings?

The solution for this exercise requires tensor products of abelian groups. For the full solution, we will need to consider tensor products of arbitrary families of abelian groups. In writing this solution, I expand on ideas from the end of Chapter 2 of *Introduction to Commutative Algebra* by Atiyah and MacDonald, and Appendix A6.3 of *Commutative Algebra with a View Toward Algebraic Geometry* by Eisenbud.

In principal, we could just dive in and construct the coproduct of an arbitrary family of commutative rings. But, it is best to see how this works in the case of two commutative rings first.

So, in the first part of this solution we will take the following steps:

1. Describe the tensor product $A \otimes B$ of two abelian groups A and B .

2. Show that for two commutative rings R and S , the tensor product $R \otimes S$ of their additive groups has a well-defined multiplication law, making $R \otimes S$ a commutative ring. This is the trickiest part.
3. Describe ring homomorphisms from R and S to $R \otimes S$ and show that they satisfy the universal property for the coproduct in the category of commutative rings.

After all that hard work, we will do it over again for arbitrary families of abelian groups and arbitrary families of commutative rings.

Riehl introduces tensor products of \mathbb{k} -vector spaces in Example 2.3.7 and continues their discussion through Remark 2.3.11 and Exercise 2.3.ii. Although she does not show that tensor products exist (they do), she does derive a number of basic properties.

The entire discussion remains the same if \mathbb{k} -vector spaces are replaced by R -modules, where R is a commutative ring.⁵ Since we are only concerned with abelian groups, and abelian groups are \mathbb{Z} -modules, we may take $R = \mathbb{Z}$. This simplifies a few points, though the general case is not much harder.

For convenience, we will write all abelian groups additively. If C is a third abelian group, then a bilinear function

$$f : A \times B \rightarrow C$$

is as defined in Example 2.3.7 with "linear map" replaced by "group homomorphism". That is, we require that $f(a_1+a_2, b) = f(a_1, b)+f(a_2, b)$ and $f(a, b_1+b_2) = f(a, b_1)+f(a, b_2)$. It follows for any $n \in \mathbb{Z}$ that $f(na, b) = nf(a, b) = f(a, nb)$. If also $g : C \rightarrow D$ is a homomorphism of abelian groups, then it is easy to check that $gf : A \times B \rightarrow D$ is bilinear. So, we have a functor

$$\text{Bilin}(A, B; -) : \text{Ab} \rightarrow \text{Set}$$

where $\text{Bilin}(A, B; C)$ is the set of bilinear functions $f : A \times B \rightarrow C$. If $g : C \rightarrow D$ is as above, then post-composition gives a function $g_* : \text{Bilin}(A, B; C) \rightarrow \text{Bilin}(A, B; D)$, making $\text{Bilin}(A, B; -)$ a functor. Any abelian group representing this functor is the *tensor product* of A and B and has earned the right to be written as $A \otimes B$.

We now give a standard construction of the tensor product of two abelian groups A and B . Let F be the free abelian group whose basis is the set $A \times B$. That is, each element of F may be uniquely written as $\sum_{i=1}^n m_i(a_i, b_i)$ where $n \in \mathbb{N}$, $m_i \in \mathbb{Z}$ and $(a_1, b_1), \dots, (a_n, b_n)$ are distinct elements of $A \times B$. Let $K \subseteq F$ be the subgroup generated by

$$(a_1 + a_2, b) - (a_1, b) - (a_2, b) \text{ and } (a, b_1 + b_2) - (a, b_1) - (a, b_2)$$

for $a_1, a_2, a \in A$ and $b_1, b_2, b \in B$. The generators are precisely what we need to guarantee that

$$(a_1 + a_2, b) \equiv (a_1, b) + (a_2, b) \text{ and } (a, b_1 + b_2) \equiv (a, b_1) + (a, b_2)$$

modulo K . It follows that for each generator (a, b) of F and each integer $m \in \mathbb{Z}$,

$$(ma, b) \equiv m(a, b) \equiv (a, mb) \text{ modulo } K.$$

⁵Tensor products of modules for noncommutative rings are trickier and do not exist in the generality that we will discuss in the second half. See Jacobson's *Basic Algebra II* for basic information on tensor products of modules over noncommutative rings.

Write $A \otimes B$ for F/K . Write $a \otimes b$ for the congruence class of (a, b) in $A \otimes B$. Then we immediately have the following identities in $A \otimes B$, with $a, a_1, a_2, b, b_1, b_2, m$ as above:

$$(a_1+a_2) \otimes b = a_1 \otimes b + a_2 \otimes b, \quad a \otimes (b_1+b_2) = a \otimes b_1 + a \otimes b_2, \quad (ma) \otimes b = m(a \otimes b) = a \otimes (mb).$$

It follows that each element of $A \otimes B$ has a (non-unique) representation as

$$\sum_{i=1}^n a_i \otimes b_i.$$

An element of $A \otimes B$ of the form $a \otimes b$ is called a *simple tensor*.

Let $\otimes : A \times B \rightarrow A \otimes B$ be the function given by $\otimes(a, b) = a \otimes b$. Then the identities above show that \otimes is a bilinear function. It follows that for any morphism $g : A \otimes B \rightarrow C$ in \mathbf{Ab} , $g \circ \otimes : A \times B \rightarrow C$ is also bilinear. This is one direction of a natural bijection

$$\mathbf{Bilin}(A, B; C) \leftrightarrow \mathbf{Ab}(A \otimes B, C).$$

For the other direction, let $f : A \times B \rightarrow C$ be a bilinear function. I claim that there is a unique group homomorphism $\bar{f} : A \otimes B \rightarrow C$ such that $f = \bar{f} \circ \otimes$. For such an \bar{f} to exist, it would need to satisfy for every $a \in A$ and $b \in B$ that

$$f(a, b) = \bar{f} \circ \otimes(a, b) = \bar{f}(a \otimes b),$$

so there is at most one. To see that \bar{f} does exist, first define a group homomorphism $\tilde{f} : F \rightarrow C$ by $\tilde{f}((a, b)) = f(a, b)$. Such a homomorphism exists because F is free with basis consisting of all of the $(a, b) \in A \times B$. Since f is bilinear, each generator of K is in $\ker \tilde{f}$. So, $\tilde{f} : F \rightarrow C$ factors through F/K , and the induced map $\bar{f} : F/K \rightarrow C$ is $\bar{f}(a \otimes b) = f(a, b)$ as required.

Now, what does this have to do with the problem at hand? We will construct the coproduct of two commutative rings R and S as a commutative ring whose additive group is $R \otimes S$. While the multiplication law on $R \otimes S$ will seem obvious, the trick will be in seeing that it is well-defined.

We now carry out this construction. Let R and S be our rings and $R \otimes S$ be the tensor product of $(R, +)$ and $(S, +)$. Choose any $(r_1, s_1) \in R \times S$. Then we have a function

$$\mu_{(r_1, s_1)} : R \times S \rightarrow R \otimes S$$

taking $(r_2, s_2) \in R \times S$ to $r_1 r_2 \otimes s_1 s_2$. Using the distributive laws for R and S and the identities satisfied by \otimes , we see that $\mu_{(r_1, s_1)}$ is bilinear:

$$\begin{aligned} \mu_{(r_1, s_1)}(r_2 + r_3, s_2) &= r_1(r_2 + r_3) \otimes s_1 s_2 \\ &= (r_1 r_2 + r_1 r_3) \otimes s_1 s_2 \\ &= r_1 r_2 \otimes s_1 s_2 + r_1 r_3 \otimes s_1 s_2 \\ &= \mu_{(r_1, s_1)}(r_2, s_2) + \mu_{(r_1, s_1)}(r_3, s_2). \end{aligned}$$

Similarly, $\mu_{(r_1, s_1)}(r_2, s_2 + s_3) = \mu_{(r_1, s_1)}(r_2, s_2) + \mu_{(r_1, s_1)}(r_2, s_3)$. So, $\mu_{(r_1, s_1)}$ factors through a group homomorphism $R \otimes S \rightarrow R \otimes S$ taking $r_2 \otimes s_2$ to $r_1 r_2 \otimes s_1 s_2$.

Thus, we have a function $\mu : R \times S \times (R \otimes S)$ defined by $\mu(r_1, s_1, r_2 \otimes s_2) = r_1 r_2 \otimes s_1 s_2$. Arguing as above, we fix $r_2 \otimes s_2 \in R \otimes S$. Then $\mu(-, -, r_2 \otimes s_2) : R \times S \rightarrow R \otimes S$ is bilinear and thus factors through a homomorphism $R \otimes S \rightarrow R \otimes S$ taking (r_1, s_1) to $r_1 r_2 \otimes s_1 s_2$. Thus, μ induces a well-defined function

$$\bar{\mu} : (R \otimes S) \times (R \otimes S) \rightarrow R \otimes S$$

that on simple tensors is given by $\bar{\mu}(r_1 \otimes s_1, r_2 \otimes s_2) = r_1 r_2 \otimes s_1 s_2$. Furthermore, $\bar{\mu}$ is bilinear!

$\bar{\mu}$ is the multiplication of simple tensors on our putative ring $R \otimes S$. An arbitrary product is now given by

$$\left(\sum_{i=1}^m r_{1i} \otimes s_{1i} \right) \left(\sum_{j=1}^n r_{2j} \otimes s_{2j} \right) = \sum_{i=1}^m \sum_{j=1}^n r_{1i} r_{2j} \otimes s_{1i} s_{2j}.$$

Multiplication in $R \otimes S$ clearly distributes over addition in $R \otimes S$. It follows that multiplication is associative. Indeed the product of the three elements

$$\sum_{i=1}^m r_{1i} \otimes s_{1i}, \quad \sum_{j=1}^n r_{2j} \otimes s_{2j} \quad \text{and} \quad \sum_{k=1}^p r_{3k} \otimes s_{3k}$$

is equal to

$$\sum_{i=1}^m \sum_{j=1}^n \sum_{k=1}^p r_{1i} r_{2j} r_{3k} \otimes s_{1i} s_{2j} s_{3k}$$

no matter in what order the products are computed. The identity is $1 = 1 \otimes 1$, so that $R \otimes S$ is a monoid under multiplication. This is enough to see that $R \otimes S$ is a ring. That $R \otimes S$ is a commutative ring then follows from R and S being commutative.

Now, we must see that $R \otimes S$ has the right property to be a coproduct of R and S . First, consider the function $\iota_0 : R \rightarrow R \otimes S$ given by $\iota_0(r) = r \otimes 1$. Then

$$\begin{aligned} \iota_0(r_1 + r_2) &= (r_1 + r_2) \otimes 1 = r_1 \otimes 1 + r_2 \otimes 1 = \iota_0(r_1) + \iota_0(r_2), \\ \iota_0(r_1 r_2) &= (r_1 r_2) \otimes 1 = (r_1 \otimes 1)(r_2 \otimes 1) = \iota_0(r_1) \iota_0(r_2), \\ \iota_0(1) &= 1 \otimes 1 = 1. \end{aligned}$$

So, ι_0 is a ring homomorphism. Similarly, we have a ring homomorphism $\iota_1 : S \rightarrow R \otimes S$ given by $\iota_1(s) = 1 \otimes s$.

Finally, we must check the universal property. Let T be a third commutative ring and let $f : R \rightarrow T$ and $g : S \rightarrow T$ be ring homomorphisms. Considering R , S and T under addition, the function $(f * g) : R \times S \rightarrow T$ defined by $(f * g)(r, s) = f(r)g(s)$ is bilinear, as may be readily checked from the distributive law in T and that f and g are homomorphisms for $+$. So, $f * g$ factors through a homomorphism $h : R \otimes S \rightarrow T$ on the additive groups given on simple tensors by $h(r \otimes s) = f(r)g(s)$. It is readily seen from the commutativity of T that this is also a homomorphism for multiplication, so that h is a ring homomorphism. Since $h \iota_0(r) = h(r \otimes 1) = f(r)g(1) = f(r)$ and $h \iota_1(s) = h(1 \otimes s) = f(1)g(s) = g(s)$, $R \otimes S$ satisfies the universal property of the coproduct in the category of commutative rings.

Now, let's do it again for arbitrary families of commutative rings. We will perform the following steps.

1. Describe the tensor product $\bigotimes_{j \in J} A_j$ of an arbitrary family of abelian groups $(A_j)_{j \in J}$.
2. Show that for a family of commutative rings $(R_j)_{j \in J}$, the tensor product $R = \bigotimes_{j \in J} R_j$ of their additive groups admits a multiplication law making R into a commutative ring. This is a little tricky, but is similar to the case of the tensor product of two rings above.
3. Describe a natural family of ring homomorphisms $R_j \rightarrow R$ that will make R the coproduct if J is finite.
4. Describe a subring R' of R that is the coproduct of the R_j even when J is not finite. This part requires some care, but is reminiscent of the direct sum (coproduct) of a family of modules being a submodule of the direct product (product) of that same family.

Let J be a set, viewed as a small discrete category, and consider a family A_j of abelian groups indexed by $j \in J$. Let

$$f : \prod_{j \in J} A_j \rightarrow C$$

be a function to an abelian group C , where $\prod_{j \in J} A_j$ is the Cartesian product of the sets A_j . Consider some $i \in J$ and a choice of fixed values $a_j \in A_j$ for $j \neq i$ and let $\alpha : A_i \rightarrow \prod_{j \in J} A_j$ be the function such that $\alpha(a) = (a_j)_{j \in J}$ where $a_j = a$ if $j = i$, and is the chosen fixed value otherwise. If for every choice of $i \in J$ and fixed values $a_j \in A_j$ for $j \neq i$ the composition $f \circ \alpha : A_i \rightarrow C$ is a group homomorphism, then f is called a *J-linear function*.

Before going on, let's check what happens when J has no more than 2 elements. If $J = \emptyset$, then $\prod_{j \in \emptyset} A_j$ is a singleton set – a terminal object in **Set**. The conditions above on f are vacuous, so we simply require a function $f : \{*\} \rightarrow C$, which is determined by a choice of element $c \in C$. If J is a singleton set, then our product is just an abelian group $A_i = A$. There are no other $j \in J$, so that the choice of fixed values $a_j \in A_j$ is vacuous so that the condition on $f : A \rightarrow C$ is that it is a group homomorphism. If J has two elements, then the condition of being a J -linear function is the condition of being a bilinear function considered above.

Just as for bilinear functions, we have for a J -linear function $f : \prod_{j \in J} A_j \rightarrow C$ and a group homomorphism $g : C \rightarrow D$ that $g \circ f : \prod_{j \in J} A_j \rightarrow D$ is also J -linear. Thus, for a J -indexed family of abelian groups $(A_j)_{j \in J}$ we have a functor

$$J\text{-lin}((A_j)_{j \in J}; -) : \mathbf{Ab} \rightarrow \mathbf{Set}$$

taking C to the set of J -linear functions from $\prod_{j \in J} A_j$ to C and taking a group homomorphism $g : C \rightarrow D$ to postcomposition g_* . Any group representing this functor is the *tensor product* of this family of groups $(A_j)_{j \in J}$ and is denoted

$$\bigotimes_{j \in J} A_j.$$

Let's follow up on the basic cases above. If $J = \emptyset$, then $\emptyset\text{-lin}(\cdot; -)$ is naturally isomorphic to the forgetful functor $U : \mathbf{Ab} \rightarrow \mathbf{Set}$, which is represented by \mathbb{Z} . So, an empty tensor product is equal to \mathbb{Z} . If J is a singleton set, then $1\text{-lin}(A; -) \simeq \mathbf{Ab}(A, -)$ which is tautologically represented by A . So, a tensor product of a single abelian group is that abelian group. The tensor product of two abelian groups is as we considered above.

Now, we imitate the construction of a tensor product of two abelian groups to give the tensor product of an arbitrary family of abelian groups. Given a family $(A_j)_{j \in J}$ of abelian groups, let F be the free abelian group whose basis is the elements of $\prod_{j \in J} A_j$. Thus, each element of F may be uniquely expressed as $\sum_{i=1}^n m_i (a_{ij})_{j \in J}$ where $n \in \mathbb{N}$, $m_i \in \mathbb{Z}$ and $(a_{1j})_{j \in J}, \dots, (a_{nj})_{j \in J}$ are distinct elements of $\prod_{j \in J} A_j$.

Let $K \subseteq F$ be the subgroup generated by all expressions of the form

$$(a_j)_{j \in J} - (b_j)_{j \in J} - (c_j)_{j \in J}$$

such that there is some $i \in J$ for which $a_i = b_i + c_i$ and $a_j = b_j = c_j$ for all $j \neq i$. Write $\bigotimes_{j \in J} A_j$ for F/K and $\otimes_{j \in J} a_j$ for the image of the basis element $(a_j)_{j \in J}$ in $\bigotimes_{j \in J} A_j$. This image is called a *simple tensor*. So long as $J \neq \emptyset$, any integer multiple of a simple tensor $m(\otimes_{j \in J} a_j)$ may also be written as a simple tensor by choosing some j and replacing a_j by ma_j . Then, for $J \neq \emptyset$, each element of $\bigotimes_{j \in J} A_j$ may be represented (non-uniquely) as a finite sum of simple tensors⁶:

$$\sum_{i=1}^n \otimes_{j \in J} a_{ij}.$$

The choice of K makes it so that the function

$$\otimes : \prod_{j \in J} A_j \rightarrow \bigotimes_{j \in J} A_j$$

taking $(a_j)_{j \in J}$ to $\otimes_{j \in J} a_j$ is J -linear. If $f : \prod_{j \in J} A_j \rightarrow C$ is another J -linear function to an abelian group C , then we wish to produce a homomorphism $\tilde{f} : \bigotimes_{j \in J} A_j \rightarrow C$ such that $f = \tilde{f} \circ \otimes$. The only possibility is for $\tilde{f}(\otimes a_j) = f(\otimes(a_j))$. We must see that this is a well-defined group homomorphism.

Using that F is free on a basis consisting of $(a_j)_{j \in J}$, we have a unique group homomorphism $\tilde{f} : F \rightarrow C$ extending f given by $\tilde{f}((a_j)) = f(\otimes(a_j))$. The J -linearity of f shows that $K \subseteq \ker \tilde{f}$, so that \tilde{f} factors uniquely through $\tilde{f} : F/K \rightarrow C$ as required.

This gives us a natural bijection

$$J\text{-lin}((A_j)_{j \in J}; C) \leftrightarrow \mathbf{Ab}\left(\bigotimes_{j \in J} A_j, C\right)$$

showing that $\bigotimes_{j \in J} A_j$ represents $J\text{-lin}((A_j); -)$. This justifies that our construction creates a tensor product.

⁶If $J = \emptyset$, then every element of $\bigotimes_{j \in \emptyset} A_j$ is an integer multiple of the unique empty simple tensor. We will assume that $J \neq \emptyset$ going forwards, but the modifications required for the empty case are straightforward.

Now, let $(R_j)_{j \in J}$ be a family of commutative rings and let $R = \bigotimes_{j \in J} R_j$ be the tensor product of their underlying abelian groups. We will construct a multiplication operation on R that makes R into a ring.

This multiplication operation will be built from the function

$$\mu : \prod_{j \in J} R_j \times \prod_{j \in J} R_j \rightarrow R = \bigotimes_{j \in J} R_j$$

defined by $\mu((a_j), (b_j)) = \otimes_j (a_j b_j)$. Notice that if we fix the lefthand side $a = (a_j)_{j \in J}$, then the function $\mu_a : \prod_j R_j \rightarrow R$ given by $\mu_a((b_j)) = \otimes_j (a_j b_j)$ is J -linear. To check this, let $(b_j), (b'_j), (b''_j) \in \prod_j R_j$ be such that there is some $i \in J$ such that $b_i = b'_i + b''_i$ while $b_j = b'_j = b''_j$ for $j \neq i$. Then the i -component of $\otimes_j (a_j b_j)$ is $a_i b_i = a_i b'_i + a_i b''_i$ so that

$$\otimes_{j \in J} (a_j b_j) = \otimes_{j \in J} a_j b'_j + \otimes_{j \in J} a_j b''_j$$

as required.

So, μ_a factors uniquely through a group homomorphism $\bar{\mu}_a : R \rightarrow R$ for which $\bar{\mu}_a(\otimes_j b_j) = \otimes_j (a_j b_j)$. For arbitrary elements of R , this becomes

$$\bar{\mu}_a : \sum_{k=1}^n \otimes_{j \in J} b_{kj} \mapsto \sum_{k=1}^n \otimes_{j \in J} (a_j b_{kj}).$$

So, we have a well-defined function

$$\hat{\mu} : \left(\prod_{j \in J} R_j \right) \times R \rightarrow R$$

given by

$$\left((a_j)_{j \in J}, \sum_{k=1}^n \otimes_{j \in J} b_{kj} \right) \mapsto \sum_{k=1}^n \otimes_{j \in J} (a_j b_{kj}).$$

Fixing the right-hand side $b = \sum_{k=1}^n \otimes_j b_{kj}$ we obtain a function

$$\hat{\mu}_b : \prod_{j \in J} R_j \rightarrow R$$

given by

$$(a_j)_{j \in J} \mapsto \sum_{k=1}^n \otimes_{j \in J} (a_j b_{kj}).$$

As above, this is a J -linear function and so factors through a function $\bar{\mu}_b : R \rightarrow R$ that when applied to an arbitrary element of R is given by

$$\bar{\mu}_b : \sum_{i=1}^m \otimes_j a_{ij} \mapsto \sum_{i=1}^m \sum_{k=1}^n \otimes_j (a_{ij} b_{kj}).$$

Letting $b \in R$ vary, we obtain a well-defined function $\bar{\mu} : R \times R \rightarrow R$

$$\bar{\mu} \left(\sum_{i=1}^m \otimes_j a_{ij}, \sum_{k=1}^n \otimes_j b_{kj} \right) = \sum_{i=1}^m \sum_{k=1}^n \otimes_j (a_{ij} b_{kj}).$$

As in the earlier case of a tensor product of two rings, it is easy to check that μ is an associative and commutative binary operation that distributes over addition in R . Furthermore, $1 := \otimes_j 1$ is a multiplicative identity for μ , so that R is a commutative ring.

For each $i \in J$, let $\tilde{\iota}_i : R_i \rightarrow R$ be the function defined by $\tilde{\iota}_i(a) = \otimes_j a_j$ where $a_i = a$ and $a_j = 1 \in R_j$ for $j \neq i$. Then the basic properties of the tensor product show that $\tilde{\iota}_i(a + b) = \tilde{\iota}_i(a) + \tilde{\iota}_i(b)$. The multiplication law described above shows that $\tilde{\iota}_i(ab) = \tilde{\iota}_i(a)\tilde{\iota}_i(b)$. Finally, $\tilde{\iota}_i(1) = 1$. So, $\tilde{\iota}_i$ is a ring homomorphism.

However, R equipped with the homomorphisms $\tilde{\iota}_j$ is not in general the coproduct of the R_j ! Let $R' \subseteq R$ be the smallest subring of R that contains all of the images of the $\tilde{\iota}_j$. (This should remind you of direct sums of modules) That is,

$$R' = \left\{ \sum_{i=1}^m \otimes_j a_{ij} \mid a_{ij} = 1 \text{ for all but finitely many } a_{ij} \right\}.$$

(If J is finite, then $R' = R$.) Then each $\tilde{\iota}_i$ factors uniquely and obviously through a ring homomorphism $\iota_i : R_i \rightarrow R'$ defined in the same way as $\tilde{\iota}_i$. Furthermore, note that for any simple tensor $\otimes_j a_j \in R'$, since $a_j = 1$ for all but finitely many j , it makes sense to write:

$$\otimes_j a_j = \prod_{j \in J} \iota_j(a_j).$$

The product is really a finite product, since only finitely many factors are not the identity element.

I claim that R' equipped with the homomorphisms $\iota_i : R_i \rightarrow R'$ is the coproduct of the family of commutative rings $(R_j)_{j \in J}$. To see this, let S be another commutative ring and let $\phi_i : R_i \rightarrow S$ be ring homomorphisms for $i \in J$. We must see that there is a unique ring homomorphism $\psi : R' \rightarrow S$ such that $\psi \iota_i = \phi_i$ for each $i \in J$. If there is any such ring homomorphism, then it must satisfy:

$$\psi \left(\sum_{i=1}^m \otimes_j a_{ij} \right) = \sum_{i=1}^m \psi(\otimes_j a_{ij}) = \sum_{i=1}^m \psi \left(\prod_{j \in J} \iota_j(a_{ij}) \right) = \sum_{i=1}^m \prod_{j \in J} \psi \iota_j(a_{ij}) = \sum_{i=1}^m \prod_{j \in J} \phi_j(a_{ij}).$$

This gives a formula for the only possible ring homomorphism $\psi : R' \rightarrow S$ satisfying our constraints. It remains to see that ψ is well-defined and really is a ring homomorphism.

The strategy that we would *like* to follow is to show that ψ is induced by a J -linear function $\prod_{j \in J} R_j \rightarrow S$ defined by $(a_j) \mapsto \prod_j \phi_j(a_j)$. This will work when J is finite, but this function is not defined on all of $\prod_j R_j$ when J is infinite! So, let us proceed with care.

For an element $(a_j) \in \prod_{j \in J} R_j$, say that the *support* of (a_j) is $\{j \in J \mid a_j \neq 1\}$. Say that (a_j) is of *finite support* if its support is a finite set and of *infinite support* if its support is an infinite set. Then $\prod_{j \in J} R_j$ is a disjoint union of the two subsets $(\prod_{j \in J} R_j)^f$ of elements of finite support and $(\prod_{j \in J} R_j)^\infty$ of elements of infinite support.

Recall that F is the free abelian group with basis $\prod_{j \in J} R_j$. Splitting the basis into these two subsets, we may write $F = F^f \oplus F^\infty$ where F^f is a free abelian group with basis $(\prod_{j \in J} R_j)^f$ and F^∞ is a free abelian group with basis $(\prod_{j \in J} R_j)^\infty$. Recall that $R = F/K$ where K is a subgroup that we will recall in a moment. Notice that R' is the image of F^f modulo K . The kernel of the induced group homomorphism $F^f \rightarrow R'$ is $F^f \cap K$, which we will call K^f . So, $R' \simeq F^f/K^f$.

Recall that $K \subseteq F$ is the subgroup generated by all expressions of the form

$$(a_j)_{j \in J} - (b_j)_{j \in J} - (c_j)_{j \in J}$$

such that there is some $i \in J$ for which $a_i = b_i + c_i$ and $a_j = b_j = c_j$ for all $j \neq i$. Notice that the supports of (a_j) , (b_j) and (c_j) in this expression can differ only in that i might be in some but not others. So, all three of (a_j) , (b_j) and (c_j) are in F^f or all three are in F^∞ . An arbitrary element of K^f is a sum of finitely many generators above or their inverses with the property that all terms with infinite support cancel out. We may split the sum into a sum of those generators involving terms of finite support and a sum of those generators involving terms of infinite support. The latter sum must be zero. So, we see that K^f is generated by expressions as above involving only terms of finite support.

To sum up, we have a homomorphism of abelian groups $\otimes : F^f \rightarrow R'$ given by $(a_j)_{j \in J} \mapsto \otimes_{j \in J} a_j$. The kernel \otimes is the subgroup K^f generated by expressions of the form

$$(a_j)_{j \in J} - (b_j)_{j \in J} - (c_j)_{j \in J}$$

such that there is some $i \in J$ for which $a_i = b_i + c_i$ and $a_j = b_j = c_j$ for all $j \neq i$ and (a_j) , (b_j) and (c_j) all have finite support.

Now, we do have a function $\tilde{\psi} : (\prod_{j \in J} R_j)^f \rightarrow S$ given by $\tilde{\psi}((a_j)) = \prod_{j \in J} \phi_j(a_j)$. This function is well-defined because each $(a_j) \in (\prod_{j \in J} R_j)^f$ has finite support and $\phi_j(1) = 1$. Since F^f is a free abelian group with basis $(\prod_{j \in J} R_j)^f$, $\tilde{\psi}$ induces a group homomorphism $\hat{\psi} : F^f \rightarrow S$ given by

$$\hat{\psi} \left(\sum_{i=1}^m \alpha_i (a_{ij})_{j \in J} \right) = \sum_{i=1}^m \alpha_i \tilde{\psi}((a_{ij})_{j \in J}) = \sum_{i=1}^m \alpha_i \prod_{j \in J} \phi_j(a_{ij}).$$

where $\alpha_i \in \mathbb{Z}$. To see that $\tilde{\psi}$ factors through $F^f/K^f \simeq R'$, we must check that each generator of K^f maps to 0. This follows from ϕ_i being a homomorphism on abelian groups and the distributive property of multiplication over addition in S .

This is enough to see that $\psi : R' \rightarrow S$ as given above is well-defined and is a homomorphism of abelian groups under addition. Now, we must see that it is also a homomorphism or monoids under multiplication. First note that $\psi(1) = \prod_{j \in J} \phi_j(1) = 1$ so that ψ preserves the identity. Now, we check directly that ψ preserves multiplication:

$$\psi \left(\sum_{i=1}^m \otimes_j a_{ij} \right) \psi \left(\sum_{k=1}^n \otimes_j b_{kj} \right) = \left(\sum_{i=1}^m \prod_{j \in J} \phi_j(a_{ij}) \right) \left(\sum_{k=1}^n \prod_{j \in J} \phi_j(b_{kj}) \right)$$

$$= \sum_{i=1}^m \sum_{k=1}^n \prod_{j \in J} \phi_j(a_{ij}) \phi_j(b_{kj}) = \sum_{i=1}^m \sum_{k=1}^n \prod_{j \in J} \phi_j(a_{ij} b_{kj}) = \psi \left(\sum_{i=1}^m \sum_{k=1}^n \otimes_j (a_{ij} b_{kj}) \right).$$

Now, we have seen that for any family of ring homomorphisms $\phi_j : R_j \rightarrow S$ there is a unique ring homomorphism $\psi : R' \rightarrow S$ such that $\phi_j = \psi \iota_j$ for every $j \in J$. Thus, R' is the coproduct of the R_j and we may write $R' = \coprod_{j \in J} R_j \subseteq \otimes_{j \in J} R_j$ with a clean conscience.

3.2 Limits in the category of sets

EXERCISE 3.2.i. A **small category** can be redefined to be a particular diagram in \mathbf{Set} . The data is given by a pair of suggestively-named sets with functions

$$\text{mor } \mathbf{C} \begin{array}{c} \xrightarrow{\text{dom}} \\ \xleftarrow{\text{id}} \\ \xrightarrow{\text{cod}} \end{array} \text{ob } \mathbf{C}$$

together with a “composition function” yet to be defined. Use a pullback to define the set of composable pairs of morphisms, which serves as the domain for the composition function, and formulate the axioms for a category using commutative diagrams in \mathbf{Set} . When \mathbf{Set} is replaced by a category \mathbf{E} with pullbacks, this defines a **category internal to \mathbf{E}** .

For the sake of concision we introduce the aliases: $\mathcal{O} = \text{ob } \mathbf{C}$ and $\mathcal{M} = \text{mor } \mathbf{C}$. Pullbacks in \mathbf{Set} are realized by subsets of the Cartesian product on which two functions agree. In this case we have

$$\begin{array}{ccc} \mathcal{M} \times_{\mathcal{O}} \mathcal{M} & \xrightarrow{\pi_2} & \mathcal{M} \\ \pi_1 \downarrow & \lrcorner & \downarrow \text{dom} \\ \mathcal{M} & \xrightarrow{\text{cod}} & \mathcal{O} \end{array}$$

where

$$\mathcal{M} \times_{\mathcal{O}} \mathcal{M} = \{ (f, g) \in \text{mor } \mathbf{C}^2 \mid \text{cod}(f) = \text{dom}(g) \},$$

and π_1 and π_2 are the expected projection maps out of $\mathcal{M} \times_{\mathcal{O}} \mathcal{M}$. This set contains precisely the ordered pairs (f, g) for which the composition gf is defined. Composition is thus rendered as a function $\mu: \mathcal{M} \times_{\mathcal{O}} \mathcal{M} \rightarrow \mathcal{M}$. We can then describe the axioms of a category as commutative diagrams involving μ , cod , dom , id , and products thereof.

First, given composable morphisms f and g as above, we have $\text{dom}(f) = \text{dom}(gf)$ and $\text{cod}(g) = \text{cod}(gf)$. In other words $\text{dom } \pi_1 = \text{dom } \mu$ and $\text{cod } \pi_2 = \text{cod } \mu$.

$$\mathcal{M} \times_{\mathcal{O}} \mathcal{M} \begin{array}{c} \xrightarrow{\pi_1} \\ \xrightarrow{\mu} \end{array} \mathcal{M} \xrightarrow{\text{dom}} \mathcal{O} \quad \text{and} \quad \mathcal{M} \times_{\mathcal{O}} \mathcal{M} \begin{array}{c} \xrightarrow{\pi_2} \\ \xrightarrow{\mu} \end{array} \mathcal{M} \xrightarrow{\text{cod}} \mathcal{O}$$

Similarly, given an object c , the identity 1_c must satisfy $\text{dom}(1_c) = c = \text{cod}(1_c)$, i.e. $\text{dom } \text{id} = 1_{\mathcal{O}} = \text{cod } \text{id}$.

$$\begin{array}{ccc} \mathcal{O} & \xrightarrow{1_{\mathcal{O}}} & \mathcal{O} \\ \text{id} \searrow & & \nearrow \text{dom} \\ & \mathcal{M} & \nearrow \text{cod} \end{array}$$

To state the next two axioms we require more sophisticated pullbacks. First, we need ternary pullbacks. Let

$$\mathcal{M} \times_{\mathcal{O}} \mathcal{M} \times_{\mathcal{O}} \mathcal{M} = \{ (f, g, h) \mid \text{cod}(f) = \text{dom}(g) \text{ and } \text{cod}(g) = \text{dom}(h) \},$$

i.e. sets of composable triples, with projections $\pi_1, \pi_2,$ and π_3 into \mathcal{M} . It is easily seen that this is the pullback in two different diagrams.

$$\begin{array}{ccc} \mathcal{M} \times_{\mathcal{O}} \mathcal{M} \times_{\mathcal{O}} \mathcal{M} & \xrightarrow{\pi_3} & \mathcal{M} \\ \pi_1 \times \pi_2 \downarrow \lrcorner & & \downarrow \text{dom} \\ \mathcal{M} \times_{\mathcal{O}} \mathcal{M} & \xrightarrow{\text{cod } \pi_2} & \mathcal{O} \end{array} \quad \text{and} \quad \begin{array}{ccc} \mathcal{M} \times_{\mathcal{O}} \mathcal{M} \times_{\mathcal{O}} \mathcal{M} & \xrightarrow{\pi_2 \times \pi_3} & \mathcal{M} \times_{\mathcal{O}} \mathcal{M} \\ \pi_1 \downarrow \lrcorner & & \downarrow \text{dom } \pi_1 \\ \mathcal{M} & \xrightarrow{\text{cod}} & \mathcal{O} \end{array}$$

Because of our restriction the composite projections $\pi_1 \times \pi_2$ and $\pi_2 \times \pi_3$ give us valid composable pairs, so each is a legitimate map onto $\mathcal{M} \times_{\mathcal{O}} \mathcal{M}$.

The condition of associativity states that $h(gf) = (hg)f$ for any composable triple (f, g, h) , which we can now express diagrammatically.

$$\begin{array}{ccc} \mathcal{M} \times_{\mathcal{O}} \mathcal{M} \times_{\mathcal{O}} \mathcal{M} & \xrightarrow{\pi_1 \times \mu} & \mathcal{M} \times_{\mathcal{O}} \mathcal{M} \\ \mu \times \pi_3 \downarrow & & \downarrow \mu \\ \mathcal{M} \times_{\mathcal{O}} \mathcal{M} & \xrightarrow{\mu} & \mathcal{M} \end{array}$$

Finally, given any morphism f we have $\text{id}(\text{cod}(f))f = f = f \text{id}(\text{dom}(f))$. For this law we must consider the composable pairs containing identity morphisms. These can be isolated as the image of the following two pullbacks inside $\mathcal{M} \times_{\mathcal{O}} \mathcal{M}$.

$$\begin{array}{ccc} \mathcal{M} \times_{\mathcal{O}} \mathcal{O} & \xrightarrow{\pi_2} & \mathcal{O} \\ \pi_1 \downarrow \lrcorner & & \downarrow 1_{\mathcal{O}} \\ \mathcal{M} & \xrightarrow{\text{cod}} & \mathcal{O} \end{array} \quad \text{and} \quad \begin{array}{ccc} \mathcal{O} \times_{\mathcal{O}} \mathcal{M} & \xrightarrow{\pi_2} & \mathcal{M} \\ \pi_1 \downarrow \lrcorner & & \downarrow \text{dom} \\ \mathcal{O} & \xrightarrow{1_{\mathcal{O}}} & \mathcal{O} \end{array}$$

Equipped with these objects, we can express the identity law by the following commutative diagram.

$$\begin{array}{ccccc} \mathcal{M} \times_{\mathcal{O}} \mathcal{O} & \xrightarrow{\pi_1 \times \text{id}} & \mathcal{M} \times_{\mathcal{O}} \mathcal{M} & \xleftarrow{\text{id} \times \pi_2} & \mathcal{O} \times_{\mathcal{O}} \mathcal{M} \\ & \searrow \pi_1 & \downarrow \mu & \swarrow \pi_2 & \\ & & \mathcal{M} & & \end{array}$$

EXERCISE 3.2.ii. Show that for any small diagram $F: \mathbf{J} \rightarrow \mathbf{Set}$, the equalizer diagram (3.2.14) can be modified to yield a slightly smaller equalizer diagram:

Matt will add this diagram using TikZ

in which these condproduct is indexed only by non-identity morphisms.

PROOF. To show that we can slightly shrink the equalizer diagram, we will review the proof of Theorem 3.2.6 and notice that removing the objects from the second product does not lose any information. Recall that the objects of a category can be identified with their

identity morphisms. Notice that the cone over F is indexed by the non-identity elements. When f is an identity morphism the diagram

$$\begin{array}{ccc}
 & 1 & \\
 \lambda_{\text{cod } f} \swarrow & & \searrow \lambda_{\text{dom } f} \\
 F(\text{dom } f) & \xrightarrow{Ff} & F(\text{cod } f)
 \end{array}$$

collapses into a single line. Thus when defining the parallel pair of morphisms of c and d if f is an identity morphism (an object of \mathbf{J}) the legs of the cone are the same, so we do not lose any information excluding them. \square

EXERCISE 3.2.iii. For any pair of morphisms $f: a \rightarrow b$, $g: c \rightarrow d$ in a locally small category \mathbf{C} , construct the set of commutative squares

$$\text{Sq}(f, g) := \left\{ \begin{array}{ccc} a & \longrightarrow & c \\ f \downarrow & & \downarrow g \\ b & \longrightarrow & d \end{array} \right\}$$

from f to g as a pullback in \mathbf{Set} .

PROOF. Every commutative square in $\text{Sq}(f, g)$ takes the form

$$\begin{array}{ccc}
 a & \xrightarrow{p} & c \\
 f \downarrow & \searrow h & \downarrow g \\
 b & \xrightarrow{q} & d
 \end{array}$$

Let us now define $\text{DiagSq}(f, g)$ to contain each diagonal h for every commutative square in $\text{Sq}(f, g)$, $\text{TopSq}(f, g)$ to contain each top morphism p for every commutative square in $\text{Sq}(f, g)$, and $\text{BottSq}(f, g)$ to contain each bottom morphism q for every commutative square in $\text{Sq}(f, g)$. We will define functions $f^*: \text{BottSq}(f, g) \rightarrow \text{DiagSq}(f, g)$ and $g_*: \text{TopSq}(f, g) \rightarrow \text{DiagSq}(f, g)$ as precomposition by f and post-composition by g respectively. This gives us the diagram

$$\begin{array}{ccc}
 & \text{TopSq}(f, g) & \\
 & \downarrow g_* & \\
 \text{BottSq}(f, g) & \xrightarrow{f^*} & \text{DiagSq}(f, g)
 \end{array}$$

To show that $\text{Sq}(f, g)$ is the limit of the diagram, define the projections $\pi_1: \text{Sq}(f, g) \rightarrow \text{TopSq}(f, g)$ and $\pi_2: \text{Sq}(f, g) \rightarrow \text{BottSq}(f, g)$ as maps taking each commutative square

to their respective top morphism p and bottom morphism q respectively. It is easy to see that for $D \in \text{Sq}(f, g)$, $f^*(\pi_2(D)) = q \cdot f = h = g \cdot p = g_*(\pi_1(D))$, thus $g_* \cdot \pi_1 = f^* \cdot \pi_2$. Suppose S was a set with morphisms $s_1: S \rightarrow \text{TopSq}(f, g)$ and $s_2: S \rightarrow \text{BottSq}(f, g)$ such that $g_* \cdot s_1 = f^* \cdot s_2$. We need to find a unique morphism $s: S \rightarrow \text{Sq}(f, g)$ such that $s_1(x) = \pi_1(s(x))$ and $s_2(x) = \pi_2(s(x))$ for every element $x \in S$. Such a morphism can be defined as the function that maps each element x to the commutative square whose top morphism is $s_1(x)$ and bottom morphism is $s_2(x)$. Uniqueness of s follows from the fact that for any $x \in S$ there is only one commutative square with a top morphism $s_1(x)$ and bottom morphism $s_2(x)$. Thus we can construct $\text{Sq}(f, g)$ from a pullback in Set .

EXERCISE 3.2.iv. Generalize Exercise 3.2.iii to show that for any small category \mathbf{J} , any locally small category \mathbf{C} and any parallel pair of functors $F, G: \mathbf{J} \rightarrow \mathbf{C}$, the set $\text{Hom}(F, G)$ of natural transformations can be defined as a small limit in Set . (Hint: the diagram whose limit is $\text{Hom}(F, G)$ is indexed by a category \mathbf{J}^\S whose objects are morphisms in \mathbf{J} and which had morphisms $1_x \rightarrow f, 1_y \rightarrow f$ for every $f: x \rightarrow y$ in \mathbf{J})

PROOF. First, we note that the underlying shape of the diagram in Set will be based on the following diagram in \mathbf{J}^\S :

$$1_x \longrightarrow f \longleftarrow 1_y \quad (3.4)$$

Now, we define a functor $H: \mathbf{J}^\S \rightarrow \mathbf{C}$ as the following:

- For $f \in \text{ob}\mathbf{J}^\S$ where $f: x \rightarrow y$, $Hf = \mathbf{C}(Fx, Gy)$
- For a morphism $\tau: 1_x \rightarrow f$ in \mathbf{J}^\S where $f: x \rightarrow y$, $H\tau: \mathbf{C}(Fx, Gx) \rightarrow \mathbf{C}(Fx, Gy)$ is defined as post-composition by Gf and if $\tau: 1_y \rightarrow f$, $H\tau: \mathbf{C}(Fy, Gy) \rightarrow \mathbf{C}(Fx, Gy)$ is defined as precomposition by Gf .

We see that the image of (1) under this functor is :

$$\mathbf{C}(Fx, Gx) \xrightarrow{Gf \circ -} \mathbf{C}(Fx, Gy) \xleftarrow{- \circ Ff} \mathbf{C}(Fy, Gy) \quad (3.5)$$

Now, we must show that $\text{Hom}(F, G)$ is a cone over this diagram. To do this, we construct a family of functions $\phi_{xy}: \text{Hom}(F, G) \rightarrow \mathbf{C}(Fx, Gy)$ where $\phi_{xy}(\eta) = \eta_x$, the corresponding component of the natural transformation (if this is the case, we denote it as ϕ_x if $x = y$ and $\phi_{xy}(\eta) = Gf\eta_x$ if $x \neq y$). Because we have that η is a natural transformation and that $Gf\eta_x = \eta_y Ff$, we see that we have commutativity of:

$$\begin{array}{ccc} & \text{Hom}(F, G) & \\ \phi_x \swarrow & \downarrow \phi_{xy} & \searrow \phi_y \\ \mathbf{C}(Fx, Gx) & \xrightarrow{Gf \circ -} \mathbf{C}(Fx, Gy) \xleftarrow{- \circ Ff} \mathbf{C}(Fy, Gy) & \end{array} \quad (3.6)$$

Now, we must show that $\text{Hom}(F, G)$ is the limit for this diagram. Suppose that there is an object $X \in \text{Set}$ that also forms a cone over our diagram. This means that for every object $f \in \mathcal{J}^{\mathfrak{S}}$ and $Hf = \mathbf{C}(Fx, Gy)$, we have a $\sigma_{x,y}: X \rightarrow \mathbf{C}(Fx, Gy)$ so that $\sigma_{xy}(k): Fx \rightarrow Gy$ and in particular, if $x = y$, then $\sigma_x(k): Fx \rightarrow Gx$. Now, suppose we have a $r: X \rightarrow \text{Hom}(F, G)$, such that $\sigma_x = \phi_x r$. So for $k \in X$ $\phi_x r(k) = \sigma_x(k)$. Now, consider that ϕ_x is selecting the x component of the natural transformation $r(k)$, so $(r(k))_x = \sigma_x(k)$. So, we see what the construction of r must be. This is the only possible construction that satisfies $\phi_x r = \sigma_x$. We can also easily see that $\phi_{xy} r = \sigma_{xy}$ with our construction of r . So we have shown that any cone with apex X factors uniquely through $\text{Hom}(F, G)$ and so $\text{Hom}(F, G)$ is the limit of this diagram.

EXERCISE 3.2.v. Show that for any small category \mathcal{J} , any locally small category \mathbf{C} , and any parallel pair of functors $F, G: \mathcal{J} \rightrightarrows \mathbf{C}$, there is an equalizer diagram

$$\begin{array}{ccc}
 \mathbf{C}(Fj', Gj') & \xrightarrow{Ff^*} & \mathbf{C}(Fj, Gj') \\
 \pi_{j'} \uparrow & & \uparrow \pi_f \\
 \text{Hom}(F, G) \hookrightarrow \prod_{j \in \text{obj } \mathcal{J}} \mathbf{C}(Fj, Gj) & \rightrightarrows & \prod_{f: j \rightarrow j' \in \text{mor } \mathcal{J}} \mathbf{C}(Fj, Gj') \\
 \pi_j \downarrow & & \downarrow \pi_f \\
 \mathbf{C}(Fj, Gj) & \xrightarrow{Gf_*} & \mathbf{C}(Fj, Gj')
 \end{array}$$

Note that this is not the equalizer diagram obtained by applying Theorem 3.2.13 to the diagram constructed in Exercise 3.2.vi. Rather, this construction gives a second formula for $\text{Hom}(F, G)$ as a limit in Set .

PROOF. Our strategy will be to determine the parallel morphisms in the middle of the diagram, and then use those to determine an equalizer. From there, we will show that this equalizer is isomorphic to $\text{Hom}(F, G)$, and thus the diagram is an equalizer diagram.

Let a, b be the parallel functions from the above diagram. We have that $\pi_f a = Ff^* \pi_{j'}$ and $\pi_f b = Gf_* \pi_j$. We can describe the action of the top half of the diagram as taking the j' component of the product into a morphism $m_{j'}: Fj' \rightarrow Gj'$, and then precomposing m with f . Similarly, the bottom of the diagram post-composes f with $n_j: Fj \rightarrow Gj$. We then have that $\pi_f a = (m_{j'} \circ f) \pi_{j'}$ and $\pi_f b = (f \circ n_j) \pi_j$. So a and b take products of morphisms indexed by j to products of morphisms that have been pre and post-composed (respectively) with the morphisms $f: j \rightarrow j' \in \mathcal{J}$. The equalizer in this case would be the products of morphisms the components of which are the same under both pre and post-composition with f :

$$\left\{ p \in \prod_{j \in \text{obj } \mathcal{J}} \mathbf{C}(Fj, Gj) \mid f \circ g_i = g_i \circ f \text{ for all } g_i \in p \right\}$$

Where $g_i: Fj \rightarrow Gj$ is the i -th component of p .

Note that this is similar to the condition of naturality, that the following diagram commutes for a natural transformation α with componenets α_j :

$$\begin{array}{ccc} Fj & \xrightarrow{Ff} & Fj' \\ \alpha_j \downarrow & & \downarrow \alpha_{j'} \\ Gj & \xrightarrow{Gf} & Gj' \end{array}$$

Where we can see that $Gf \circ \alpha_j = \alpha_{j'} \circ Ff$. An element p of the equalizer is a product of morphisms between Fj and Gj , similar to α_j . Additionally, since there are as many products p as their are functions f , we can form a bijection between the equalizer and $\text{Hom}(F, G)$ by taking each product p to the natural transformation α for which $p_i = \alpha_i$. A morphism doing so is clearly injective and surjective, and thus we have a bijection (and since we are talking about sets, an isomorphism) between the equalizer and $\text{Hom}(F, G)$. So, the diagram is an equalizer diagram.

EXERCISE 3.2.vi. Prove that the limit of any small functor $F: \mathbf{C} \rightarrow \mathbf{Set}$ is isomorphic to the set of functors $\mathbf{C} \rightarrow \int F$ that defines a section to the canonical projection $\prod: \int F \rightarrow \mathbf{C}$ from the category of elements of F . Using this description of the limit, define the limit cone.

PROOF. Starting with the set of functors $\mathbf{C} \rightarrow \int F$, let ϕ be the functor $\mathbf{C} \rightarrow \int F$, which defines a setion to $\prod: \int F \rightarrow \mathbf{C}$, such that, for $\mathbf{C} \rightarrow \phi \int F \rightarrow \prod \mathbf{C}$, $\prod \phi = 1_{\mathbf{C}}$. Here, \prod is the forgetful functor, projecting (c, x) to c . Since $\prod \phi$ takes objects in \mathbf{C} to objects in \mathbf{C} , then the functor ϕ operates as an inclusion of objects c in \mathbf{C} into the category of elements, namely, $\phi = (c, x)$, for $x \in Fc$.

Since $\lim F \subset \prod_{j \in J} Fj$ is the set of tuples $\{(x_j)_{j \in J} | \forall f: j \rightarrow k \in J, Ff(x_j) = x_k \in Fk\}$. Then for $f: (c, x) \rightarrow (c', x')$, with $f: c \rightarrow c'$ in \mathbf{C} , such that $f(x) = x'$, $\prod \phi = 1_{\mathbf{C}}$. Thus $\lim F$ is isomorphic to the set of ϕ .

Also, since $\lim F \subset \prod Fc$, with $\lim F \rightarrow Fc$ and $\pi_c: \prod Fc \rightarrow Fc$, then this $\lim F$ is the limit cone. \square

3.3 Preservation, reflection, and creation of limits and colimits

EXERCISE 3.3.i. For any diagram $K: J \rightarrow C$ and any functor $F: C \rightarrow D$:

- (i) Define a canonical map $\text{colim} FK \rightarrow F \text{colim} K$, assuming both colimits exist.
- (ii) Show that the functor F preserves the colimit of K just when this map is an isomorphism.

PROOF (i). Let $\alpha: FK \Rightarrow \text{colim} FK$ be the colimit cone under FK . We also have following diagram for K and F :

$$\begin{array}{ccc} \begin{array}{c} \begin{array}{ccc} J & \xrightarrow{K} & C \\ \downarrow \mu & & \uparrow \\ \text{colim} K & & \end{array} \\ \end{array} & \xrightarrow{F} & \begin{array}{c} \begin{array}{ccc} J & \xrightarrow{FK} & D \\ \downarrow F\mu & & \uparrow \\ F \text{colim} K & & \end{array} \\ \end{array} \end{array}$$

This diagram gives us another cone $F\mu$ under FK . Then, the universal property tells us that since $F\mu$ is a cone with nadir $F \text{colim} K$, there must be a unique morphism $f: \text{colim} FK \rightarrow F \text{colim} K$ such that $F\mu = f\alpha$. \square

PROOF (ii). To see that F preserving colimits implies f is an isomorphism, note that for any cone $\beta: FK \Rightarrow z$, there is a unique morphism $k: F \text{colim} K \rightarrow z$ such that $\beta = kF\mu$ and that we also have a unique $j: \text{colim} FK \rightarrow z$ such that $\beta = j\alpha$. Since $F\mu$ is a cone $FK \Rightarrow F \text{colim} K$, then $k = 1_{F \text{colim} K}$ satisfies $F\mu = kF\mu$ and is the only such k . Similarly, $j = 1_{\text{colim} FK}$ is the only morphism such that $\alpha = j\alpha$. Then, if $\beta = \alpha$ (that is, it is the colimit cone under FK), then there must be some morphism $m: F \text{colim} K \rightarrow \text{colim} FK$ where $\alpha = mF\mu$. Similarly, $\beta = F\mu$ implies that there is some morphism $n: \text{colim} FK \rightarrow F \text{colim} K$ where $F\mu = n\alpha$. So, $F\mu = nmF\mu$ and $mn\alpha = \alpha$. Since we already know which morphisms these are (j and k), we have $mn = j = 1_{\text{colim} FK}$ and $nm = k = 1_{F \text{colim} K}$ and so m and n are inverses of each other. Thus, f is an isomorphism (with $f = n$ and $f^{-1} = m$).

Conversely, we need to show that $F \text{colim} K$ satisfies the universal property if f^{-1} exists. That is, for any cone $\beta: FK \Rightarrow a$, there exists a unique morphism $m: F \text{colim} K \rightarrow a$, so the following diagram gives us a construction for a morphism $F \text{colim} K \rightarrow a$:

$$\begin{array}{ccc} FK & \xrightarrow{\beta} & a \\ & \searrow F\mu & \uparrow m \\ & & \text{colim} FK \\ & & \xrightarrow{f} F \text{colim} K \\ & & \xleftarrow{f^{-1}} \end{array}$$

$m \circ f^{-1}$ (curved arrow from $F \text{colim} K$ to a)

The universal morphism is $m \circ f^{-1}$, which is unique since m and f^{-1} are both unique, and so F preserves colimits. \square

EXERCISE 3.3.ii. Prove that a full and faithful functor reflects both limits and colimits.

PROOF. Let $F : C \rightarrow D$ be fully faithful, and let $\lambda : c \Rightarrow K$ be a cone over some diagram $K : J \rightarrow C$ such that $F\lambda : Fc \Rightarrow FK$ is a limit cone in D . Finally, let $\gamma : d \Rightarrow K$ be an arbitrary cone over K in C . $F\gamma : Fd \Rightarrow FK$ is necessarily a cone in D , so there must be a unique morphism $g : Fd \rightarrow Fc$ such that $F\gamma = F\lambda g$. Since F is fully faithful, there must be a unique $f \in C$ such that $Ff = g$.

Furthermore, for any morphism $h : d \rightarrow c$ such that $\gamma = \lambda h$, $F\gamma = F\lambda Fh$. But recall that g is the unique morphism such that $F\lambda g = F\gamma$, so $g = Fh$. Finally recall that since F is fully faithful, f is the unique morphism such that $g = Ff$, so $f = h$. So the $f : d \rightarrow c$ constructed earlier is unique for each cone γ over K in C , which means λ must be a limit cone. So F reflects limits.

Similarly, if we let $F\lambda : FK \Rightarrow Fc$ be a colimit cone under FK and $\gamma : K \Rightarrow d$ be a cone under K , we can use the dual of the above procedure to construct a unique $f \in C$ such that $F\gamma = FfF\lambda = F(f\lambda)$ and therefore that $\gamma = f\lambda$, making λ a colimit cone under K . So F also reflects colimits. \square

EXERCISE 3.3.iii. Prove Lemma 3.3.6, that an equivalence of categories, reflects and creates any limits and colimits that are present in either its domain or codomain.

PROOF. If two categories C and D are equivalent, then there is a full faithful and essentially surjective functor $F : C \rightarrow D$. By the previous question F reflects limits. Let G be cone over a diagram $H : J \rightarrow C$ with apex c in C . We need to show that FG is a cone in D . Since G is a cone we have the following commutative triangle

$$\begin{array}{ccc} & c & \\ \lambda_k \swarrow & & \searrow \lambda_j \\ Hj & \xrightarrow{Hf} & Hk \end{array}$$

where $(\lambda_j : c \rightarrow Hj)_{j \in \text{obj } J}$ and $f : j \rightarrow k$ is a morphism in J . Since F is faithful, F uniquely maps f in $\text{mor } J$ and λ_j to Ff and $F\lambda_j$, respectively. Since G is a cone in C and F respects composition we know that the following diagram commutes.

$$\begin{array}{ccc} & Fc & \\ F\lambda_k \swarrow & & \searrow F\lambda_j \\ FHj & \xrightarrow{FHf} & FHk \end{array}$$

Thus F preserves cones, and therefore preserves limits. Because F is full and faithful, by exercise 1.5.iv F reflects isomorphisms. This fulfills the criteria to apply the next question 3.3.iv, so F creates limits. This completes the proof. \square

EXERCISE 3.3.iv. Prove that $F: \mathbf{C} \rightarrow \mathbf{D}$ creates limits for a particular class of diagrams if both of the following hold:

1. \mathbf{C} has those limits and F preserves them.
2. $F: \mathbf{C} \rightarrow \mathbf{D}$ reflects isomorphisms.

PROOF. The first condition above means that for every $K: \mathbf{J} \rightarrow \mathbf{C}$, K has a limit whose limit cone is represented by $\lambda: \lim K \Rightarrow K$ and that $F\lambda: F \lim K \Rightarrow FK$ is a limit cone for FK . The second condition means that for every morphism f in \mathbf{C} , if Ff is an isomorphism in \mathbf{D} , then so is f .

We must show that whenever $FK: \mathbf{J} \rightarrow \mathbf{D}$ has a limit in \mathbf{D} , there is some limit cone over FK that can be lifted to a limit cone over K and that F reflects all limits. To see the first requirement, we see that for any K , there exists a limit cone $F\lambda$ as defined before by condition 1 that can be lifted to a limit cone λ over K . We now must show that F reflects all limits.

Now suppose that $\nu: c \Rightarrow K$ is a cone over K and that $F\nu: Fc \Rightarrow FK$ is a limit cone. Note that we also have the limit cone $F\lambda: F \lim K \Rightarrow FK$. Consider the unique morphism $f: Fc \rightarrow F \lim K$ such that $(F\lambda)f = F\nu$. We know that f is an isomorphism, because $F\nu$ is also a limit cone. We must now show that this isomorphism is in the image of F , that is that $f = Fg$ for some $g: c \rightarrow \lim K$. We see that this morphism is the image of the unique morphism that factors the legs of ν through λ by the uniqueness of f .

So we see that $Fg = f$ is an canonical isomorphism in \mathbf{D} , and therefore by our second condition that F reflect isomorphisms, g is a canonical isomorphism between c and $\lim K$, so we see that ν is also a limit cone over K . Therefore F reflects limits and we have shown that F creates limits. \square

EXERCISE 3.3.v. Show that the forgetful functors $U: \mathbf{Set}_* \rightarrow \mathbf{Set}$ and $U: \mathbf{Top}_* \rightarrow \mathbf{Top}$ fail to preserve coproducts and explain why this results demonstrates that the connectedness hypothesis in Proposition 3.3.8(ii) is necessary.

PROOF. Consider first pointed sets (A, a) and (B, b) where neither is a singleton. Letting $C := (A \setminus \{a\}) \amalg (B \setminus \{b\})$, then $(C, *)$, where $*$ is some available symbol, realizes the coproduct of (A, a) and (B, b) in \mathbf{Set}_* . The inclusion maps here are defined as they are for disjoint unions normally augmented by taking either a or b to $*$ as necessary. However, under the forgetful functor U , the coproduct of A and B is simply the disjoint union $A \amalg B$, which (with some fussing) properly contains C .

That this problem also affects topological spaces can be seen merely by noting that in taking finite sets with the discrete topology we have essentially recreated the category \mathbf{Fin} because all maps from a discrete space are continuous. Given more realistic topological spaces, the coproduct of two pointed spaces involves stitching them together at that point while the coproduct of the underlying spaces has them essentially floating free of each other.

To see why the connectedness hypothesis is necessary it is instructive to examine pushouts: where coproducts are the colimit of a diagram from a discrete category $\bullet \bullet$, pushouts are the colimit of a connected diagram $\bullet \leftarrow \bullet \rightarrow \bullet$. When we take a diagram of this form in \mathbf{Set}_* , we have two functions that preserve the points of each object: $f(c) = a$ and $g(c) = b$.

$$\begin{array}{ccc} (C, c) & \xrightarrow{f} & (B, b) \\ \downarrow g & & \\ (A, a) & & \end{array}$$

When we apply U and “forget” about the points, the functions f and g preserve their importance. For a set Z to be the colimit of this diagram in \mathbf{Set} with inclusions ι_A and ι_B , it must be the case $\iota_A f(c) = \iota_B g(c)$ which forces $\iota_A(a) = \iota_B(b)$. This is precisely the point at which U failed to preserve the coproduct.

EXERCISE 3.3.vi. Prove that for any small category A , the functor category C^A again has any limit or colimit that C does, constructed objectwise. That is given a diagram $F: J \rightarrow C^A$ with J small show that whenever the limits of the diagram

$$J \xrightarrow{F} C^A \xrightarrow{ev_a} C$$

exists in C for all $a \in A$, then these values define the action on object of $\lim F \in C^A$, a limit of the diagram F . (Hint: See Proposition 3.6.1)

PROOF. Suppose C has limits for each $a \in A$. For each $ev_a \cdot F$, call $\lim_a F \in C$ the limit of $ev_a \cdot F$. Now we will explicitly define an element of C^A which we will call $\lim F$:

1. $\lim F$ maps an object $a \in A$ to $\lim_a F$
2. suppose $m_{a_2}: \text{Cone}(-, ev_{a_2} \cdot F) \rightarrow C(-, \lim_{a_2} F)$ is the canonical natural isomorphism induced by the limit cone of $\lim_{a_2} F$. Then $\lim F$ maps morphism $f: a_1 \rightarrow a_2$ onto $m_{a_2, \lim_{a_1} F}(F_- f \cdot \lambda_{a_1})$ where λ_{a_1} is the limit cone of $\lim_{a_1} F$ and $F_- f$ is a natural transformation from $ev_{a_1} \cdot F$ to $ev_{a_2} \cdot F$ where the components are $F_j f$ for each j . The fact that $F_- f$ is a natural transformation follows from the fact that F maps each morphism of J to a natural transformation and ev_a simply maps a natural transformation to its component at a .

To verify that $\lim F$ is a functor note that each identity morphism 1_a gets mapped to $m_{a, \lim_a F}(\lambda_a) = 1_{\lim_a F}$ since $F_j 1_a$ is an identity morphism. Also, for morphisms $f: a_1 \rightarrow a_2$ and $g: a_2 \rightarrow a_3$, $\lim F$ maps $g \cdot f$ to $m_{a_3, \lim_{a_1} F}(F_-(g \cdot f) \cdot \lambda_{a_1}) =$

$m_{a_3, \lim_{a_1} F} (F_-g \cdot F_-f \cdot \lambda_{a_1})$. This induces the following commutative diagram

$$\begin{array}{ccc}
 \lim_{a_1} F & \xrightarrow{\lambda_{a_1, j}} & \text{ev}_{a_1} F j \\
 m_{a_2, \lim_{a_1} F} (F_j f \cdot \lambda_{a_1}) \downarrow & & \downarrow F_j f \\
 \lim_{a_2} F & \xrightarrow{\lambda_{a_2, j}} & \text{ev}_{a_2} F j \\
 m_{a_3, \lim_{a_2} F} (F_j g \cdot \lambda_{a_2}) \downarrow & & \downarrow F_j g \\
 \lim_{a_3} F & \xrightarrow{\lambda_{a_3, j}} & \text{ev}_{a_3} F j
 \end{array}$$

This shows that $m_{a_3, \lim_{a_1} F} (F_-g \cdot f \cdot \lambda_{a_1}) = m_{a_3, \lim_{a_2} F} (F_j g \cdot \lambda_{a_2}) \cdot m_{a_2, \lim_{a_1} F} (F_j f \cdot \lambda_{a_1})$, thus $\lim F(g \cdot f) = \lim Fg \cdot \lim Ff$. Now we must show that

$$\text{Cone}(-, F) \cong \mathcal{C}^A(-, \lim F)$$

Let ϕ be our proposed natural isomorphism where for $G \in \mathcal{C}^A$, $\phi_G: \text{Cone}(G, F) \rightarrow \mathcal{C}^A(G, \lim F)$ is defined as follows:

$$\phi_G(\alpha) = \{m_{a, G a}(\text{ev}_a \alpha) \mid a \in A\}$$

To show that $\phi_G(\alpha)$ can be regarded as a natural transformation we must show that the following diagram commutes:

$$\begin{array}{ccc}
 G a_1 & \xrightarrow{G f} & G a_2 \\
 m_{a_1, G a_1}(\text{ev}_{a_1} \alpha) \downarrow & & \downarrow m_{a_2, G a_2}(\text{ev}_{a_2} \alpha) \\
 \lim F a_1 & \xrightarrow{\lim F f} & \lim F a_2
 \end{array}$$

First thing to note is that $m_{a_2, G a_1} (F_-f \cdot \text{ev}_{a_1} \alpha) = \lim F f \cdot m_{a_1, G a_1} (\text{ev}_{a_1} \alpha)$ since $m_{a_2, \lim F a_1} = \lim F f$. As for $m_{a_2, \lim_{a_2} F} (\text{ev}_{a_2} \alpha) \cdot G f$, consider the cone β whose components are $\beta_j = \text{ev}_{a_2} \alpha_j \cdot G f$. Then $m_{a_2, G a_1} (\beta)$ must be equal to $m_{a_2, G a_2} (\text{ev}_{a_2} \alpha) \cdot G f$. We get that $\beta = F_-f \cdot \text{ev}_{a_1} \alpha$ since for each $a \in A$, $\text{ev}_a \alpha_j$ is the component of α_j at a , so we get that the following diagram commutes by naturality of α_j :

$$\begin{array}{ccc}
 G a_1 & \xrightarrow{G f} & G a_2 \\
 \text{ev}_{a_1} \alpha_j \downarrow & & \downarrow \text{ev}_{a_2} \alpha_j \\
 \text{ev}_{a_1} F j & \xrightarrow{F_j f} & \text{ev}_{a_2} F j
 \end{array}$$

. Thus the diagram for $\phi_G(\alpha)$ commutes confirming $\phi_G(\alpha)$ as a natural transformation. We must now show that ϕ_G is a bijection. First for injectivity, suppose $\nu, \mu \in \text{Cone}(G, F)$ such that $\phi_G(\nu) = \phi_G(\mu)$. Then for all $a \in A$, $\text{ev}_a \nu = \text{ev}_a \mu$ by bijectivity of $m_{a, G a}$. Then,

$\text{ev}_a \nu_j = \text{ev}_a \mu_j$ which are the components of ν_j and μ_j at a , thus $\nu_j = \mu_j$. But these are the components of ν and μ at j . Thus $\nu = \mu$. For surjectivity, suppose $\delta \in \mathbf{C}^A(G, \lim F)$. By bijectivity of $m_{a, Ga}$, we can map each component of δ to a natural transformation $\delta_a^*: Ga \Rightarrow \text{ev}_a F$ whose components are $\delta_{a,j}^*: Ga \rightarrow \text{ev}_a Fj$, but one can form a natural transformation $\delta_j^*: G \rightarrow Fj$ from each δ_a^* by taking the j -component of each of the δ_a^* . To verify that δ_j^* is a natural transformation, see that diagram

$$\begin{array}{ccc}
 Ga_1 & \xrightarrow{Gf} & Ga_2 \\
 \delta_{a_1} \downarrow & & \downarrow \delta_{a_2} \\
 \lim_{a_1} F & \xrightarrow{\lim Ff} & \lim_{a_2} F \\
 \lambda_{a_1, j} \downarrow & & \downarrow \lambda_{a_2, j} \\
 \text{ev}_{a_1} Fj & \xrightarrow{F_j f} & \text{ev}_{a_2} Fj
 \end{array}$$

commutes since the top square is the commutative diagram for δ and the bottom square is the commutative diagram for defining $\lim Ff$. Furthermore $\delta_{a,j}^* = \lambda_{a,j} \cdot \delta_a$ since m_a is the natural isomorphism induced by the limit cone λ_a . We can make each δ_j^* a component of a cone $\delta^*: G \Rightarrow F$. The fact that δ^* is a natural transformation follows from the fact that δ_a^* is a natural transformation. Furthermore, $\phi_G(\delta^*) = \{m_{a, Ga}(\text{ev}_a \delta^*) \mid a \in A\} = \{m_{a, Ga}(\delta_a^*) \mid a \in A\} = \{\delta_a \mid a \in A\} = \delta$. Thus ϕ_G is surjective, making ϕ_G a bijection, and by extension ϕ is an isomorphism. To confirm naturality of ϕ consider the following diagram for natural transformation $\epsilon: G \Rightarrow H$ in \mathbf{C}^A :

$$\begin{array}{ccc}
 \text{Cone}(G, F) & \xrightarrow{\Delta \epsilon \cdot -} & \text{Cone}(H, F) \\
 \phi_G \downarrow & & \downarrow \phi_H \\
 \mathbf{C}^A(G, \lim F) & \xrightarrow{\epsilon \cdot -} & \mathbf{C}^A(H, \lim F)
 \end{array}$$

where $\Delta \epsilon$ is the natural transformation whose components are ϵ for each $j \in J$. Take $\alpha \in \text{Cone}(G, F)$, we get the natural transformations $\epsilon \cdot \phi_G(\alpha)$ and $\phi_H(\Delta \epsilon \cdot \alpha)$. To show that they are equal notice that $\phi_H(\Delta \epsilon \cdot \alpha) = \{m_{a, Ha}(\text{ev}_a(\Delta \epsilon \cdot \alpha)) \mid a \in A\} = \{m_{a, Ha}(\Delta \epsilon_{-, a} \cdot \text{ev}_a \alpha) \mid a \in A\}$. Every component of $\Delta \epsilon_{-, a}$ is simply the component of ϵ at a so $\phi_H(\Delta \epsilon \cdot \alpha) = \{\epsilon_a \cdot m_{a, Ga}(\text{ev}_a \alpha) \mid a \in A\} = \{\epsilon_a \cdot \phi_G(\alpha)_a \mid a \in A\} = \epsilon \cdot \phi_G(\alpha)$. Thus ϕ is a natural transformation confirming that $\text{Cone}(-, F) \cong \mathbf{C}^A(-, \lim F)$ and $\lim F$ is the limit of F . Since the objects of $\lim F$ are the limits of $\text{ev}_a F$ for all a , thus the limits of $\text{ev}_a F$ define an action on objects of $\lim F$. The corresponding result for colimits follow from duality. \square

3.4 The representable nature of limits and colimits

EXERCISE 3.4.i. Show that the isomorphism (3.4.1) is natural.

PROOF. Take an object X fixed in a category \mathbf{C} and a fixed diagram J . Then the isomorphism $\lim_J \mathbf{C}(X, F-) \cong \text{Cone}(X, F)$ defines a morphism $\alpha_X: \lim_J \mathbf{C}(X, F) \rightarrow \text{Cone}(X, F)$ for each fixed X . With X fixed, the legs of the cone over F with summit X are the tuples of morphisms $(\lambda_j: X \rightarrow Fj)_{j \in J}$.

Now, taking a morphism $f: X \rightarrow Y$ in \mathbf{C} , there is a morphism $\alpha_Y: \lim_J \mathbf{C}(Y, F) \rightarrow \text{Cone}(Y, F)$ and morphisms $Ff: \lim_J \mathbf{C}(Y, F) \rightarrow \lim_J \mathbf{C}(X, F)$, and $\lambda_j: \text{Cone}(Y, F) \rightarrow \text{Cone}(X, F)$, such that $f\lambda_j\alpha_Y = \alpha_X Ff$. The corresponding naturality square commutes, and thus the isomorphism in 3.4.1 is natural.

EXERCISE 3.4.ii. Explain in your own words why the Yoneda embedding $\mathbf{C} \hookrightarrow \text{Set}^{\mathbf{C}^{\text{op}}}$ preserves and reflects but does not create limits.

Recall that the Yoneda embedding of a category \mathbf{C} takes each object to the presheaf which it represents and maps to natural transformations between these presheaves. Explicitly, an object c becomes the hom-functor $\mathbf{C}(-, c)$, and a map f becomes the natural transformation of post-composition with f . The Yoneda lemma states that this functor is fully faithful, and thus \mathbf{C} is realised as a full subcategory of $\text{Set}^{\mathbf{C}^{\text{op}}}$. Recall that this means $\text{Set}^{\mathbf{C}^{\text{op}}}$ may contain objects not in \mathbf{C} , but if the domain and codomain of a morphism are present in both categories then the morphism must be as well. For the sake of brevity we will treat \mathbf{C} as being part of $\text{Set}^{\mathbf{C}^{\text{op}}}$ and ignore the renaming implicit in the isomorphism. Correspondingly, a functor $F: J \rightarrow \mathbf{C}$ is also a functor $F: J \rightarrow \text{Set}^{\mathbf{C}^{\text{op}}}$.

This makes it immediately clear why the Yoneda embedding reflects limits. Given a cone over the diagram $F: J \rightarrow \text{Set}^{\mathbf{C}^{\text{op}}}$ with an apex c , first, this cone will exist in \mathbf{C} if and only if c and Fj where $j \in \text{ob } J$ are objects in \mathbf{C} . Second, if this is a limit cone in $\text{Set}^{\mathbf{C}^{\text{op}}}$, then there is a unique map from any other cone over F subject to naturality conditions. If the apex of this cone is in \mathbf{C} , then so must be the unique map by the condition that the \mathbf{C} is a full subcategory. Thus K will still be a limit cone considering only the objects and morphisms in \mathbf{C} .

Now, suppose that c is the limit of a functor $F: J \rightarrow \mathbf{C}$

However, given an arbitrary object c in $\text{Set}^{\mathbf{C}^{\text{op}}}$ there is no guarantee that there is an object in \mathbf{C} isomorphic to c . Thus if c happens to be the apex of a limit cone, it is impossible for that cone to have a limit in \mathbf{C} even if the base of that cone is entirely in \mathbf{C} .

EXERCISE 3.4.iii. Generalize Proposition 3.3.8 to show that for any $F: \mathbf{C} \rightarrow \text{Set}$, the projection functor $\Pi: \int F \rightarrow \mathbf{C}$:

1. strictly creates all limits that \mathbf{C} admits and that F preserves, and
2. strictly creates all connected colimits that \mathbf{C} admits.

Consider an ordered pair (K, x) where $K : J \rightarrow \mathbf{C}$ and $x : 1 \Rightarrow FK$. Here $1 = \{0\}$ is a singleton set, or the corresponding constant functor from J to \mathbf{Set} , and we identify $x_i : 1 \rightarrow FK_i$ with $x_i(0) \in FK_i$. This pair gives a diagram $(K, x) : J \rightarrow \int F$. For each morphism $g : i \rightarrow j$ in J the morphism $(K, x)g : (K_i, x_i) \rightarrow (K_j, x_j)$ is given by $Kg : K_i \rightarrow K_j$. This is a morphism in $\int F$ because the natural transformation $x : 1 \Rightarrow FK$ tells us that $FKg(x_i) = x_j$.

Now, all diagrams $L : J \rightarrow \int F$ are of this form. Indeed, let $K = \Pi L$. Then for every $i \in \text{ob } J$ we have that $L_i = (K_i, x_i)$ for some $x_i \in FK_i$ and for every $g : i \rightarrow j$, $Lg : (K_i, x_i) \rightarrow (K_j, x_j)$ is given by $Kg : K_i \rightarrow K_j$ such that $FK(x_i) = x_j$. But, this precisely gives a natural transformation $x : 1 \Rightarrow FK$ as described above.

Now, for part (1) say that $K : J \rightarrow \mathbf{C}$ has a limit cone $\lambda : \lim K \Rightarrow K$ and that F preserves this limit. That is, $F\lambda : F \lim K \Rightarrow FK$ is also a limit cone. Then the natural transformation $x : 1 \Rightarrow FK$ must uniquely factor through $F\lambda$. That is, there is a unique $\hat{x} : 1 \rightarrow F \lim K$ such that $F\lambda \circ \hat{x} = x$. We conflate the symbol \hat{x} with $\hat{x}(0) \in F \lim K$. By construction, $F\lambda_i(\hat{x}) = x_i \in FK_i$. This gives us a cone $\hat{\lambda} : (\lim K, \hat{x}) \Rightarrow (K, x)$. Furthermore, $\Pi \hat{\lambda} = \lambda$.

We must now show that $\hat{\lambda}$ is the only lift of λ and that $\hat{\lambda}$ is a limit cone. So, let $\mu : (c, z) \Rightarrow (K, x)$ be a natural transformation for which $(c, z) \in \text{ob } \int F$ (that is, $c \in \text{ob } \mathbf{C}$ and $z \in Fc$) and $\Pi \mu = \lambda$. Then $c = \Pi(c, z) = \lim K$ so that $z \in F \lim K$ and $F\lambda_i(z) = x_i$ for each $i \in \text{ob } J$. Identifying z with the constant function $z : 1 \rightarrow F \lim K$ we have that $F\lambda \circ z = x$. But, \hat{x} was uniquely defined by this property, so that $z = \hat{x}$. Comparing now with $\hat{\lambda}$, we have that $\mu = \hat{\lambda}$ as required. This proves that $\hat{\lambda}$ is the unique lift of λ .

Now, we must see that $\hat{\lambda} : (\lim K, \hat{x}) \Rightarrow (K, x)$ is a limit cone. Let $\mu : (c, z) \Rightarrow (K, x)$ be another cone. (Here, $c \in \text{ob } \mathbf{C}$, $z \in Fc$ and μ are not the same c , z and μ as in the previous paragraph.) We must prove that μ factors uniquely through $\hat{\lambda}$. Since $\Pi \mu : c \Rightarrow K$, there is a unique $f : c \rightarrow \lim K$ in \mathbf{C} such that $\lambda f = \Pi \mu$. Also, for every $i \in \text{ob } J$, $x_i = F\Pi \mu_i(z) = F\lambda_i f(z)$. Just as in the previous paragraph, we have that $F\lambda \circ f(z) = x$ so that $f(z)$ satisfies the defining property of \hat{x} . Thus, $f(z) = \hat{x}$ and $f : c \rightarrow \lim K$ determines a morphism $\hat{f} : (c, z) \rightarrow (\lim K, \hat{x})$ in $\int F$. This morphism is the unique morphism such that $\hat{\lambda} \hat{f} = \mu$, showing that $\hat{\lambda} : (\lim K, \hat{x}) \Rightarrow (K, x)$ is a limit cone.

For the second part, say that J is a small connected category (which is in particular nonempty) and that $(K, x) : J \rightarrow \int F$ is a diagram such that $K : J \rightarrow \mathbf{C}$ has a colimit cone $\lambda : K \Rightarrow \text{colim } K$. We start by building a lift $\hat{\lambda} : (K, x) \Rightarrow (\text{colim } K, \hat{x})$. Since $x : 1 \Rightarrow FK$ is a natural transformation, for any $g : i \rightarrow j$ in J we have that $x_j = FKg(x_i)$. Using that $\lambda : K \Rightarrow \text{colim } K$ is a natural transformation and F is a functor, we find that

$$F\lambda_i(x_i) = F(\lambda_j K g)(x_i) = F\lambda_j FK g(x_i) = F\lambda_j(x_j).$$

Since J is connected, this implies that $F\lambda_i(x_i) = F\lambda_j(x_j)$ for arbitrary objects $i, j \in \text{ob } J$. Since $J \neq \emptyset$, we may then define $\hat{x} \in F \text{colim } J$ by $\hat{x} = \lambda_i(x_i)$ for an arbitrary choice of

$i \in \text{ob } \mathbf{J}$ and the definition is independent of that choice. This gives a cone $\hat{\lambda} : (K, x) \Rightarrow (\text{colim } K, \hat{x})$ under (K, x) such that $\Pi\hat{\lambda} = \lambda$.

We now show that $\hat{\lambda}$ is the unique lift of λ . Let $\mu : (K, x) \Rightarrow (c, z)$ be another cone under (K, x) such that $\Pi\mu = \lambda$. Then $c = \text{colim } K$ since $\Pi\mu = \lambda$. Furthermore, for any $i \in \text{ob } \mathbf{J}$, $z = F\lambda_i(x_i) = \hat{x}$. So, μ is identical with $\hat{\lambda}$.

Finally, we must show that $\hat{\lambda} : (K, x) \Rightarrow (\text{colim } K, \hat{x})$ is a colimit cone. Let $\mu : (K, x) \Rightarrow (c, z)$ be another cone under (K, x) . Then $\Pi\mu : K \Rightarrow c$ is a cone under K in \mathbf{C} , so that there is a unique morphism $f : \text{colim } K \rightarrow c$ in \mathbf{C} such that $\Pi\mu = f\lambda$. Further, for any $i \in \text{ob } \mathbf{J}$, we have that

$$Ff(\hat{x}) = FfF\lambda_i(x_i) = F(f\lambda_i)(x_i) = F\Pi\mu_i(x_i) = z.$$

So, the f that we uniquely determined gives a morphism $\hat{f} : (\text{colim } K, \hat{x}) \rightarrow (c, z)$, the unique morphism such that $\mu = \hat{f}\hat{\lambda}$. This proves that $\hat{\lambda} : (K, x) \Rightarrow (\text{colim } K, \hat{x})$ is a colimit cone.

EXAMPLE 3.1.10. The product of a pair of spaces X and Y is a space $X \times Y$ equipped with continuous projection functions

$$X \xleftarrow{\pi_X} X \times Y \xrightarrow{\pi_Y} Y$$

satisfying the universal property: for any other space A with continuous maps $f : A \rightarrow X$ and $g : A \rightarrow Y$, there is a unique continuous function $h : A \rightarrow X \times Y$ so that the following diagram commutes:

$$\begin{array}{ccc} & A & \\ f \swarrow & \downarrow \exists! h & \searrow g \\ X & X \times Y & Y \\ \pi_X \swarrow & & \searrow \pi_Y \end{array}$$

LEMMA 3.4.16. In any category with a terminal object 1 , the pullback diagram

$$\begin{array}{ccc} A \times B & \xrightarrow{\pi_B} & B \\ \pi_A \downarrow & \lrcorner & \downarrow ! \\ A & \xrightarrow{\quad} & 1 \\ & & \downarrow ! \end{array}$$

defines the product of $A \times B$ of A and B .

EXERCISE 3.4.iv. Prove Lemma 3.4.16.

PROOF. As is suggested in the text below the lemma, "It is straightforward to use the universal property of the displayed pullback to verify that the diagram $A \xleftarrow{\pi_A} A \times B \xrightarrow{\pi_B} B$ has the universal property that defines a product." We will argue in this manner.

Consider an object D having continuous morphisms to A and B :

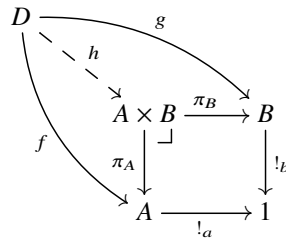

If this diagram commutes, then h exists and is unique. To see that it commutes, examine the following diagram, where $k: D \rightarrow 1$ is the unique morphism from D to 1 (since 1 is a final object).

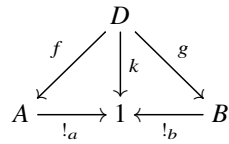

We know that this must commute, since k is unique. So we have that $!_a f = k = !_b g$. Since we have that $!_a f = !_b g$, the pullback above commutes, and h exists and is unique. Then, forgetting about the $!$ morphisms, we have precisely the definition of the product from Example 3.1.10. \square

3.5 Complete and cocomplete categories

EXERCISE 3.5.i. Let G be regarded as a 1-object category BG . Describe the colimit of a diagram $BG \rightarrow \text{Set}$ in group-theoretic terms, as was done for the limit in Example 3.2.12.

Proof. For a diagram $D : BG \rightarrow \text{Set}$, note that

$$\text{colim } D = \frac{\coprod_{k \in BG} Dk}{\sim}$$

where \sim is the smallest equivalence relation on the coproduct such that for every $g : i \rightarrow j \in BG$ and $n \in Di$, $\iota_{Dj} Dg(n) \sim \iota_{Di} n$. So, for example, the following diagram illustrates a part of the diagram D :

$$\begin{array}{ccc} Di & \xrightarrow{g} & Dj \\ \searrow \iota_{Di} & & \swarrow \iota_{Dj} \\ & \coprod_{k \in BG} Dk & \end{array}$$

But in this case, the only object in our diagram is a set X , and the morphisms in our diagram are simply the left actions of elements of G applied to a set X . The following specializes the above diagram to this specific case:

$$\begin{array}{ccc} X & \xrightarrow{g} & X \\ \searrow \iota_X & & \swarrow \iota_X \\ & X & \end{array}$$

Of course, the inclusion map $\iota_X : X \rightarrow X$ is simply the identity, so we need to have that $g(x) \sim x$ in $\text{colim } D$. This means each equivalence class must consist of an element $x \in X$, along with $g(x)$ for every $g \in G$. In other words, $[x] = \{x, g(x) | g \in G\}$, also known as the orbit of x . So the set of all equivalence classes (that is, the colimit we are looking for) is simply the orbit space (that is, the set of all orbits) of the action of G on X .

EXERCISE 3.5.ii. Prove that the colimit of any small functor $F : \mathbf{C} \rightarrow \text{Set}$ is isomorphic to the set $\pi_0(\int F)$ of connected components of the category of elements of F . What is the colimit cone?

PROOF. Since F is a small functor by assumption, we can construct the colimit of F in the usual way. Define $\iota_c : Fc \rightarrow \coprod_{c \in \text{ob } \mathbf{C}} Fc / \sim$, where \sim is the smallest equivalence relation such that for all $f : c \rightarrow c'$ in \mathbf{C} and x in Fc , we have $\iota_c(x) \sim \iota_{c'} Ff(x)$. Recall that

the objects of $\int F$ are ordered pairs (c, x) , where c is in \mathbf{C} and x is in Fc , and morphisms are defined as maps $f: c \rightarrow c'$ in \mathbf{C} such that $Ff(x) = x'$. If we restrict ourselves to the set of connected components of $\int F$, we get $\pi_0(\int F)$.

First note that two elements of in the colimit of F are related if and only if $\iota_c(x) \sim \iota_{c'}$ for all $f: c \rightarrow c'$ in \mathbf{C} . Next two objects A and B in $\text{ob } \int F$ are related if and only if there is zig zag of morphisms between them. Now observe the that between any two objects (Fj, x) and (Fk, x') there is a map $f: x \rightarrow x'$ such that $(Fj, x) \xrightarrow{f} (Fk, x')$. This diagram tells us that two objects in $\pi_0(\int F)$ are connected under by Ff . This relationships puts the generators of each equivalence relation in one-to-one correspondence via the map $[(c, x)] \mapsto [\iota_c(x)]$. Since the generators are in bijection with each other the equivalence relations generated by them are also in bijection. The colimit cone is a natural transformation from F to $\text{colim } F$. Each leg of the cone is a homomorphism that preserves connected components. \square

EXERCISE 3.5.iii. Prove that the category DirGraph of directed graphs is complete and cocomplete and explain how to construct its limits and colimits.

PROOF. We will show that DirGraph has products, equalizers, co-products and co-equalizers. We begin by defining an element of DirGraph . We say that a graph G consists of a vertex set V , an edge set E and two function $s, t: E \rightarrow V$, where s sends an edge to its source and t sends an edge to its target. In this setting, we say that a graph homomorphism from $G = (V, E, s, t) \rightarrow H = (W, F, s', t')$ is a pair of functions $f_{\text{vert}}: V \rightarrow W$ and $f_{\text{edge}}: E \rightarrow F$ such that $f_{\text{vert}}s = s'f_{\text{edge}}$ and $f_{\text{vert}}t = t'f_{\text{edge}}$.

Products: We will show that for a collection I of graphs, the product $\prod_{i \in I} G_i = (V_i, E_i, s_i, t_i)$ is defined as the graph where the vertex set is the Cartesian product of the V_i 's, the edge set is the Cartesian product of the E_i 's, the source function is defined by $s(e) = (s_i(e_i))_{i \in I}$ and the target function is defined by $t(e) = (t_i(e_i))_{i \in I}$. We see that there are obvious projection maps π_i taking a product graph to the i^{th} component and we now must show it's universality.

Suppose there is another graph H , with morphisms σ_i to every G_i . If these morphisms factor through $\prod_{i \in I} G_i$, then the morphism $\phi: H \rightarrow \prod_{i \in I} G_i$ must be composed of ϕ_{vert} and ϕ_{edge} where $\phi_{\text{vert}}(h) = (\sigma_{i_{\text{vert}}}(h))_{i \in I}$ and $\phi_{\text{edge}}(h) = (\sigma_{i_{\text{edge}}}(h))_{i \in I}$. We must show that this a graph homomorphism, mainly that $s\phi_{\text{edge}} = \phi_{\text{vert}}s'$. For an edge w in $E(H)$, we see that $s\phi_{\text{edge}}(w) = s((\sigma_{i_{\text{edge}}}(h))_{i \in I}) = (s_i((\sigma_{i_{\text{edge}}}(h))_{i \in I}))_{i \in I}$. Because σ_i is a graph homomorphism, we have that this is equal to $(\sigma_{i_{\text{vert}}}(s'(e)))_{i \in I}$ which equals $\phi_{\text{vert}}s'(e)$. So we have the equality we desire, and by a similar method we have $t\phi_{\text{edge}} = \phi_{\text{vert}}t'$ and we have the graph homomorphism we desire. So our definition of the product is universal, and we have products in DirGraph .

Equalizers: Suppose we have graphs A and B and parallel morphisms f and g . We will show that the equalizer of this diagram is E , the subgraph of A which includes all edges e where $s'f_{\text{edge}}(e) = s'g_{\text{edge}}(e)$ and $t'f_{\text{edge}}(e) = t'g_{\text{edge}}(e)$ and all vertices v where $f_{\text{vert}}(v) = g_{\text{vert}}(v)$. The inclusion mapping $\iota: E \rightarrow A$ clearly makes this a cone over our diagram and also $f\iota = g\iota$. We now show the universality of E .

Suppose we have a C that has a map k to A such that $fk = gk$. Since E is a subgraph of A , if this map factors through E , the map from C to E , must take c to $k(c)$. We see that if $fk = gk$, we have that $f_{vert}(k(c)) = g_{vert}(k(c))$ for all vertices $c \in C$ and that $s'f_{edge}(k(d)) = s'g_{edge}(k(d))$ and $t'f_{edge}(k(d)) = t'g_{edge}(k(d))$ for all edges d in C . So we see that $k(C) \subset E$ and so this construction is valid. Because of this, we see that E is universal and so we have equalizers.

We have products and equalizers and therefore we have all limits and DirGraph is complete.

Co-products: We define the vertex set of the coproduct $\coprod_{i \in I} G_i$ as the disjoint union of the vertex sets and the edge set to be the disjoint union of the edge sets. Now $s((e, i) = s_i(e)$ and $t((e, i) = t_i(e)$. Note that we have inclusion maps ι_i and so this is a cone under our diagram, now we show that this cone is universal.

Suppose we have a graph $H = (F, W, s', t')$ with morphisms σ_i from each G_i to H . Since for each G_i , $\iota_i(a) = (a, i)$, and if we want to find a $k: \coprod_{i \in I} G_i \rightarrow H$ such that $\sigma_i = k\iota_i$, we must have that $k_{vert}((a, i)) = \sigma_{i_{vert}}(a)$ for all vertices $a \in G_i$ and that $k_{edge}((e, i)) = \sigma_{i_{edge}}(e)$. We now see that this is indeed a graph homomorphism. To do this, we must show that $s'k_{vert} = k_{edges}$. Consider an edge (e, i) in the coproduct. $k_{vert}s((e, i)) = k_{vert}(s_i(e)) = \sigma_{i_{vert}}(s_i(e))$. Also, $s'k_{edge}((e, i)) = s'\sigma_{i_{edge}}(e)$. But by our definition of graph homomorphism, we see that $\sigma_{i_{vert}}(s_i(e)) = s'\sigma_{i_{edge}}(e)$ because σ_i is a graph homomorphism, so we have that $s'k_{vert} = k_{edges}$ and we can easily show $t'k_{vert} = k_{edges}t$ similarly. So k is a graph homomorphism and therefore our definition of the coproduct is universal. Therefore DirGraph has coproducts.

Co-equalizers: Now, consider two parallel morphisms $f, g: G \rightarrow H$. We construct a graph $\text{coeq}(f, g) = (\text{coeq}(f_{vert}, g_{vert}), \text{coeq}(f_{edge}, g_{edge}), s_{eq}, t_{eq})$. We see what s_{eq} is through the following diagram.

$$\begin{array}{ccccc}
 E & \begin{array}{c} \xrightarrow{f_{edge}} \\ \xrightarrow{g_{edge}} \end{array} & F & \xrightarrow{s'} & W & \xrightarrow{\quad} & \text{coeq}(f_{vert}, g_{vert}) \\
 & & & \searrow & & \nearrow & \\
 & & & & & & \text{coeq}(f_{edge}, g_{edge})
 \end{array}$$

(Note: A dashed arrow labeled s_{eq} points from $\text{coeq}(f_{edge}, g_{edge})$ to $\text{coeq}(f_{vert}, g_{vert})$.)

We must now show the existence of s_{eq} . First, we see that since $s'f_{edge} = f_{vert}s$ and $s'g_{edge} = g_{vert}s$, we have a morphism k where $kf_{edge} = kg_{edge}$, namely qs' , where q is the map from $W \rightarrow \text{coeq}(f_{vert}, g_{vert})$. So this morphism factors uniquely through $\text{coeq}(f_{edge}, g_{edge})$ and s_{eq} is the unique morphism from $\text{coeq}(f_{edge}, g_{edge})$ to $\text{coeq}(f_{vert}, g_{vert})$ that allow for this factorization. A similar process gives us a formula for t_{eq} .

To show that this construction of $\text{coeq}(f, g)$ is universal, we see that for any graph $K = (X, I, s_*, t_*)$, with morphism h from $H \rightarrow K$, that h factors uniquely through the coequalizer because h_{vert} and h_{edge} uniquely factor through the coequalizer of the vertex maps and edge maps respectively. So $\text{coeq}(f, g)$ is indeed universal and we have coequalizers.

So DirGraph has coproducts and coequalizers and is therefore cocomplete.

Now, we construct limits and colimits in DirGraph , in particular for a diagram $F: J \rightarrow \text{DirGraph}$. First, we note that there are functors $V, E: \text{DirGraph} \rightarrow \text{Set}$ that takes a graph

to its vertex and edge sets respectively. So we construct $\lim F$ as $(\lim VF, \lim EF, s, t)$. We define s and t in the following manner. We know that we have maps from $\lim EF \rightarrow EFj$ for all $j \in J$ and that we have a map $s_j : EFj \rightarrow VFj$. So we have collection of mappings from $\lim EF$ to VFj and so we have a map from $\lim EF \rightarrow \lim VF$ that these maps uniquely factor through. This map is our s , and t is similarly constructed. We define $\text{colim } F = (\text{colim } VF, \text{colim } EF, s', t')$, where we define s' as follows. We know that we have maps $s_j : EFj \rightarrow VFj$ and maps from $VFj \rightarrow \text{colim } F$. So the compositions of these maps are maps from $EFj \rightarrow \text{colim } VF$ for all $j \in J$. So these maps factor uniquely through some map from $\text{colim } EF \rightarrow \text{colim } VF$ and s' is exactly this morphism. We define t' in a similar manner. \square

EXERCISE 3.5.iv. For a small category J , define a functor $i_0 : J \rightarrow J \times 2$ so that the pushout

$$\begin{array}{ccc} J & \xrightarrow{!} & \mathbb{1} \\ i_0 \downarrow & & \downarrow s \\ J \times 2 & \longrightarrow & J^{\natural} \end{array}$$

in Cat defines the cone over J , with the functor $s : \mathbb{1} \rightarrow J^{\natural}$ picking out the summit object. Remark 3.1.8 gives an informal description of this category, which is used to index the diagram formed by a cone over a diagram of shape J .

PROOF. The functor i_0 can be defined by taking objects j to the tuple $(j, 0)$ and morphisms f to the morphism $f \times 1_0$. to show that the above diagram commutes Call the bottom functor π and we will define π as follows:

1. π maps object $(j, 0)$ to the summit object in J^{\natural} which we will denote as s^* .
2. π maps object $(j, 1)$ to j
3. π maps morphism $f \times 1_0$ to 1_{s^*}
4. π maps morphism $f \times 1_1$ to f
5. π maps morphism $f \times \phi$ where ϕ is the unique morphism in 2 from 0 to 1 to the leg of the cone in J^{\natural} from s^* to $\text{cod } f$ which we will denote as $c_{\text{cod } f}$

To ensure that π is a functor, take an identity morphism $1_j \times 1_i$. π will map $1_j \times 1_i$ to either 1_{s^*} or 1_j , thus π preserves identities. Now take morphisms $f \times m_0$ and $g \times m_1$ such that $g \cdot f \times m_1 \cdot m_0$ make sense. $m_1 \cdot m_0$ determines what π maps $g \cdot f \times m_1 \cdot m_0$ to. If $m_1 \cdot m_0 = 1_0$, then $m_1 = m_0 = 1_0$, then $f \times m_0, g \times m_1$ and $g \cdot f \times m_1 \cdot m_0$ get mapped to 1_{s^*} . If $m_1 \cdot m_0 = 1_1$, then $m_1 = m_0 = 1_1$, then $f \times m_0, g \times m_1$ and $g \cdot f \times m_1 \cdot m_0$ get mapped to $f, g,$ and $g \cdot f$ respectively. If $m_1 \cdot m_0 = \phi$, then either $m_0 = \phi$ and $m_1 = 1_1$ or $m_0 = 1_0$ and $m_1 = \phi$, thus either $\pi(f \times m_0) = c_{\text{cod } f}$ and $\pi(g \times m_1) = g$ or $\pi(f \times m_0) = 1_{s^*}$ and $\pi(g \times m_1) = c_{\text{cod } g}$. Also, π maps $g \cdot f \times m_1 \cdot m_0$ to $c_{\text{cod } g}$. For the first case, the fact that $g \cdot c_{\text{cod } f} = c_{\text{cod } g}$ follows from the fact that $c_{\text{cod } f}$ and $c_{\text{cod } g}$ are legs of a cone under s^* . The second case follows trivially. Thus, π preserves composition. Therefore π is a functor. Let $j \in \text{ob } J$ and $f \in \text{mor } J$, then $\pi \cdot i_0 j = s^* = s \cdot !j$ and $\pi \cdot i_0 f = 1_{s^*} = s \cdot !f$. Thus the above diagram commutes. Now to show that J^{\natural} is the colimit of the diagram, Let C be a small category with functors $p_0 : J \times 2 \rightarrow C$ and $p_1 : \mathbb{1} \rightarrow C$ such that $p_0 \cdot i_0 = p_1 \cdot !$. Define a functor $v : J^{\natural} \rightarrow C$ as follows

1. ν maps s^* to object $p_0(j, 0)$ for some $j \in \text{ob } \mathbf{J}$
2. ν maps non-summit object j in $\mathbf{J}^{\triangleleft}$ to $p_0(j, 1)$
3. ν maps 1_{s^*} to $p_0(f \times 1_0)$ for some $f \in \text{mor } \mathbf{J}$
4. ν maps morphism f between non-summit objects to $p_0(f \times 1_1)$
5. ν maps each leg c_j to $p_0(1_j \times \phi)$

ν is well-defined since $p_0 \cdot i_0 = p_1 \cdot !$. To verify that ν is a functor, note that $p_0(f \times 1_0) = 1_{p_0(j,0)}$ by the previously stated equation and since $\mathbb{1}$ only has the identity morphism on 0. Also, $p_0(1_j \times 1_1)$ is an identity morphism by functoriality of p_0 . Thus ν preserves identities. ν preserves composition of morphism since p_0 is a functor. So we have that ν is a functor. The fact that $p_1 = \nu \cdot s$ follows from that fact that $p_0(j, 0) = p_1 \cdot 0$. To show $p_0 = \nu \cdot \pi$, note that we only need to show that $p_0(1_j \times \phi) = p_0(h \times \phi)$ whenever $\text{cod } h = j$ since every other case is covered in the definition of ν . By functoriality, we have that $p_0(h \times \phi) = p_0(1_j \times \phi) \cdot p_0(h \times 1_0) = p_0(1_j \times \phi)$. Uniqueness of ν follows from construction and from the equation $p_0 \cdot i_0 = p_1 \cdot !$. Therefore, $\mathbf{J}^{\triangleleft}$ is the colimit of the above diagram. \square

EXERCISE 3.5.v. Describe the limits and colimits in the poset of natural numbers with the order relation $k \leq n$ if and only if k divides n .

PROOF. Recall that when considering a poset as a category, a morphism $f: c \rightarrow d$ exists if and only if $c \leq d$, and that f is unique for the given domain and codomain. In this case, $c \leq d$ means c divides d . The limit of the diagram must be able to divide everything in the diagram. Because of the structure of the morphisms, commutativity and uniqueness are not issues. We need to find an element that divides everything in the diagram, but also is universal in the sense that anything else that divides everything in the diagram also divides our limit. Thus, we choose the greatest common divisor of the objects in the diagram. The greatest common divisor is divisible by any smaller divisor, and thus will be our limit.

Similarly, for colimits we need to find an object that is divided by every object in the diagram. It also must divide any natural number that is divided by everything in the diagram. Thus, we must choose our colimit as the least common multiple, which divides any other multiple.

Now we consider the empty diagram as a special case, as the concepts of GCD and LCM would not apply. In the case of the empty diagram, the limit would be 0, which can be divided by every other natural number, and thus is a terminal object. The colimit would be 1, as it divides everything, and is our initial object. \square

EXERCISE 3.5.vi. Define a contravariant functor $\text{Fin}_{\text{mono}}^{\text{op}} \rightarrow \text{Top}$ from the category of finite sets and injections to the category of topological spaces that sends a set with n elements to the space $\text{PConf}_n(X)$ constructed in Example 3.5.4. Explain why the functor does not induce a similar functor sending an n -element set to the space $\text{Conf}_n(X)$.

PROOF. Recall that

$$\text{PConf}_n(X) = \{(x_1, \dots, x_n) \mid x_i \neq x_j \forall i \neq j\}.$$

For simplicity we will define $F: \text{Fin}_{\text{mono}}^{\text{op}} \rightarrow \text{Top}$ on finite sets of the form $\{0, \dots, n-1\}$ and then extend F to arbitrary finite sets. Define F on the objects by the map $\{0, \dots, n-1\} \mapsto \text{PConf}_n(X)$ and on morphisms as $(x_0, \dots, x_{n-1}) \mapsto (x_{f(0)}, \dots, x_{f(n-1)})$. Note that this functor is contravariant as we have f in the subscripts not f^{-1} . We also needed that f was injective else we could land on the “fat diagonal.” For example if f has sent every element to 0 we would be on the actual diagonal, not even the fat one.

To extend this map to any finite set we first note that every finite set A with n elements is pretty much the same as the set $\{0, \dots, n-1\}$, since we can always find a bijection between them, so the extension should not be too bad. For any finite set A with n elements we can fix⁷ a bijection $\phi_A: A \rightarrow \{0, \dots, n-1\}$. This gives a commutative diagram for finite sets A and B of sizes m and n respectively and an injective map f between them.

$$\begin{array}{ccc} A & \xrightarrow{f} & B \\ \phi_A \downarrow & & \downarrow \phi_B \\ \{0, \dots, m-1\} & \xrightarrow{\phi_B f \phi_A^{-1}} & \{0, \dots, n-1\} \end{array}$$

Now we can extend $F: \text{Fin}_{\text{mono}}^{\text{op}} \rightarrow \text{Top}$ on morphisms as $Ff := F(\phi_B f \phi_A)^{-1}$, where F sends both ϕ_A and ϕ_B^{-1} to the identity map in $\text{Conf}_n(X)$. This is equivalent to $(x_1, \dots, x_n) \mapsto (x_{f(1)}, \dots, x_{f(n)})$, while leaving the action on objects the same.

If we try and induce a similar functor, but allowed for permutation we could have for a fixed injective map f that takes order tuples in the same equivalence class to tuples in different equivalence classes. Consider the ordered triples (x_0, x_1, x_2) and (x_1, x_2, x_0) and the map $g: \{0, 1\} \rightarrow \{1, 2, 3\}$ with $g(0) = 1$ and $g(1) = 2$. If we apply the functor we defined earlier we have $(x_0, x_1, x_2) \mapsto (x_0, x_1)$ and $(x_1, x_2, x_0) \mapsto (x_1, x_2)$. Even though (x_0, x_1, x_2) and (x_1, x_2, x_0) were in the same equivalence class (x_0, x_1) and (x_1, x_2) are not. □

EXERCISE 3.5.vii. Following Grothendieck, define a **fiber space** $p: E \rightarrow B$ to be a morphism in Top . A map of fiber spaces is a commutative square. Thus the category of fiber spaces is isomorphic to the diagram category Top^2 . We are also interested in the non-full subcategory $\text{Top}/B \subset \text{Top}^2$ of fiber spaces over B and maps whose codomain component is the identity. Prove the following:

(i) A map

$$\begin{array}{ccc} E' & \xrightarrow{g} & E \\ \downarrow p' & & \downarrow p \\ B' & \xrightarrow{f} & B \end{array}$$

⁷Notice to do we do need to invoke the Axiom of Choice in a larger universe as the collection of singletons is a proper class, so we are choosing a proper class worth of bijections.

of fiber spaces induces a canonical map from the fiber of a point $b \in B'$ to the fiber over its image $f(b) \in B$.

PROOF. The fiber of b is a subset of E' , so we may consider its image under g . Given a point e in this set we have that $p'(e) = b$ and $pg(e) = fp'(e)$ by assumption, and thus $pg(e) = f(b)$. This means that $g(e)$ is in the fiber of $f(b)$ and thus the restriction of g to the fiber of b lands in the fiber of $f(b)$. \square

(ii) The fiber of a product of fiber spaces is the product of the fibers.

PROOF. Let \mathcal{I} be some set and $p_i: E_i \rightarrow B_i$ be an \mathcal{I} indexed set of maps over corresponding \mathcal{I} indexed spaces, and $p: E \rightarrow B$ be the corresponding products. We claim that:

$$\left(\prod_{i \in \mathcal{I}} p_i \right)^{-1}(b) = \prod_{i \in \mathcal{I}} (p_i^{-1}(b_i)) \quad \text{for all } b = (b_i)_{i \in \mathcal{I}} \in B.$$

We then have a collection of diagrams for each $i \in \mathcal{I}$.

$$\begin{array}{ccc} E_b \subset E & \xrightarrow{\pi_i} & E_i \supset E_{b_i} \\ \downarrow p & & \downarrow p_i \\ b \in B & \xrightarrow{\pi_i} & B_i \ni b_i \end{array}$$

If we trace the path of b through this diagram it is clear that the bottom commutes by the definition of b . Chasing b up the left side we have the fiber $p^{-1}(b)$, and on the right we have the fiber $p_i^{-1}(b_i)$. The previous part says that the restriction of π_i defines a map from the former fiber to the latter. However, the projections map $\prod_{i \in \mathcal{I}} (p_i^{-1}(b_i))$ onto each $p_i^{-1}(b_i)$. \square

A projection $B \times F \rightarrow B$ defines a **trivial fiber space** over B , a definition that makes sense for any space F .

(iii) Show that the fiber of a trivial fiber space $B \times F \rightarrow B$ is isomorphic to F .

PROOF. Given an element $b \in B$, its fiber is $\pi_1^{-1}(b) = \{(b, f) \mid f \in F\}$. Note that if $f = f'$ in F then $(b, f) = (b, f')$ in $B \times F$. Thus $\pi_2|_{\pi_1^{-1}(b)}$ is injective in addition to being surjective, and thus has an inverse map. Further, because the projection is an open map this inverse is also continuous. Thus $\pi_1^{-1}(b)$ is isomorphic to F . \square

- (iv) Characterize the isomorphisms in Top/B between the two trivial fiber spaces (with a priori distinct fibers) over B .

Note that Top/B is a slice category, so an isomorphism in this category is an isomorphism in Top with the additional condition that it commutes with the projections onto B .

Explicitly, we require the following diagram to commute.

$$\begin{array}{ccc}
 B \times F & \xrightleftharpoons{\gamma} & B \times F' \\
 \searrow^{\pi_1} & \delta & \swarrow_{\pi_1} \\
 & B &
 \end{array}$$

Note first that the map γ may be decomposed into $\pi_1\gamma: B \times F \rightarrow B$ and $\pi_2\gamma: B \times F \rightarrow F'$ and the universal property of products guarantees that this decomposition preserves all of the information of γ . Now, one of the identities we can pull from the diagram is that $\pi_1\gamma = \pi_1$. This means we can restrict our consideration to the other projection $\pi_2\gamma$.

Given a homeomorphism $\tilde{\gamma}: F \rightarrow F'$ we may define $\gamma: B \times F \rightarrow B \times F'$ by $(b, f) \mapsto (b, \tilde{\gamma}(f))$. If $\tilde{\gamma}$ is invertible, then it is clear that γ satisfies all of the conditions imposed by the diagram. However, this is too restrictive. What if instead we had a family of maps $\{\gamma_b: F \rightarrow F'\}_{b \in B}$ and defined γ by $(b, f) \mapsto (b, \gamma_b(f))$. In this case γ will satisfy the condition that $\pi_1\gamma = \pi_1$ and if each γ_b is invertible, then γ will be as well, but it is not necessarily the case that γ is continuous, i.e. it might be that γ is not an arrow in our category.

To see how we may impose continuity on γ , recall that a family is in fact a function so we have $\Gamma: B \rightarrow \text{Top}(F, F')$ where $\Gamma(b) = \gamma_b$. Further, we may uncurry this to $\Gamma: B \times F \rightarrow F'$ which is a function for which we have a well defined notion of continuity. Supposing then Γ is continuous in this sense. The universal property of $B \times F'$ then gives us that $\pi_1 \times \Gamma = \gamma$ is continuous and thus a legitimate map for our diagram.

Piecing all of this together, let $\Gamma: B \times F \rightarrow F'$ and $\Delta: B \times F' \rightarrow F$ be continuous maps such that the restrictions are inverses: $\Gamma(b, -) = \Delta(b, -)^{-1}$ for any $b \in B$. Next define $\gamma = \pi_1 \times \Gamma$ so that $\gamma(b, f) = (b, \Gamma(b, f))$ and like wise for δ . Then γ and δ are inverses and satisfy all the conditions imposed by the diagram.

- (v) Prove that the assignment of the set of continuous sections of a fiber space over B defines a functor $\text{Sect}: \text{Top}/B \rightarrow \text{Set}$.

PROOF. We can define Sect by mapping each fiber space p over B to its set of continuous sections, and by mapping each morphism $f: p \rightarrow q$ to a function $f \cdot -: \text{Sect } p \rightarrow \text{Sect } q$ defined by left composition of f . To verify that our proposed function is a map between set of sections let s be a section of p , then $1_B = p \cdot s$. Since $p = q \cdot f$, then $1_B = q \cdot f \cdot s$, showing that $f \cdot s$ is a section of q . To verify that this is indeed a functor, note that the identity morphism on $p: E \rightarrow B$ defined by $1_E: p \rightarrow p$ gets mapped to left composition by 1_E which induces the identity on

Sect p . Take morphism $g \cdot f$. Then $\text{Sect}(g \cdot f) = g \cdot f \cdot - = g \cdot (f \cdot -) = \text{Sect } g \cdot \text{Sect } f$. Thus Sect is a functor \square

- (vi) Consider the non-full subcategory Top_{pb}^2 of fiber spaces in which the morphisms are the pullback squares. Prove that the assignment of the set of continuous sections to a fiber space defines a functor $\text{Sect}: (\text{Top}_{\text{pb}}^2)^{\text{op}} \rightarrow \text{Set}$.

PROOF. We can define Sect by mapping each fiber space p over B to its set of continuous sections and each morphism, $(f, g): p' \rightarrow p$ is a pullback, then (f, g) get mapped to a function $\sigma_{(f,g)}: \text{Sect } p \rightarrow \text{Sect } p'$ defined as follows: each section s of p gets taken to a section s' using the universal property of the pullback (f, g) shown in following diagram:

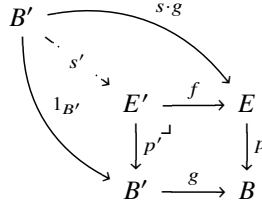

Thus s' is unique for each s confirming that $\sigma_{(f,g)}$ is a function. To verify that Sect is a functor note that the identity morphism on p induces the following commutative diagram:

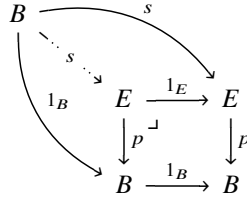

where s is a section.

For morphisms (f', g') and (f, g) such that $(f, g) \cdot (f', g')$ makes sense, if $s \in \text{Sect } p$ with $\sigma_{(f,g)}(s) = s'$ and $\sigma_{(f',g')}(s') = s''$, then $s \cdot g = f \cdot s'$ and $s' \cdot g' = f' \cdot s''$ by the universal property of pullbacks (f', g') and (f, g) . We get that $s \cdot g \cdot g' = f \cdot s' \cdot g' = f \cdot f' \cdot s''$. Since s'' is a section of p'' this allows the following diagram to commute:

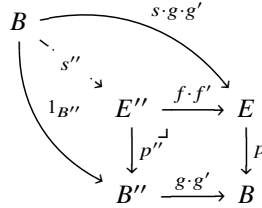

showing that $s'' = \sigma_{(f',g')}(\sigma_{(f,g)}(s)) = \sigma_{(f,g) \cdot (f',g')}(s)$ for all $s \in \text{Sect } p$. Thus, $\sigma_{(f,g) \cdot (f',g')} = \sigma_{(f',g')} \cdot \sigma_{(f,g)}$. This shows that Sect preserves composition. Therefore, Sect is a functor. \square

- (vii) Describe the compatibility between the actions of the “sections” functors just introduced with respect to the map g of fiber spaces p and q over B and their restrictions along $f: B' \rightarrow B$.

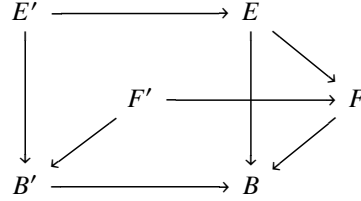

PROOF. Consider the pullbacks

$$\begin{array}{ccc}
 F' & \xrightarrow{\pi_1} & F \\
 q' \downarrow & \lrcorner & \downarrow q \\
 B' & \xrightarrow{f} & B
 \end{array}$$

and

$$\begin{array}{ccc}
 E' & \xrightarrow{\pi_2} & E \\
 p' \downarrow & \lrcorner & \downarrow p \\
 B' & \xrightarrow{f} & B
 \end{array}$$

and a morphism $g: E \rightarrow F$ such that $q \cdot g = p$. Using the universal property of the first pullback, we can derive a new morphism $g': E' \rightarrow F'$ such that

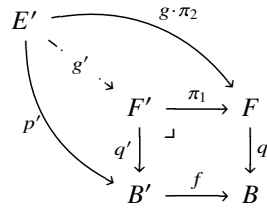

We can treat the triples (g, p, q) and (g', p', q') as morphisms $g: p \rightarrow q$ and $g': p' \rightarrow q'$ in Top/B . We can also treat the two pullback diagrams as morphisms $(\pi_1, f): q' \rightarrow q$ and $(\pi_2, f): p' \rightarrow p$ in Top_{pb}^2 . Applying the functor Sect defined in part 5 to $g: p \rightarrow q$ and $g': p' \rightarrow q'$ we get the functions $g \cdot -: \text{Sect } p \rightarrow \text{Sect } q$ and $g' \cdot -: \text{Sect } p' \rightarrow \text{Sect } q'$. Applying Sect defined in part 6 to the pullback squares we get the functions $\sigma_{(\pi_1, f)}: \text{Sect } q \rightarrow \text{Sect } q'$ and $\sigma_{(\pi_2, f)}: \text{Sect } p \rightarrow \text{Sect } p'$. To show that two definitions of Sect are compatible, we will show that the following diagram commutes:

$$\begin{array}{ccc}
 \text{Sect } p & \xrightarrow{g \cdot -} & \text{Sect } q \\
 \sigma_{(\pi_2, f)} \downarrow & & \downarrow \sigma_{(\pi_1, f)} \\
 \text{Sect } p' & \xrightarrow{g' \cdot -} & \text{Sect } q'
 \end{array}$$

which should be the result of applying a functor Sect overloaded with the definitions from part 5 and 6 to the following diagram:

$$\begin{array}{ccc}
 E' & \xrightarrow{\pi_2} & E \\
 \downarrow g' \lrcorner & & \downarrow g \\
 F' & \xrightarrow{\pi_1} & F \\
 \downarrow q' \lrcorner & & \downarrow q \\
 B' & \xrightarrow{f} & B
 \end{array}
 \begin{array}{l}
 p' \\
 \left. \begin{array}{c} \\ \\ \\ \end{array} \right\} \\
 p
 \end{array}$$

which is the combination of the two pullbacks with the morphisms g and g' included. Let $s \in \text{Sect } p$, then $g \cdot s \in \text{Sect } q$ and $\sigma_{(\pi_2, f)}(s) = s' \in \text{Sect } p'$. To show that $g' \cdot s' = \sigma_{(\pi_1, f)}(g \cdot s)$ we will use the universal property of the second pullback defined at the beginning of the proof. This gives us $\pi_2 \cdot s' = s \cdot f$. By extension, $g \cdot \pi_2 \cdot s' = g \cdot s \cdot f$. By the diagram above, this gives us that $\pi_1 \cdot g' \cdot s' = g \cdot s \cdot f$. Furthermore $q' \cdot g' \cdot s' = p' \cdot s' = 1_{B'}$. This allows the following diagram to commute:

$$\begin{array}{ccc}
 B' & \xrightarrow{g \cdot s \cdot f} & F \\
 \downarrow 1_{B'} & \searrow g' \cdot s' & \downarrow q \\
 & F' & \xrightarrow{\pi_1} & F \\
 & \downarrow q' & \lrcorner & \downarrow q \\
 & B' & \xrightarrow{f} & B
 \end{array}$$

This confirms that $g' \cdot s' = \sigma_{(\pi_1, f)}(g \cdot s)$ and that the diagram formed by the Sect functor commutes. This shows that the definitions of Sect in 5 and 6 are compatible in the sense that Sect overloaded with both definitions, preserves commutativity of diagrams formed by morphisms of Top/B and Top_{pb}^2 \square

3.6 Functoriality of limits and colimits

EXERCISE 3.6.i. In a category \mathbf{C} with pullbacks, prove that the mapping $\lim : \mathbf{C}^{\bullet \rightarrow \bullet \leftarrow \bullet} \rightarrow \mathbf{C}$ defined in Proposition 3.6.1 is functorial.

Proof. First, we will define the category $\mathbf{C}^{\bullet \rightarrow \bullet \leftarrow \bullet}$ and the mapping $\lim : \mathbf{C}^{\bullet \rightarrow \bullet \leftarrow \bullet} \rightarrow \mathbf{C}$ more clearly. The following diagram describes an object $x \in \mathbf{C}^{\bullet \rightarrow \bullet \leftarrow \bullet}$:

$$x_1 \xrightarrow{x_\alpha} x_2 \xleftarrow{x_\beta} x_3$$

where x_1, x_2, x_3 are objects in \mathbf{C} and $x_\alpha : x_1 \rightarrow x_2, x_\beta : x_3 \rightarrow x_2$ are morphisms in \mathbf{C} . The next commutative diagram defines a morphism $f : x \rightarrow y \in \mathbf{C}^{\bullet \rightarrow \bullet \leftarrow \bullet}$:

$$\begin{array}{ccccc} x_1 & \xrightarrow{x_\alpha} & x_2 & \xleftarrow{x_\beta} & x_3 \\ f_1 \downarrow & & f_2 \downarrow & & f_3 \downarrow \\ y_1 & \xrightarrow{y_\alpha} & y_2 & \xleftarrow{y_\beta} & y_3 \end{array}$$

Finally, the following diagram defines the mapping $\lim : \mathbf{C}^{\bullet \rightarrow \bullet \leftarrow \bullet} \rightarrow \mathbf{C}$ described in Proposition 3.6.1 by its actions on objects and morphisms:

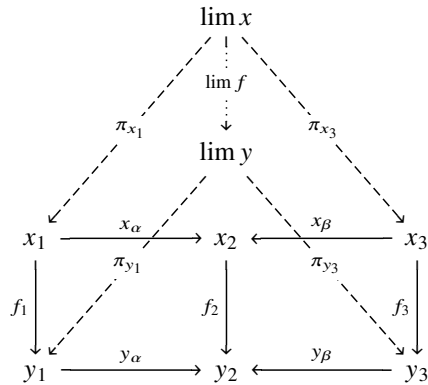

where π_{x_1}, π_{x_3} and π_{y_1}, π_{y_3} are the legs of pullbacks from x and y , respectively. Suppose f is the identity of x, I_x . Then we have

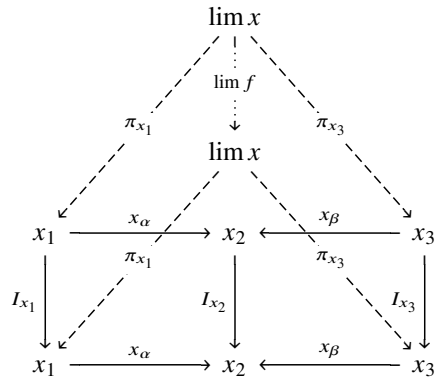

or more succinctly,

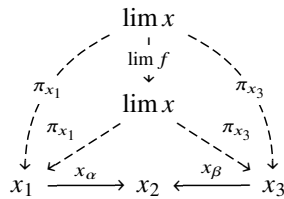

So in this case, $(\pi_{x_1})(\lim f) = \pi_{x_1}$, which means $\lim I_x = I_{\lim x}$. So \lim takes identities to identities.

Let $f : x \rightarrow y, g : y \rightarrow z, gf : x \rightarrow z$ be composable morphisms in $\mathbf{C}^{\bullet \rightarrow \bullet \leftarrow \bullet}$. This composition is described by the following diagram:

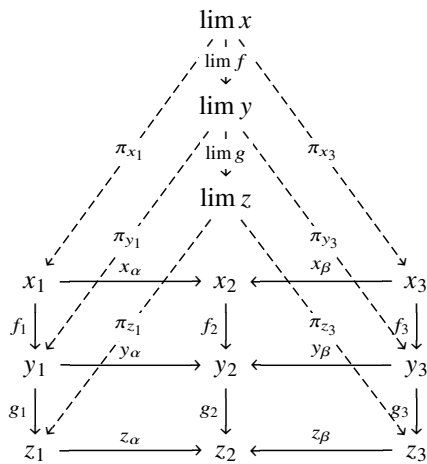

And by composing the $\lim g$ and $\lim f$ arrows in this diagram we can obtain:

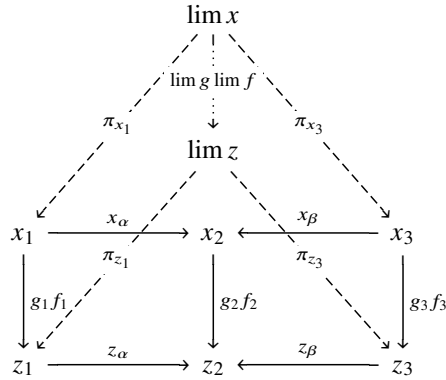

and since $\lim z$ is a limit, $\lim g \lim f$ must be the unique morphism $\lim x \rightarrow \lim z$ such that this diagram composes (for a given $\pi_{x_1}, \pi_{x_3}, \pi_{z_1}, \pi_{z_3}$.) But the following diagram describes $\lim g f$:

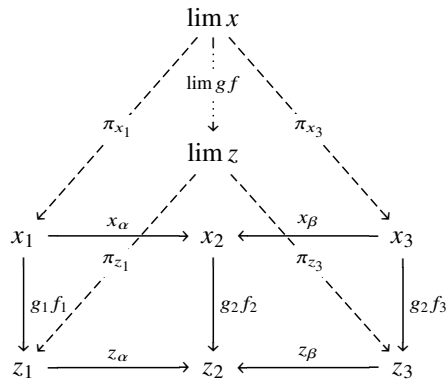

and again, since $\lim z$ is a limit, $\lim g f$ must be the unique morphism $\lim x \rightarrow \lim z$ such that this diagram composes (for a given $\pi_{x_1}, \pi_{x_3}, \pi_{z_1}, \pi_{z_3}$.) But $\pi_{x_1}, \pi_{x_3}, \pi_{z_1}, \pi_{z_3}$ are the same in both diagrams, so both 'unique morphisms' must be the same morphism — which is to say, $\lim g f = \lim g \lim f$.

Finally, we were given that \mathbf{C} has pullbacks, so there exist a $\lim x, \lim y, \lim f$ for all $x, y \in \text{ob } \mathbf{C}^{\bullet \rightarrow \bullet \leftarrow \bullet}$; $f : x \rightarrow y \in \text{mor } \mathbf{C}^{\bullet \rightarrow \bullet \leftarrow \bullet}$. So \lim is well-defined.

In conclusion, the mapping $\lim : \mathbf{C}^{\bullet \rightarrow \bullet \leftarrow \bullet} \rightarrow \mathbf{C}$ fulfills all the necessary conditions to be functorial, so it is a functor. \square

EXERCISE 3.6.ii. Prove lemma 3.6.6. For any triple of objects X, Y, Z in a category with binary products, there is a unique natural isomorphism $X \times (Y \times Z) \cong (X \times Y) \times Z$ commuting with the projections to X, Y , and Z .

PROOF. Take the product of the three objects $X, Y, Z, X \times Y \times Z$, with the projections $\pi_X : X \times Y \times Z \rightarrow X, \pi_Y : X \times Y \times Z \rightarrow Y, \pi_Z : X \times Y \times Z \rightarrow Z$. For an object W such that for morphisms $f : W \rightarrow X, g : W \rightarrow Y$, and $h : W \rightarrow Z$, there is a unique morphism $k : W \rightarrow X \times Y \times Z$, with $f = \pi_X k, g = \pi_Y k$, and $h = \pi_Z k$.

Now, for the product $X \times (Y \times Z)$, with the projections $\gamma_Y : Y \times Z \rightarrow Y$ and $\gamma_Z : Y \times Z \rightarrow Z$, there is a unique morphism $k : W \rightarrow Y \times Z$ such that $\gamma_Y k = g$, and $\gamma_Z k = h$. Also, for the projections $\sigma_X : X \times (Y \times Z) \rightarrow X$, and $\sigma_{Y \times Z} : X \times (Y \times Z) \rightarrow Y \times Z$, there is a unique morphism $l : W \rightarrow X \times (Y \times Z)$ such that $\sigma_X l = f$ and $\sigma_{Y \times Z} l = k$. Then $f = \sigma_X l, g = \gamma_Y \sigma_{Y \times Z} l$, and $h = \gamma_Z \sigma_{Y \times Z} l$. So there exists a morphism l with domain W , that factors through $X \times (Y \times Z)$, through the composite projections to each object X, Y , and Z .

Now to show the uniqueness of l , let m be another such morphism as l . Then $f = \sigma_X m, g = \gamma_Y \sigma_{Y \times Z} m$, and $h = \gamma_Z \sigma_{Y \times Z} m$. So from the uniqueness of k , since $g = \gamma_Y (\sigma_{Y \times Z} m)$, and $h = \gamma_Z (\sigma_{Y \times Z} m)$, then $\sigma_{Y \times Z} m = k$, and thus $m = l$. So l is the unique morphism factoring through $X \times (Y \times Z)$. From the universal property of products, then there is a unique isomorphism $X \times (Y \times Z) \cong X \times Y \times Z$.

Likewise, a similar argument shows that there is a unique isomorphism from $(X \times Y) \times Z$ to $X \times Y \times Z$, and so $X \times (Y \times Z) \cong (X \times Y) \times Z$.

3.7 Size matters

EXERCISE 3.7.i. Complete the proof of Lemma 3.7.1 by showing that an initial object defines a limit of the identity functor $1_{\mathbf{C}} : \mathbf{C} \rightarrow \mathbf{C}$.

PROOF. Call the initial object we are considering i . We are looking for a universal cone, $\alpha : i \Rightarrow 1_{\mathbf{C}}$. We note that i has unique morphisms to arbitrary elements c, d in \mathbf{C} as it is initial. Let $f : i \rightarrow c, g : i \rightarrow d$ be the unique morphisms, and let $h : c \rightarrow d$ be arbitrary. We note then that $g = hf$, as there is only one morphism from i to d in \mathbf{C} . This establishes that we have a cone over $1_{\mathbf{C}}$.

Now we must show it is universal. We consider another object n as the apex that forms a valid cone $\beta : n \Rightarrow 1_{\mathbf{C}}$. Because i is initial, we know there exists a unique morphism $h : i \rightarrow n$. Considering h as a natural transformation between constant functors, we now must show that $\alpha = \beta \cdot h$ (vertical composition), noting that both sides are $i \Rightarrow 1_{\mathbf{C}}$. We look at any leg t of the cone. We see that $(\beta \cdot h)_t = \beta_t * h$ is a morphism with domain i that shares a codomain with α_t , and thus must be the same as α_t because i is initial and morphisms from i are unique. Thus, as all of the legs are the same, α must equal $\beta \cdot h$, which guarantees that every cone β factors through α .

3.8 Interactions between limits and colimits

EXAMPLE 3.2.16. An **idempotent** is an endomorphism $e: A \rightarrow A$ of some object so that $e \cdot e = e$. The limit of an idempotent in **Set** is the set of cones with summit 1, i.e., the set of $a \in A$ so that $ea = a$. This is the set of **fixed points** for the idempotent e , often denoted by A^e .

Alternatively, applying Theorem 3.2.13 in the simplified form in Exercise 3.2.ii, the limit A^e is constructed as the equalizer

$$A^e \xrightarrow{s} A \xrightleftharpoons[e]{1} A$$

The universal property of the equalizer implies that e factors through s along a unique map r .

$$\begin{array}{ccc} A & & \\ \downarrow r & \searrow e & \\ A^e & \xrightarrow{s} & A \xrightleftharpoons[e]{1} A \end{array}$$

The factorization $e = sr$ is said to **split** the idempotent. Now $srs = es = s$ implies that rs and 1_{A^e} both define factorizations of the diagram

$$\begin{array}{ccc} A^e & & \\ \downarrow rs & \searrow s & \\ A^e & \xrightarrow{s} & A \xrightleftharpoons[e]{1} A \end{array}$$

Uniqueness implies $rs = 1_{A^e}$ so A^e is a retract of A . Conversely, any retract diagram

$$B \xrightarrow{s} A \xrightarrow{r} B \quad rs = 1_B$$

gives rise to an idempotent sr on A , which is split by B .

EXERCISE 3.8.i. Dualize the construction of Example 3.2.16 to express the splitting of an idempotent as a coequalizer. Explain why these colimits (or limits) are preserved by any functor and conclude that splittings of idempotents commute with both limits and colimits of any shape.

PROOF. As in the example, the colimit A_e can be constructed as a coequalizer:

$$A \xrightleftharpoons[e]{1} A \xrightarrow{s} A_e$$

And the universal property implies that e factors through rs where r is unique:

$$\begin{array}{ccc} A \xrightleftharpoons[e]{1} A & \xrightarrow{s} & A_e \\ & \searrow e & \downarrow r \\ & & A \end{array}$$

where s has become an epimorphism, and the factorization $e = rs$ splits the idempotent (note the change in order of the factorization: rs , from the original category's sr). Then we have $sr s = se = s$ implies that sr and 1_{A_e} are factorizations of

$$\begin{array}{ccc}
 A & \xrightarrow[e]{1} & A & \xrightarrow{s} & A_e \\
 & & & \searrow & \parallel \\
 & & & & sr \parallel 1_{A_e} \\
 & & & \searrow & \downarrow \\
 & & & & A_e
 \end{array}$$

And uniqueness implies that $sr = 1_{A_e}$, so A_e is a retract of A . Conversely, any retract of the form

$$B \xrightarrow{r} A \xrightarrow{s} B$$

gives an idempotent sr on A , which is split by B . (This gives a construction of Example 1.2.9 and its dual, of split monomorphisms and split epimorphisms.)

To see that these limits and colimits are preserved by any functor F , note that we have for any idempotent $e: A \rightarrow A$, that $Fe \circ Fe = F(e \circ e) = Fe$. That is, functors take idempotents to idempotents. Then, since all splittings of idempotents can be expressed as an equalizer (with a limit A^e) or a coequalizer (with a colimit A_e), it must be that any functor preserves these limits (or colimits).

Finally, since these splittings of idempotents can be expressed as both limits and colimits, by Theorem 3.8.1 (that limits commute with limits) and its dual (for colimits), they commute with limits and colimits of any shape. \square

EXERCISE 3.8.ii. Show that if G and H are groups whose orders are coprime, BG -indexed limits commute with BH -indexed colimits in \mathbf{Set} . *Note: The proof strategy is based on that of Lemma 3.1 in the cited paper*

PROOF. We know that by definition, BG -indexed limits are the sets $X^G = \{x \in X \mid gx = x \text{ for all } g \in G\}$, and that BH -indexed colimits in \mathbf{Set} are the sets of orbits of the group action induced by H . We must show that the fixed "points" under G in the set of orbits of H are equivalent to the orbits of H that consist of fixed points under G . We also know that $\lim_G \text{colim}_H F$ and $\text{colim}_H \lim_G F$ are defined for a functor $F: BG \times BH \rightarrow \mathbf{Set}$. So we can interpret gx as $(g, 1_H)x$ and hx as $(1_G, h)x$ and see that the actions of G and H commute. First, consider an orbit in X that is fixed under the action of G . This means that for all $x \in X$ and $g \in G$, $gx = hx$ for some $h \in H$. Because $g = (g, 1_H)$ and $h = (1_G, H)$ commute, we have that $g^i x = h^i x$. We see that the set of $g^i x$ forms an orbit of the cyclic group generated by g acting on X and similarly for the set of element $h^i x$. By this, we know that the smallest $n > 0$ such that $g^n a = a$ divides $|g|$ and that the smallest $m > 0$ such that $h^m a = a$ divides $|h|$ and that $n = m$ by the equality $g^i x = h^i x$ that we stated before. Since $|G|$ and $|H|$ are coprime and therefore so are $|g|$ and $|h|$, $n = 1$ and $gx = x$. This holds for all $g \in G$. So every x in an orbit under the action of H that is fixed by the action of G is a fixed point of G and we have equality between the fixed orbits of H under G ($\lim_G \text{colim}_H F$) and the orbits under H of the fixed points of G ($\text{colim}_H \lim_G F$). \square

Reference:

M. Bjerrum, P. Johnstone, T. Leinster, W.F. Sawin, Notes on Commutation of Limits and Colimits, *Theory and Applications of Categories*, 30, 527-532 (2015).